

Since 1978

**AUTO  
KRAFTERS**



'70-'77 Maverick  
'71-'77 Comet

# Maverick

**Parts and Accessories**

Shop Online!  
[www.autokrafters.com](http://www.autokrafters.com)



- Weatherstrip
- Interior
- Trunk / Exterior
- Engine
- Transmission / Clutch
- Suspension / Steering
- Brake
- Hardware
- Decals
- Books / Videos
- Accessories / Chemicals

**2021**

# ORDERING INFORMATION

## Order by Phone

It's fast and convenient! For best service have all catalog and credit card information ready, then call:

**TOLL-FREE ORDER LINE 1-800-228-7346\***  
**FAX NUMBER 1-540-901-2908**  
**LOCAL NUMBER 1-540-896-5910**

A \$20 MINIMUM IS REQUIRED FOR ORDERS PLACED OVER THE PHONE. Mastercard, VISA, Discover and American Express are welcome. C.O.D. shipments are not available for any items.

## Mail Orders

Fill out the order blank in the back of this catalog. For fastest delivery, send a money order or cashier's check. **Personal checks are accepted but will delay the order 7 days while the check clears the bank.** Mastercard, VISA, Discover and American Express are welcome. **A \$20 MINIMUM IS REQUIRED FOR ORDERS PLACED THROUGH THE MAIL.** Be sure to include card number, expiration date, billing address, and signature of cardholder.

## Fax Orders

Accepted 24 hours daily. Mastercard, VISA, Discover and American Express. **A \$20.00 MINIMUM IS REQUIRED FOR ORDERS PLACED OVER THE FAX.** Fax number is 540-901-2908.

## Warranty / Exchanges

All parts are guaranteed. **Please inspect the shipment as soon as you receive it.** If you have a problem with any purchase, please call one of our associates at 800-228-7346\*. Many times, application problems can be quickly handled by phone, saving needless shipping expense. Should you find it necessary to return anything, a copy of our return procedures is packed with your invoice. **All claims for shortages must be made within 48 hours. No shortage claims will be accepted after 48 hours. To better facilitate our handling of returned items, please call and obtain a return authorization number. All returns must be sent prepaid. C.O.D. returns will be refused. Returns older than 30 days are subject to a restock fee. Absolutely no returns after 120 days from date of purchase regardless of reason unless covered by an extended warranty.** We reserve the right to charge a restocking fee on certain items. Special orders are also subject to a restock fee. Auto Krafters, Inc.'s liability is limited to the replacement of the product or refund of the purchase price. Installation labor costs or shipping charges are not refunded. Electrical parts are non-returnable once installed. We will replace defective units only. **Our associates are available from 9:00-5:00 Monday-Friday ET.**

## Warehouse Location

Auto Krafters, Inc.'s office and warehouse are located in Broadway, Va., off Interstate 81 exit 257, 129 Hartz Blvd. + Broadway, VA 22815. Our local phone number is 540-896-5910. **Sorry no personal checks accepted for showroom purchases without prior authorization.**

## Store Hours (Eastern time zone)

MONDAY-FRIDAY ..... 9:00 AM-5:00 PM  
SATURDAY ..... 9:00 AM-NOON  
SUNDAY ..... CLOSED

## Phone Hours (Eastern time zone)

MONDAY-FRIDAY ..... 9:00 AM-5:00 PM  
SATURDAY ..... 9:00 AM-NOON  
SUNDAY ..... CLOSED

## Shipping Charges

In the continental United States, there is a **minimum shipping charge of \$14.95.** Most orders are shipped via UPS or FedEx. Please furnish a complete street address as UPS cannot deliver to a post office box number. **We reserve the right to ship extra heavy or oversized shipments freight collect.** Hoods, fenders and quarter panels fall in this category. If you have prepaid the shipping and the order has to be shipped freight collect, we will refund your prepaid shipping. If you have any question, please call us at 800-228-7346\* for assistance. **Please check all truck shipments for damage before signing the bill of lading. Once truck shipments are signed for, no claims can be made for damage.** Some parts require additional handling charges. Fragile items, such as mouldings, will be shipped in PVC tubes and will incur a \$15 handling fee. All oversized items will incur a \$10 boxing fee and / or crate charges where applicable. Please inquire about additional handling charges when ordering.

Alaska, Hawaii, Puerto Rico and Canadian orders should add 20% estimated shipping and handling with a minimum of \$20.00. Other foreign countries should add 35% with a minimum of \$20.00. Any excess will be refunded. Canadian customers are responsible for all customs brokerage fees and duties.

## Customer Satisfaction

Our goal is customer satisfaction and we strive to sell the highest quality parts at competitive prices. If you encounter a problem with your order, contact us immediately so that we may resolve the problem. We want your repeat business and the business of your friends and neighbors. Most orders are processed and shipped within 24 hours of receipt. If we should need to back order any items, they will be shipped as soon as possible unless you notify us otherwise. If you require your parts delivered by a specific date, please advise us when placing your order and we will do our best to accommodate your needs.

## Back Ordered Items

Due to the difficulty of keeping some items in stock, an item you order may be put on back order for later delivery. Most back ordered items can be shipped in 21 days. If you do not receive your back ordered items within the time stated on your notification letter, please call us at 1-800-228-7346\* for a revised delivery date.

## Origin of Parts

We sell both Genuine Ford and quality reproduction parts acquired from many sources, both domestic and foreign. We will be happy to give you the country of origin of all our parts, if known. All Ford Trademark parts sold (such as emblems, etc.) are licensed by Ford Motor Company\*. **The majority of the parts in this catalog are made in the USA, are reproductions of originals and are NOT Genuine Ford.** Auto Krafters is proud to offer reproduction parts and accessories from such manufacturers as Dennis Carpenter®, Auto Custom Carpet®, Jim Osborn Reproductions®, Drake Automotive Group® and many others.

**NOTE:** We are not responsible for typographical errors. Prices are subject to change without notification.

**NOTE:** Illustrations are typical and may not be representative of the part you are ordering.

Secure online ordering @ our web site  
<http://www.autokrafters.com>

## COVER PHOTO

1973 Comet 2-door (modified) courtesy of  
Mark Duplissie of Emmett, Idaho

\* US customers only. Outside the US, please dial 540-896-5910

Copyright © 2021 Auto Krafters, Inc. All rights reserved. Printed in the United States of America. No part of this publication may be reproduced including drawings, photographs or text without the prior written permission of Auto Krafters, Inc. All statements and recommendations contained herein are based on information we believe to be reliable, but the accuracy thereof is not guaranteed

A/C.....	Components .....	5, 13, 45–46, 61	Dimmer Switch .. Cap .....	18	Glass .....	39	
	Hardware Kit .....	83	Distributor .....	58	Glossary .....	98	
Accelerator .....	Cable .....	50	..... Cap & Rotor .....	60	Glove Box.....	Door Bumper .....	5, 14
	Pedal Hardware .....	81	..... Hold-Down Clamp .....	60, 84	..... Liner .....	33	
Air Cleaner.....		52–53	..... Vacuum Control .....	49	Grille .....	Emblem.....	14
	Adapter .....	53	Dome Lamp.....	24	..... Lamp Parts .....	3, 31	
	Heat Shroud; Knob .....	54	..... Lens .....	24	Harmonic Balancer Related .....	48	
	Wing Nut .....	54, 84	..... Switch .....	26	Headers & Related .....	56–57, 85	
Air Filter .....		53	Door.....	9	Headlamp .....	Adjust Kit; Spring .....	29, 81
Alternator & Related .....		4, 44–45, 84	..... Board .....	5, 23	..... Area Hardware .....	29, 81	
Antennas & Related.....		30	..... Bumper .....	5, 23	..... Bucket .....	29	
Arm Rest.....	Base; Pads .....	9	..... Handle (Exterior).....	31	..... Bulb, Ring & Related .....	29	
	Clips & Screws .....	10, 80	..... Handle (Interior).....	23	..... Dimmer Switch .....	25	
Axle Bumper .....		5, 74	..... Handle Pad .....	4, 30	..... Dimmer Switch Cap.....	18	
Back Glass Weatherstrip .....		3	..... Hinge Hardware .....	23, 80	..... Socket & Wiring .....	29	
Back-up Lamp Switch.....		26	..... Latch & Related .....	23, 80	..... Switch .....	25	
Ball Joint .....		67	..... Latch-Area Repair.....	23	Headliner .....	Retainers .....	12, 81
Barrel Clips .....		33, 82	..... Lock Cyl. & Related ...	4, 24, 31, 81	..... Blower Motor.....	13	
Battery Related.....		44–45, 84	..... Lock Kit (Power).....	24	..... Box Clip .....	13, 81	
Bellhousing Separator Plate .....		64	..... Lock Knob, Grommet .....	23	..... Control Valve .....	13, 43	
Beltline Weatherstrip .....		3	..... Lock Set .....	24, 31	..... Core .....	13	
Body Bolt .....		37, 82	..... Panels .....	8–9	..... Hose .....	43	
Books / Videos.....		89–91	..... Step Plate & Related .....	10, 80	..... Hose Clamp .....	41, 43, 84	
Brake .....	Adjustment Hole Covers .....	5, 77	..... Striker Plate & Related .....	23, 81	Heat Shield .....		10, 27
	Booster Related .....	75	..... Water Shields.....	9	Hood .....		35
	Calipers .....	77	..... Weatherstrip .....	3	..... Bumper .....	5, 29	
	Conversion Kit .....	79	..... Window Regulator .....	22	..... -Cowl Seal .....	3	
	Distribution Valve .....	75	Drag Link .....	70	..... Hinges .....	28	
	Drum .....	76	Drive Shaft Yokes .....	64	..... Insulation .....	29	
	Drum Upgrade Kit .....	79	EFI Throttle Body Conversion Kits .....	49	..... Latch .....	28	
	Hardware .....	77, 86	Emblems .....	33	..... Moulding .....	32	
	Hose Clips .....	76, 86	Emergency Flasher Switch Relay.....	26	..... Pin Kit .....	28	
	Hoses .....	76	Engine .....	56	..... Prop Rod .....	28	
	Lamp Switch .....	26, 75, 79	..... Gasket Set .....	56	..... Scoop.....	36	
	Master Cylinder & Related .....	75	..... Gauge Feed .....	61	Horn.....		61
	Pads .....	77	..... Hardware .....	83–85	..... Blow Switch Covers .....	17	
	Pedal Related Parts.....	18, 79	..... Hose Clamp Kit .....	41, 84	..... Blow Switch Trim Plate .....	17	
	Plate Mounting Bolts .....	77, 86	..... Mount .....	55	..... Pads & Inserts .....	17	
	Press. Differ. Warn. Switch .....	75	..... Section .....	40–61	..... Relay .....	61	
	Proportioning Valve.....	75	..... Swap Mount Kit.....	55	..... Switch .....	17, 26	
	Rotor .....	77	..... & Trunk Lamp Kit .....	28, 61	Hub Cap .....		39
	Section .....	75–79	..... Volt. Reg. & Related .....	44	HumpHuggers .....		20
	Self-Adjuster Repair Kits.....	77, 86	..... Wiring / Electrical .....	58–61	Idle Arm & Related .....		70
	Shoe Hardware Kits .....	77, 86	Exhaust.....	56–57, 85	Ignition .....	Boxes.....	59
	Shoes .....	77	..... Headers & Rel .....	56–57, 85	..... Coil .....	59, 60	
	Speed Bleeders .....	77	..... Manifold & Related .....	57	..... Coil Bracket .....	60	
Bumper .....	Bolt Kit .....	35, 82	..... Port Divider .....	57	..... Cylinder & Key .....	24	
	Brackets; Braces .....	35	..... Tips .....	56	..... Lock Set .....	24, 31	
	New .....	35	Exterior .....	33, 34–35, 88	..... Switch, Bezel .....	25	
	Stone Deflector .....	35	..... Hardware .....	36–37, 81–82	Ignitor Ignition System .....	58–59	
Bumpers, Plugs & Grommets .....		5	..... Section .....	28–39	Instr. Cluster .....	Circuit Board .....	26
Cage Nuts .....		82	..... Blade .....	42	..... Lens .....	15	
Carburetor & Related.....		48–49	..... Shroud .....	41	..... Light Bulb Socket .....	15	
Carpets .....		11	..... Spacer & Related .....	42, 85	..... Voltage Regulator .....	26	
Center Links .....		70	Fast Idle Cam Lever .....	49	Intake Manifold & Related .....		50
Chemicals & Adhesives .....		93–97	Fender .....	36, 82	Interior .....	Hardware .....	80–81
Clothing .....		92	..... Emblem .....	33	..... Section .....	6–26	
Clutch .....	Disc.....	66	..... Sheet Metal.....	36	..... Wiring / Electrical .....	25–26	
	Equalizer Parts .....	65	Firewall .....	13, 81	Key Blank .....		24
	Fork .....	65	..... Insulation Retainer .....	13, 81	Kick Panels.....		10
	Hardware .....	85	..... Insulator / Pad.....	13	Leaf Spring & Related .....		74, 86
	Kit .....	66	Flasher Switch .....	26	License Plate Lamp Parts.....		4, 32
	Lever Dust Shield .....	4, 66	Flexplate & Related .....	63–64, 85	Lift Kit .....		74
	Lever Pivot Bracket.....	66	Floor .....	11	Lug Nut.....		37, 38, 39
	Pedal Arm Mount Bushing .....	64	..... Covering .....	11	Lug Wrench .....		39, 93
	Pedal Pad & Trim .....	18, 64	..... Mat .....	11	Marker Lamp Related .....		4, 31–32, 81
	Pedal Rod-Firewall Seal .....	65	..... Pan Plug .....	5	Master Cylinder & Related.....		75
	Pedal Rod Seal.....	4	..... Shifter Boot Bezel .....	21	Mirror .....	Bezel Nut (Sport) .....	22
	Pedal Suppt. Repair Kits .....	64–65	Flywheel & Related.....	63, 85	..... Exterior & Related.....		4, 30
	Pilot Bearing .....	66	Frame Mount .....	55	..... Interior & Related .....		30
	Pressure Plate .....	66	Freeze Plug Kit .....	41	Moulding .....		20
	Pressure Plate Bolts .....	66, 85	Fuel / Gas .....	52	..... Clip .....		82–83
	Release Lever .....	65	..... Cap .....	52	..... Removal Tool .....		82, 93
	Release Lever Rod .....	65	..... Fill Pipe-Trunk Floor Seal .	4, 28, 52	..... Screws .....		82, 83
	Section .....	64–66	..... Filler Pipe .....	52	Muffler.....		56
	Throwout Bearing .....	66	..... Filler Pipe-Tank Hose .....	4, 52	Neutral Safety Switch .....		61
Coat Hook Related .....		25, 81	..... Filter .....	50	Oil .....	Dipstick .....	47
Coil Spring & Related .....		68	..... Hose Clamp .....	41, 84	..... Filler Cap .....		47–48
Console (Removable).....		20	..... Line-Fender Apron Grommet .	5, 51	..... Filler Cap Adapter .....		48
Control Arm & Related .....		67	..... Lines & Hoses.....	51	..... Filter .....		47
Control Valve .....	New & Related .....	71–72	..... Pump .....	50	..... Gauge .....		13–14
	Rebuilds .....	70	..... Pump Block-off Plate .....	51	..... Pan & Related.....		46–47, 85
Dash Area Components .....		14–15	..... Sender & Related .....	51, 85	..... Pressure Sender.....		47, 61
Decals .....		87–88	..... Tank .....	51–52	..... Pump Screen Assembly.....		47
Dimmer Switch .....		25	..... Tank-Filler Pipe Seal .....	4, 52			
			..... Tank Strap & Related .....	52			
			..... Vapor Separator Vent .....	51			
			..... Vapor Valve, Grommet .....	51			
			Gauge.....	13–14			
			..... Aftermarket .....	13–14			
			..... Feeds .....	61			
			..... Mounting Stud Insulator.....	14			

**NOTE: We use Ford-type part numbers in our catalogs for reference only. Most parts listed are quality reproductions of the originals and are NOT Genuine Ford. Those part numbers marked with a  also fit corresponding '71 – '77 Comet models.**

Package Tray.....	25	Spare Tire.....	Cover.....	28	Trunk.....	Divider Insulation.....	28						
Parking Brake Related.....	18, 78, 86	Mount.....	36	Emblem.....	33	& Engine Lamp Kit.....	28, 61						
Parking Lamp Parts.....	3, 31	Mounting Nut.....	28, 81	Floor Plug.....	5, 28	Hardware.....	81						
PCV Related.....	5, 55	Wire Separator.....	60	Latch.....	28	Latch Release (Remote).....	24, 28						
PerTronix.....	58-59	Wires.....	59, 60	Latch Striker Plate.....	28	Lock & Related.....	4, 28						
Pilot Bearing.....	66	Speedometer.....	Cable.....	15	Mat.....	27	Section.....	27-28					
Pitman Arm.....	70	Cable Clip.....	15, 62	Gear & Related.....	15, 62-63	Weatherstrip.....	3	Wiring Related.....	30				
..... Related.....	70, 86	Head Gasket.....	15	Spindle Lock Nut Kit.....	78, 86	Tube Nuts.....	33, 82	Turn Signal.....	Cam Repair Kit.....	26			
Points Eliminator Kit.....	60	Spoiler.....	35	Starter.....	46	..... Lever.....	17	..... Switch.....	25	U-bolts.....	74, 86		
Power Cylinder Related.....	71	Starter Solenoid.....	43-44	Steering.....	Col. Bearing & Related.....	18, 73	.....	U-Joint Repair Kit.....	64, 85	Underhood & Trunk Hardware Kit.....	83		
Power Steer.....	Control Valve & Related.....	71-72	..... Col.-Firewall Seal.....	4	..... Col. Lock Actuator.....	24	.....	U-Nuts.....	37, 82	Valance.....	Front.....	35	
..... Conversion Kits.....	73	..... Coupler Repair Kit.....	71	.....	..... Gear Box & Related.....	71	.....	Valve Cover & Related.....	54-55, 85	Volt. Regulator... Engine & Related.....	44	.....	36
..... Hoses.....	72-73	..... Gear Wheel & Related.....	15-17, 81	.....	.....	10, 80	.....	.....	54-55, 85	..... Instrument Cluster.....	26	.....	42
..... Pump & Related.....	71	Step Plate & Related.....	10, 80	.....	.....	35	.....	.....	54-55, 85	..... Pump, Pulley.....	42	.....	9
..... Rebuilds.....	70, 71	Stone Deflector.....	35	.....	.....	86	.....	.....	54-55, 85	..... Shield.....	9	.....	13-14
Qtr. Panel.....	Drain Valve.....	5, 36	Striker Plate & Related.....	23, 81	.....	67-70	.....	.....	54-55, 85	..... Temperature Gauge.....	13-14	.....	61
..... Extension Seals.....	3	Stripe Kits.....	33-34	.....	.....	74	.....	.....	54-55, 85	..... Temperature Sender.....	61	.....	3
..... Sheet Metal.....	36	Strut Rod & Related.....	68, 86	.....	.....	68	.....	.....	54-55, 85	Weatherstrip... Kit.....	3	.....	3-5
Qtr. Window.....	Moulding.....	32	Sunvisor & Related.....	12	.....	68-69	.....	.....	54-55, 85	..... Section.....	3-5	.....	37-39
..... Seals.....	3	Suspension.....	Bumper (Front).....	5, 67	.....	14, 25	.....	.....	54-55, 85	.....	37-39	.....	77-78
Radiator.....	40	..... Crossmember.....	69	.....	.....	86	.....	.....	54-55, 85	.....	37-39	.....	39
..... Cap.....	40-41	..... Hardware.....	86	.....	.....	67-70	.....	.....	54-55, 85	.....	37-39	.....	39
..... Drain Cock.....	41	..... Parts (Front).....	67-70	.....	.....	74	.....	.....	54-55, 85	.....	37-39	.....	76
..... Hose.....	41	..... Parts (Rear).....	74	.....	.....	68	.....	.....	54-55, 85	.....	37-39	.....	39
..... Hose Clamp.....	41, 84	Sway Bar.....	End Link Kits.....	68	.....	68-69	.....	.....	54-55, 85	.....	37-39	.....	39
..... Overflow Hose.....	41	..... Mounts.....	68-69	.....	.....	14, 25	.....	.....	54-55, 85	.....	37-39	.....	39
..... Suppt.-Hood Bumper.....	5, 41	Tachometer & Related.....	14, 25	.....	.....	4, 32, 80	.....	.....	54-55, 85	.....	37-39	.....	39
..... Suppt.-Hood Seal.....	3	Taillight Related.....	4, 32, 80	.....	.....	42	.....	.....	54-55, 85	.....	37-39	.....	39
Radio.....	18-19	Throttle Related.....	49-50	.....	.....	66	.....	.....	54-55, 85	.....	37-39	.....	39
..... Antennas & Related.....	30	Throwout Bearing.....	66	.....	.....	69-70	.....	.....	54-55, 85	.....	37-39	.....	39
..... Knob.....	14	Tie Rod Ends & Related.....	69-70	.....	.....	43	.....	.....	54-55, 85	.....	37-39	.....	39
..... Speaker.....	20	Timing Chain Related.....	43	.....	.....	63	.....	.....	54-55, 85	.....	37-39	.....	39
Rag Joint Repair Kit.....	71	Transmission.....	63	.....	.....	62	.....	.....	54-55, 85	.....	37-39	.....	39
Roof Rail Weatherstrip.....	3	..... Cooler.....	62	.....	.....	63	.....	.....	54-55, 85	.....	37-39	.....	39
Sail Panel Insulation.....	13	..... Crossmember.....	63	.....	.....	18, 21	.....	.....	54-55, 85	.....	37-39	.....	39
Seat.....	Adjust Handle Knob & Retainer... 6	..... Control Selector Indicator.....	18, 21	.....	.....	62	.....	.....	54-55, 85	.....	37-39	.....	39
..... Back Latch Knobs.....	6	..... Dipstick, Tube.....	62	.....	.....	62	.....	.....	54-55, 85	.....	37-39	.....	39
..... Belt & Related.....	6-8, 80	..... Filter & Gasket Kit.....	62	.....	.....	85	.....	.....	54-55, 85	.....	37-39	.....	39
..... Foam.....	6	..... Hardware.....	85	.....	.....	62	.....	.....	54-55, 85	.....	37-39	.....	39
..... Hinge Cover.....	6	..... Inspection Plate.....	62	.....	.....	62	.....	.....	54-55, 85	.....	37-39	.....	39
Sheet Metal.....	35-36	..... Kick-down Cable.....	62	.....	.....	62	.....	.....	54-55, 85	.....	37-39	.....	39
Shift.....	Boot.....	..... Modulator.....	62	.....	.....	63	.....	.....	54-55, 85	.....	37-39	.....	39
..... Improver Kit.....	20, 21	..... Mount.....	63	.....	.....	62	.....	.....	54-55, 85	.....	37-39	.....	39
..... Indicator (Column).....	63	..... Oil Pan.....	62	.....	.....	62-64	.....	.....	54-55, 85	.....	37-39	.....	39
..... Indicator (Console).....	18	..... Section.....	62-64	.....	.....	21	.....	.....	54-55, 85	.....	37-39	.....	39
..... Knob.....	21	..... Selector Bezel / Dial.....	21	.....	.....	55	.....	.....	54-55, 85	.....	37-39	.....	39
..... Lever Insulator.....	18	..... Swap Mount Kit.....	55	.....	.....	27	.....	.....	54-55, 85	.....	37-39	.....	39
..... Lever Knob.....	17	Trunk.....	Divider Board.....	27	.....	28	.....	.....	54-55, 85	.....	37-39	.....	39
..... Linkage Repair Kit.....	63, 85	.....	.....	.....	.....	.....	.....	.....	54-55, 85	.....	37-39	.....	39
..... Rod Insulator.....	21	.....	.....	.....	.....	.....	.....	.....	54-55, 85	.....	37-39	.....	39
Shifter.....	Parts (Column).....	17-18	.....	.....	.....	.....	.....	.....	54-55, 85	.....	37-39	.....	39
..... Parts (Floor).....	20-22	.....	.....	.....	.....	.....	.....	.....	54-55, 85	.....	37-39	.....	39
..... Selector Cable.....	21	.....	.....	.....	.....	.....	.....	.....	54-55, 85	.....	37-39	.....	39
Shock Tower Covers.....	36	.....	.....	.....	.....	.....	.....	.....	54-55, 85	.....	37-39	.....	39
Shocks.....	69	.....	.....	.....	.....	.....	.....	.....	54-55, 85	.....	37-39	.....	39
Sound Deadener.....	10, 27	.....	.....	.....	.....	.....	.....	.....	54-55, 85	.....	37-39	.....	39

**BF** Boxing Fee    **OS** Oversize    **TF** Truck Freight



**WARNING:**

**Products in this catalog may contain chemicals known to the State of California to cause cancer, birth defects, or other reproductive harm.**

**For more information, visit [www.P65Warnings.ca.gov](http://www.P65Warnings.ca.gov) .**

We sell the highest quality weatherstrip available at competitive prices. All of our weatherstrip carries a 1-year warranty. Must retain your invoice to file a warranty claim. No invoice – No claim.



**RADIATOR SUPPORT-TO-HOOD SEAL**

28" x 2 3/4". Includes clips.

'70 – '77	Maverick 250 / 302 A/T; '71 – '77 Comet 250 / 302 A/T.
	..... D1DZ-8326A .....ea ..... 24.95

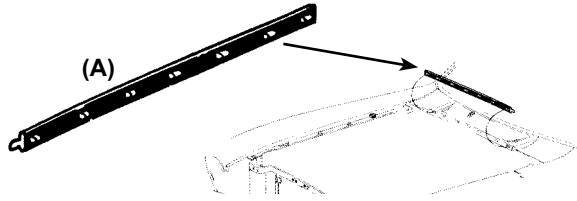

**HOOD-TO-COWL SEALS (A)**

'70 – '72	Maverick; '71 – '72 Comet.
	..... D0DZ-16740A .....ea ..... 17.50
'73 – '77	..... D3DZ-16740 .....ea ..... 17.50

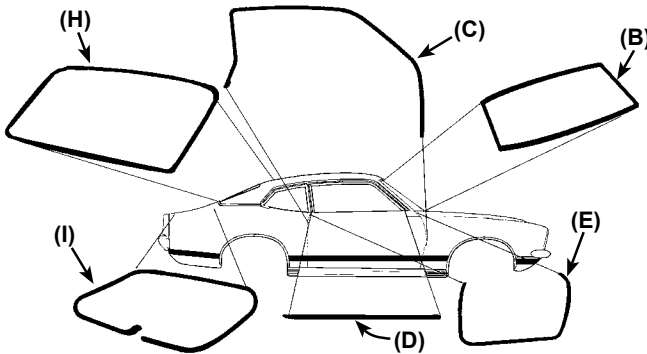

Typical Maverick / Comet 2-Door Weatherstrip

**WINDSHIELD WEATHERSTRIP (B)**

'70 – '77	..... D2DZ-6203110A .....ea ..... 79.95
-----------	---

**ROOF RAIL WEATHERSTRIP (C)**

'70 – '77	2-door sedan.
	..... D0DZ-6251222 .....pr ..... 129.95

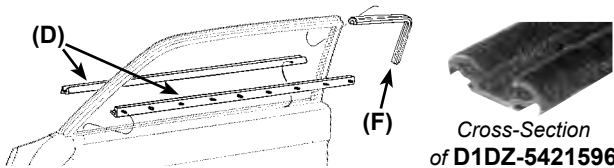

Cross-Section of D1DZ-5421596

**BELTLINE WEATHERSTRIP KIT (D)**

Includes inner and outer beltline for all doors.

'70 – '77	2-door sedan.
	4 pieces.
	..... D0DZ-6221452 .....kit ..... 89.95
'71 – '77	4-door sedan.
	8 pieces. Made in the USA.
	..... D1DZ-5421452 .....kit ..... 109.95



**DOOR WEATHERSTRIP (E)**

Sides and lower door only. 1 pair does 2 doors.

**NOTE:** 4-door sedan door weatherstrip not available.

'70 – '77	2-door sedan.
	..... D0DZ-6220530-1 .....pr ..... 79.95

**DOOR GLASS RUN (F)**

Black mohair lining material with black rubberized backing (1 1/4" wide). One piece does one front or back door. Fits in window channel. 10' long.

'70 – '77	..... D1DZ-5421596 .....ea ..... 19.95
-----------	--

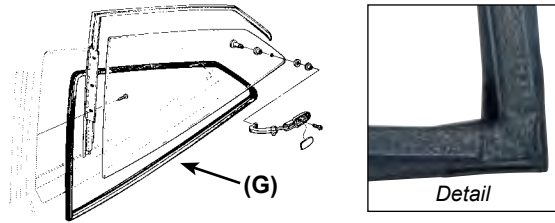

**QUARTER WINDOW SEALS (G)**

LH and RH. Includes black windlace. Made in the USA.

'70 – '77	2-door sedan.
	..... D0DZ-6230248PR .....pr ..... 99.95

**BACK GLASS WEATHERSTRIP (H)**

'70 – '77	2-door sedan.
	..... D0DZ-6242084 .....ea ..... 59.95
'71 – '77	4-door.
	..... D1DZ-5442084 .....ea ..... 79.95

**TRUNK WEATHERSTRIP (I)**

'70 – '77	..... D5DZ-6643720A .....ea ..... 29.95
-----------	---

**WEATHERSTRIP KIT**

This kit is offered at a discount over purchasing items individually. Items cannot be substituted, added to, or subtracted from these kits. Returns of individual items will be handled with replacements only. No partial refunds.

Kit includes the following:

- hood-to-cowl seal
- windshield weatherstrip
- both pieces of roof rail weatherstrip
- beltline weatherstrip (4-piece kit)
- LH and RH door weatherstrip
- LH and RH door glass run
- LH and RH quarter window seals
- back glass weatherstrip
- trunk weatherstrip

'70 – '77	2-door sedan.
	..... WSKITMV .....kit ..... 573.39

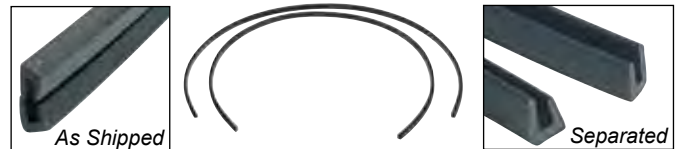

**QUARTER PANEL EXTENSION SEALS**

Two seals extruded as one piece. Must split to make pair.

'70 – '73	..... D0MZ-16D130A .....pr ..... 4.95
-----------	---------------------------------------



**GRILLE LAMP LENS GASKETS**

'71 – '74	..... C9WY-13211 .....pr ..... 2.95
-----------	-------------------------------------



**PARKING LAMP LENS GASKETS**

'70 – '72	..... D0DZ-13211A .....pr ..... 6.95
-----------	--------------------------------------



**REAR MARKER LAMP LENS GASKETS**

**NOTE:** These are a little thicker than OE, but they will work.

'70 - '77 ..... D0ZZ-15209.....pr ..... 2.50



**REAR MARKER LAMP-TO-BODY SEALS**

Goes between lamp housing and car body.

'71 - '77 ..... D1DZ-15A447A .....pr ..... 9.95

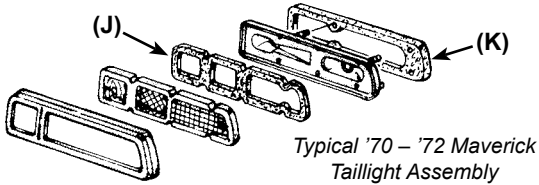

**D0DZ-13461B**

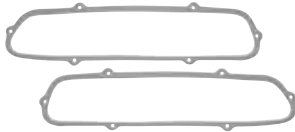

**D0GY-13461B**



**D0DZ-13420B**



**D0GY-13A495D**

**TAILLIGHT LENS GASKETS (J)**

'70 - '77 Maverick..... D0DZ-13461B.....pr ..... 4.95

'71 - '77 Comet.  
 ..... D0GY-13461B .....pr ..... 10.95

**TAILLIGHT-TO-BODY PADS (K)**

'70 - '77 Maverick..... D0DZ-13420B.....pr ..... 9.95

'71 - '77 Comet.  
 ..... D0GY-13A495D.....pr ..... 12.95



**LICENSE PLATE LAMP LENS GASKET**

'70 - '76 Maverick; '71 - '72 Comet.

..... C7AZ-13568A .....ea ..... 1.00



**SPORT MIRROR PADS**

'70 - '77 Maverick; '71 - '72 Comet; all with sport mirrors.

..... D0DZ-17724B/C .....pr ..... 24.95



**DOOR HANDLE PADS**

Set of 4 pads. Requires 1 set for 2-door, 2 sets for 4-door.

'70 - '77 Maverick; '71 - '72 Comet.

..... 67HP .....set ..... 4.95



**DOOR / TRUNK LOCK CYLINDER GASKET**

'70 - '77

..... C7AZ-6243625 .....ea ..... 1.50



**D0DZ-6201738**



**D1ZZ-9008**

**STEERING COLUMN-TO-FIREWALL SEAL**

'70 - '77 ..... D0DZ-6201738 .....ea ..... 15.95

**FUEL FILLER PIPE-TO-TRUNK FLOOR SEAL**

'71 - '77 ..... D1ZZ-9008 .....ea ..... 28.95



**D1ZZ-9072**



**E1AZ-9072B**

**FUEL TANK-TO-FILLER PIPE SEALS**

'71 - '75 Maverick before 5/1/75; '72 Comet.

..... D1ZZ-9072 .....ea ..... 19.95

'75 - '77 Maverick / Comet after 5/1/75.

..... E1AZ-9072B .....ea ..... 19.95



**FUEL FILLER PIPE NECK-TO-BODY GASKET**

'70 - '77

..... D1DZ-9076A .....ea ..... 1.00



**CLUTCH PEDAL ROD-TO-FIREWALL SEAL**

'70 - '77 '70 - '77 Maverick 6- or 8-cylinder; '71 - '72 Comet 6- or 8-cylinder; '73 - '77 Comet 8-cylinder.

..... C6OZ-7A533C .....ea ..... 10.95



**C6OZ-7513C**



**C6GY-7513A**

**CLUTCH RELEASE LEVER DUST SHIELDS**

'71 - '72 '71 Comet 302; '72 Maverick 302; '72 Comet 250.

..... C6OZ-7513C .....ea ..... 19.95

'73 - '77 6-cylinder..... C6GY-7513A .....ea ..... 19.95



**ALTERNATOR SPLASH SHIELD**

'70 - '77 6-cylinder with factory A/C.

..... D1DZ-10317A .....ea ..... 18.95



**WEATHERSTRIP ADHESIVE**

High-quality black adhesive. Strong, flexible and rubbery. Can withstand vibration and extreme temperature variations.

Can be used to bond automotive weatherstripping, and is a great adhesive for holding paper, cork or rubber gaskets in place during installation. Not recommended for windshield or back glass weatherstrip.

5 oz. tube ..... 3M08008 .....ea ..... 8.95



**3M AUTO BEDDING & GLAZING COMPOUND**

For use with windshield installation as a supplementary sealer. Also used to set water shields. Black.

10 oz. cartridge..... 3M08509 .....ea ..... 15.95

**Bumpers, Plugs and Grommets**



**GLOVE BOX DOOR BUMPERS**

'73 - '77 ..... AV4246 .....pr ..... 1.00



**C2AZ-6223030A**



**C7AZ-54265A28**

**DOOR BUMPERS**

'70 - '72 Upper. Requires 2 per vehicle.  
 ⚙️ ..... C2AZ-6223030A .....ea ..... 1.00

'70 - '77 Requires 4.  
 ⚙️ ..... C7AZ-54265A28 .....ea ..... 1.00



**C7AZ-16758ASET**



**380478S**

**HOOD BUMPERS**

'70 - '77 Hood to fender. Push-on type. Set of 4.  
 ⚙️ ..... C7AZ-16758ASET .....set ..... 8.95

'70 - '77 Hood to cowl. Includes screw. Requires 2 per vehicle.  
 ..... 380478S .....ea ..... 1.95



**RADIATOR SUPPORT BUMPERS**

Round.

'70 - '77 ⚙️ ..... C5ZZ-16763B .....pr ..... 6.95



**UPPER FRONT SUSPENSION BUMPER**

Mounts on outer shock tower / coil spring cover. Rubber. Includes nut.

'70 - '77 requires 2 per vehicle.  
 ⚙️ ..... C9OZ-3020 .....ea ..... 9.95



**REAR AXLE BUMPER**

Requires 2 per vehicle.

'70 - '74 Maverick; '71 - '73 Comet.  
 ⚙️ ..... C6AZ-4730A .....ea ..... 8.95



**FLOOR PAN PLUG**

7/8". Rubber.

'71 - '73 Comet.  
 ⚙️ ..... 377949S .....ea ..... 1.50



**TRUNK FLOOR PLUG**

Fits 3/4" hole. 2 1/4" wide. Rubber.

'71 - '73 ..... 383796S .....ea ..... 2.95



**QUARTER PANEL DRAIN VALVES**

Use with 1 1/2" square hole.

'70 - '73 Maverick; '71 - '72 Comet.  
 ⚙️ ..... C7ZZ-6511202 .....pr ..... 9.95



**DRUM BRAKE ADJUSTMENT HOLE COVERS**

Oval plugs. 5/16" x 1". Set of 4.

'70 - '72 front drums; '70 - '77 rear drums.  
 ⚙️ ..... AK108 .....set ..... 3.00

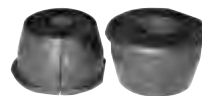

**EVAPORATOR-TO-COMPRESSOR A/C LINE GROMMETS**

At radiator support.

'72 6-cylinder with hang-on A/C.  
 ..... 378264S .....pr ..... 9.95



**FUEL LINE-TO-FENDER APRON GROMMET**

Rubber with 3/8" fuel line hole. Requires 1 per vehicle.

'70 - '77 ⚙️ ..... D0DZ-9K288A .....ea ..... 5.95

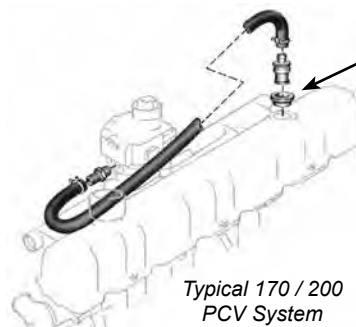

PCV Grommet

Typical 170 / 200 PCV System



**C8AZ-6A892**



**E7AZ-6A892A**

**PCV GROMMETS**

Give year and engine size when ordering.

'70 - '77 6- or 8-cylinder with oil filler cap that accepts elbow.  
 ⚙️ ..... C8AZ-6A892 .....ea ..... 2.95

'71 - '73 To oil filler cap. With 1" round hole.  
 ⚙️ ..... E7AZ-6A892A .....ea ..... 3.95



**Grommet Kit**

..... M6892F .....kit ..... 13.95



**AUTO KRAFTERS, INC. GOLD CARD CLUB**

- Save 10% on our already low prices\*
- Get expedited order shipping
- \$14.95 flat shipping on orders\*

**JOIN THE AUTO KRAFTERS GOLD CARD CLUB TODAY!**

Ask your salesperson for more information!

\*Some exclusions apply.



D1DZ-6560050



D1ZZ-6561692-01



**SEAT FOAM – HIGH BACK**

Does 1 seat. Requires 2 per car.

**NOTE:** This is an oversized item that requires additional shipping charges. Please call for a shipping quote.

'71 – '73 ..... D1DZ-6560050 ..... ea..... 129.95

**SEAT HINGE COVERS**

Outer. Black plastic; paint to match.

'71 – '73 ..... D1ZZ-6561692-01 ..... pr..... 24.95



**FRONT SEAT BACK LATCH RELEASE KNOBS**

Chrome-plated zinc with set screws installed.

'71 – '74 ..... D1FZ-6262622B/C ..... pr..... 29.95



C5AZ-6261753C



C5AZ-6261753BA

C5AZ-6262060A

**FRONT SEAT ADJUST HANDLE KNOB AND RETAINER**

'71 – '77 ..... '71 – '72 Comet with full-width or bucket seat; '72 Maverick with manual bucket seat; '73 – '77 Maverick with 2-way manual seat.

**NOTE:** Retainer is required to install knob.

**NEW** Chrome knob only ..... C5AZ-6261753C ..... ea..... 9.95

Black knob and retainer ..... C5AZ-6261753BA ..... ea..... 6.95

Retainer only ..... C5AZ-6262060A ..... ea..... 2.95

**Retro-Style Seat Belt Webbing Colors**



**NOTE:** While we take great care to present the colors as true as possible to the actual color, their accuracy is not guaranteed, due to the limitations of the printing process.

**BF** Boxing Fee    **OS** Oversize    **TF** Truck Freight

**Seat Belts and Related**

**RETRO-STYLE NON-RETRACTABLE LAP SEAT BELTS**



Meets or exceeds Federal Motor Vehicle Safety Standards.

For mounting hardware, see part # AK199 (see page 8).

**NOTE:** These are lap belts only. Does not include shoulder strap and will not work with shoulder strap.



258-BRD

**“Aviation-Style” Lift-Handle Buckle**

Chrome lift-up handle and chrome-plated floor anchors.

**Buckle:** 2<sup>3</sup>/<sub>8</sub>" × 2<sup>1</sup>/<sub>2</sub>".

**Webbing:** 1<sup>7</sup>/<sub>8</sub>" wide.

**60" belts:** 32" on the buckle side, 24" on the lap side.

**75" belts:** 48" on the buckle side, 24" on the lap side.

Please add to the end of the part number "60" for 60" or "75" for 75".

Color	60"	75"
Black	258-BLK- 22.95	24.95
Blue	258-BLU- 22.95	24.95
Bright Red	258-BRD- 22.95	24.95
Burgundy	258-BRG- 22.95	24.95
Brown	258-BRN- 22.95	24.95
Cobalt Blue	258-CBB- 22.95	24.95
Charcoal	258-CHR- 22.95	24.95
Copper	258-COP- 22.95	24.95
Dark Blue	258-DKB- 22.95	24.95
Dark Green	258-DKG- 22.95	24.95
Dark Red	258-DKR- 22.95	24.95
Green	258-GRN- 22.95	24.95
Gray	258-GRY- 22.95	24.95
Ivory	258-IVY 22.95	24.95
Maroon	258-MAR- 22.95	24.95
Medium Turquoise	258-MTQ- 22.95	24.95
Orange	258-ORN- 22.95	24.95
Powder Blue	258-PDB- 22.95	24.95
Silver	258-SIL- 22.95	24.95
Tan	258-TAN- 22.95	24.95
Turquoise	258-TRQ- 22.95	24.95
White	258-WHT- 22.95	24.95
Yellow	258-YEL- 22.95	24.95



268-BRG



Buckle Detail

**Push-Button Buckle**

Chrome buckle with starburst-design push-button and chrome-plated floor anchors.

**Buckle:** 2" × 2".

**Webbing:** 1<sup>7</sup>/<sub>8</sub>" wide .

**60" belts:** 23" on the fixed push-button side, 37" on the adjustable male buckle side.

**75" belts:** 23" on the fixed push-button side, 52" on the male buckle side.

Please add to the end of the part number "60" for 60" or "75" for 75".

Color	60"	75"
Black	268-BLK- 23.95	24.95
Blue	268-BLU- 23.95	24.95
Bright Red	268-BRD- 23.95	24.95
Burgundy	268-BRG- 23.95	24.95
Dark Blue	268-DKB- 23.95	24.95
Gray	268-GRY- 23.95	24.95
Powder Blue	268-PDB- 23.95	24.95
Tan	268-TAN- 23.95	24.95



**RETRO-STYLE  
RETRACTABLE SEAT BELTS**

Meets or exceeds Federal Motor Vehicle Safety Standards.

For mounting hardware, see part #AK199 on page 8.



**259-TAN**

***“Aviation-Style”  
Lift-Handle Buckle***

Chrome lift-up handle and chrome-plated floor anchors.

**Buckle:** 2 1/8" x 2 1/2".  
**Inertial Locking Retractor:** 3" x 2".  
**Webbing:** 1 7/8" wide .

**Lap Belts Only**

**Belt:** 70" (43" on retractor side, 27" on buckle side).

**NOTE:** These are lap belts only. Does not include shoulder strap and will not work with shoulder strap.

Black .....	259-BLK.....	ea.....	54.95
Bright Red .....	259-BRD.....	ea.....	54.95
Tan .....	259-TAN.....	ea.....	54.95

**Lap and Shoulder Belts**

Retractor holds 96" of webbing, with 39" of webbing outside, totaling over 11' of belt webbing. Buckle side is fully adjustable for maximum installation flexibility. This system uses an advanced inertial retractor that locks to support the upper and lower parts of the body in a sudden stop. Retractor may be mounted in either the horizontal or vertical positions.

**Belt:** 135" on the retractor side, 27" on the buckle side.

**NOTE:** Fabrication skills may be required to establish shoulder anchor point – please consult a professional installation specialist. Not for off-road or racetrack applications.

Black .....	359-BLK.....	pr.....	169.98
Blue .....	359-BLU.....	pr.....	169.98
Bright Red .....	359-BRD.....	pr.....	169.98
Burgundy.....	359-BRG.....	pr.....	169.98
Dark Blue .....	359-DKB.....	pr.....	169.98
Green .....	359-GRN.....	pr.....	169.98
Gray .....	359-GRY.....	pr.....	169.98
Powder Blue.....	359-PDB.....	pr.....	169.98
Tan .....	359-TAN.....	pr.....	169.98
Turquoise .....	359-TRQ.....	pr.....	169.98
White .....	359-WHT.....	pr.....	169.98



**269-TAN-12**



**269-TAN-20**

**Push-Button Buckle**

Chrome lift-up handle and chrome-plated floor anchors.

**Buckle:** 2" x 2".

**Inertial Locking Retractor:** 3" x 2".

**Webbing:** 1 7/8" wide.

**Lap Belts Only**

**Belts (Bucket):** 55" (43" on retractor side, 12" hard plastic sleeve on buckle side).

**Belts (Bench):** 63" (43" on retractor side, 20" on buckle side).

**NOTE:** Bench seat belts may also be used on bucket seats, but they will lack the plastic sleeve on the buckle side.

**NOTE:** These are lap belts only. Does not include shoulder strap and will not work with shoulder strap.

Please add to the end of the part number "12" for bucket seat or "20" for bench seat.

Color		Bucket	Bench
Black .....	269-BLK-	54.95	59.95
Bright Red .....	269-BRD-	54.95	59.95
Tan .....	269-TAN-	54.95	59.95

**RETRO-STYLE RETRACTABLE SEAT BELTS CONTINUED**

***Push-Button Buckle Continued***



**369-TAN-20**

**Lap and Shoulder Belts**

Retractor holds 96" of webbing, with 39" of webbing outside, totaling over 11' of belt webbing. The buckle side is fully adjustable for maximum installation flexibility. This system uses an advanced inertial retractor that locks to support both the upper and lower parts of the body in the

event of a sudden stop. Retractor may be mounted in either the horizontal or vertical positions. Sold in pairs.

**Belts (Bucket):** 135" on retractor side, 12" hard plastic sleeve on buckle side.

**Belts (Bench):** 135" on retractor side, 20" on buckle side.

For mounting hardware, see part # AK200 on page 8.

**NOTE:** Fabrication skills may be required to establish shoulder anchor point – please consult a professional installation specialist. Not for off-road or racetrack applications.

Color	Bucket	Bench	
Black .....	369-BLK-12...	369-BLK-20 ..	169.98
Blue .....	369-BLU-12...	369-BLU-20 ..	169.98
Bright Red .....	369-BRD-12 ..	369-BRD-20...	169.98
Burgundy.....	369-BRG-12..	369-BRG-20 ..	169.98
Dark Blue .....	369-DKB-12 ..	369-DKB-20...	169.98
Gray .....	369-GRY-12 ..	369-GRY-20...	169.98
Powder Blue.....	369-PDB-12 ..	369-PDB-20...	169.98
Tan .....	369-TAN-12...	369-TAN-20 ...	169.98

**REPLACEMENT-STYLE SEAT LAP BELTS – 60"**

Includes hardware.

**NOTE:** These are lap belts only. Does not include shoulder strap and will not work with shoulder strap.

**Push-Button Release Type**



**Rectangular Button**

Steel fixtures. Maroon..... SB-04.....ea ..... 24.95



**Round Button**

Black only. Button features starburst pattern.

..... SB6001PB .....ea ..... 34.95



***“Aviation-Style” Lift-Handle Release Type***

**Smooth Chrome-Plated Fixtures**

Maroon..... SB6004.....ea ..... 28.50



**Wrinkle Finish Black Handle**

Black only.

..... SB6001W.....ea ..... 39.95

**REPLACEMENT-STYLE SEAT LAP BELTS – 74"**

Includes hardware.

**NOTE:** These are lap belts only. Does not include shoulder strap and will not work with shoulder strap.



**Push-Button Release Type**

With steel fixtures.

..... SB7401 .....ea ..... 24.95

**Lift-Handle Release Type**



**Smooth, Polished Latch Handle**

Dark Saddle ..... SB7410 ..... ea ..... 29.95



**Wrinkle Latch Handle**

Black..... SB7401W.....ea ..... 39.95

**SEAT BELT MOUNTING HARDWARE**



**382626-S**



**382627S**

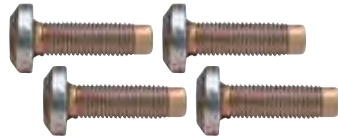

**384966-S**



*Head Detail*

**Torx-Head Bolts**

Yellow zinc plated. May be correct for some factory applications. Can also be used when adding aftermarket belts if you want the Torx-style bolt. Verify measurements before ordering. Made in the USA.

**Shoulder Harness Bolt**

3/8" – 16 threads, 1 1/2" long with .23" long shoulder.  
..... 382626-S ..... ea ..... 6.95

**Seat Belt Bolt**

7/16" – 20 threads, 1 3/4" long with 1/2" long shoulder.  
..... 382627S ..... ea ..... 8.95

**Rear Seat Belt Bolt Set**

7/16" – 20 threads, 1 3/4" long, full threads with lead point. Set of 4.  
..... 384966-S ..... set ..... 6.00

**Hardware Kits – Grade 5**



**Lap Belt Kit**

Includes (2) grade-5 bolts, (2) grade-5 nuts, (2) flat washers, and (2) lock washers. 7/16" – 20 threads.  
..... AK199 ..... kit ..... 2.50

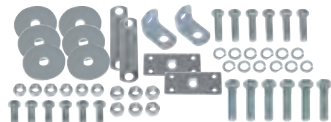

**Shoulder Harness Kit**

Includes (12) nuts, (18) grade-5 bolts, (12) lock washers, (6) flat washers, anchors, and L-brackets to install (2) lap and shoulder belts. All hardware is zinc coated for an attractive finish.

**NOTE:** Not for off-road or racetrack applications.  
..... AK200 ..... kit ..... 39.95



**SEAT BELT BUCKLE BUTTON INSERT**

Peel-and-stick insert for seat belt buckle release buttons. Round, silver-colored with a black ring surrounding a starburst pattern inside the disc.

'70 – '72 All ..... DF1523 .....ea ..... 11.50



**SEAT BELT BUCKLE RESTORATION KIT**

Kit contains 2 buckle surrounds and 2 button covers.

'70 Deluxe interior ..... C8AZ-65611A72K..... kit ..... 35.95



**FRONT SEAT SHOULDER HARNESS STRAP BOOT**

Black plastic. Made exactly like original. Requires 2 per vehicle.

'71 – '73 '71 – '72 Maverick / Comet; '73 Maverick without integral seat belt and shoulder harness.  
..... D1AZ-6560235 ..... ea ..... 12.95

**Corinthian Grain Vinyl Colors**

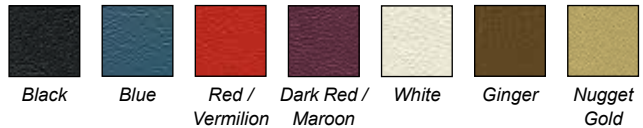

**DOOR PANELS**



Concours-quality panels reproduced in detail to include the correct-style chrome Mylar trim and correct Corinthian grain vinyl in factory-original colors. Correct hole locations are die-cut on the back side for an exact fit when installed. Does not include the upper reinforcement, attaching weather-strip, or emblems.

Most original colors available. When ordering, please specify color choice by adding color code to the end of the part number (example: DP73MV62-03DC for red panels for '73 – '76 with Deluxe interior).

**NOTE:** Door panels are custom-made special-order items only and are not returnable for any reason. Defects due to poor workmanship or mis-packaged items will be replaced as a warranty item. Refunds are not available.

Please allow 3 to 4 weeks for delivery.

**NOTE:** Some items are oversized and require additional shipping charges. Please call for a shipping quote.



**DP70MV62-02**

'70 – '72 2-door sedan with standard interior. Black (01), Blue (02), Dark Red / Maroon (04), Nugget Gold (22). Standard interior.  
..... DP70MV62- ..... pr ..... 335.95  
'71 – '72 2-door sedan with standard interior. Vermilion.  
..... DP71MV62-03STD ..... pr ..... 335.95

**NOTE:** While we take great care to present the colors as true as possible to the actual color, their accuracy is not guaranteed, due to the limitations of the printing process.

**BF** Boxing Fee    **OS** Oversize    **TF** Truck Freight

**DOOR PANELS CONTINUED**



**DP71MV62-03**



**DP71MV62-02BW**

'71 - '72 2-door sedan with Deluxe interior.  
Black (01), Blue (02), Red / Vermilion (03), Nugget Gold (22).

**Woodgrain inserts.**

..... DP71MV62- ..... pr..... 359.95

**Basketweave inserts.**

..... DP71MV62- BW..... pr..... 359.95



**DP73MV62-03LDC**

'73 - '75 2-door sedan with Luxury Decor option.  
Black (01), Blue (02), Red (03), White (05), Ginger (20).

..... DP73MV62- LDC ..... pr..... 359.95



**DP73MV62-02DC**

'73 - '76 2-door sedan with Deluxe interior.  
Black (01), Blue (02), Red (03), White (05) Ginger (20).

..... DP73MV62- DC ..... pr..... 359.95



**DP73MV62-20**

'73 - '77 2-door sedan with standard interior.  
Black (01), Blue (02), Red (03), White (05), Ginger (20).

..... DP73MV62- ..... pr..... 335.95



**DP76MV62-02LDC**

'76 - '77 2-door sedan with Luxury Decor option.  
Black (01), Blue (02), Red (03), White (05), Ginger (20).

..... DP76MV62- LDC ..... pr..... 359.95



**TRIM / DOOR PANEL REMOVER**

Removes any auto body trim pad instantly. Just insert the tool and pull the trim pad up..... 15K127 .....ea ..... 8.95



**TRIM REMOVAL KIT**

Made to remove door panels, interior panels, window mouldings, and more. Constructed of impact-resistant plastic, the tools will not scratch surfaces the way metal tools can. Includes 11 tools and comes with a heavy-duty storage pouch.

..... TX2684 ..... kit ..... 19.95



**DOOR BOARDS**

'73 - '77 Maverick with pull handle-style arm rest and recessed-type door handle .... FM042..... pr..... 69.95



**DOOR WATER SHIELDS**

These watershields have knocks for both early- and late-style arm rests. Made in the USA.

'70 - '77 2-door.  
 ..... MA110..... pr..... 9.95



**WSP102**

**WSP101**

**Universal Water Shield Material**

12' x 2' roll ..... WSP102..... ea ..... 29.95

12' x 4' roll ..... WSP101..... ea ..... 39.95



**ARM REST BASE**

Black plastic. For 10½" pad.

'70 - '72 LH or RH.  
 ..... D3DZ-6224144 ..... ea ..... 24.95

**Arm Rest Vinyl Colors**



**D00Z-6224100-02**

**D10Z-65241001-20**

**ARM REST PADS**

'70 2-door.  
8½" long x 2¼" wide x 3⅜" high.  
Black (01), Blue (02).

LH or RH ..... D00Z-6224100- ..... ea ..... 49.95

'71 - '72 2- or 4-door with 8½" pad. Front or rear.  
8½" long x 2¼" wide x 3⅜" high.  
Black (01), Blue (02).

LH or RH.  
 ..... D00Z-6224100- ..... ea ..... 49.95

'71 - '72 With 10½" pad.  
10½" long x 2½" wide x ¾" high. Exact reproduction.  
Black.

LH.  
 ..... D10Z-6524101-01 ..... ea ..... 34.95

RH.  
 ..... D10Z-6524100-01 ..... ea ..... 34.95

Blue (02), Red (03), White (05), Green (13), Ginger (20).

LH and RH.  
 ..... D10Z-65241001- ..... pr..... 69.90

**NOTE: We have marked with a those parts which also fit corresponding Mercury models, such as Comet.**



**C6AZ-6224146B**



**AK236**

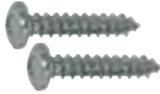

**AK273**

**ARM REST CLIPS AND SCREWS**

**Clips**

'70 - '77	'70 - '72 Maverick; '73 - '77 Maverick without molded arm rest;		
	'71 - '72 Comet without molded arm rest.		
	C6AZ-6224146B	ea	3.50

**Screws**

Set of 2.			
'70 - '77	Hex washer head.		
	AK236	pr	1.00
	Phillips pan head.		
	AK273	pr	1.00



**D1DZ-6202344-5**



**D4DZ-6202344-5**

**KICK PANELS**

Excellent reproduction left and right panels made of durable black ABS plastic and featuring a grained surface. Can be dyed to desired color with automotive dyes. Made in the USA.

'70 - '72	Maverick; '71 - '72 Comet.		
	D1DZ-6202344-5	pr	84.95
'73	With lower dash tray.		
	D1DZ-6202344-5	pr	84.95
'73	With glove box.		
	D4DZ-6202344-5	pr	84.95
'74 - '77			
	D4DZ-6202344-5	pr	84.95



**D0DZ-6213208A**



**71STEP**

**STEP PLATES**

Each pair includes step plate labels. Attaching hardware sold separately.

'70	2-door sedan	D0DZ-6213208A	pr	129.95
'71 - '77	2-door sedan.			
<b>NOTE:</b> Must relocate (drill) 2 holes for '74 - '77.				
		71STEP	pr	59.95



**STEP PLATE LABEL**

Features blue Ford oval. Peel-and-stick. Labels are sold separately on an individual basis or are included at no additional charge when you order step plates.

'71 - '77	SPL-2	ea	3.50
-----------	-------	----	------



**STEP PLATE SCREWS**

Phillips oval head. 3/4" long. Set of 12.

'70 - '77	2-door. '70 requires 8, '71 - '77 requires 12.		
	AK120	set	2.75

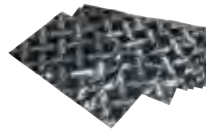

**DYNAMAT® EXTREME HEAT SHIELD AND SOUND DEADENER**

This thermo-acoustic control material will give you a cool, quiet ride. Dynamat® Extreme eliminates road noise and engine noise, giving your vehicle a new feel. Applying Dynamat® to the sheet metal surrounding your speakers will eliminate speaker distortion, vibration, rattles and squeaks. Easy peel-and-stick application for doors, floor, roof and trunk. Contains 9 sheets which add up to a total of 36 sq. ft of material.

For installation rollers, see part #10005 or #10007 below.

	20455	ea	199.95
--	-------	----	--------



**Dynamat® Extreme Installation Rollers**

Helps achieve the strongest bond possible when applying Dynamat®.

Wood				
	1 1/8"	10005	ea	14.95
Rubber				
	2"	10007	ea	24.95

**74X46**



**72X48BF**

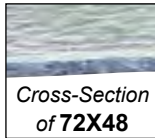

**Cross-Section of 72X48**

**HEAT SHIELD AND SOUND DEADENER**

This quality heat shield insulation gives owners the opportunity to use space-age technology in keeping heat and noise out of their driving and listening environment. Consists of one sheet of 99.5% pure industrial grade aluminum laminated to 3/8" padding, achieving the highest deflection of heat and muting of sound when placed with the aluminum side toward the heat and / or noise source.

74" x 46"		74X46	ea	62.95
-----------	--	-------	----	-------



**Cross-Section of 72X48BF**

**INSULATOR AND SOUND DEADENER WITH BUBBLE FILM**

This reflective foil insulation consists of 2 layers of polyethylene bubble film sandwiched between two layers of 99.9% pure aluminum foil, making it 5/16" thick. Temperature range from 60° F to 180° F. Works great for insulating headliners, floor pans, trunk area, door panels, kick panels, etc. Cut and form into needed shapes using scissors and apply with contact cement or weatherstrip adhesive.

72" x 48"		72X48BF	ea	29.95
-----------	--	---------	----	-------



**FATMAT® RATTLE TRAP SOUND DEADENER - 50 SQ. FT.**

Bulk roll - 50 sq. ft. (33 1/2" x 18") x 80 mil thick. Features aggressive adhesive backing that can be installed at almost any temperature. Requires no heat to install and is great for exterior noise reduction, insulation, and improving sound system quality. Includes installation kit (containing roller and instruction sheet). Manufacturer's lifetime warranty.

	RATPAK50	ea	159.95
--	----------	----	--------



**PERMATEX® TRIM ADHESIVE**

Recommended for installation of carpet, headliners, upper quarter trim panels, hood insulation, trunk mats, etc. Also recommended for repair of sunvisors or anywhere you need a good adhesive. Aerosol.

<b>82019</b>	<b>27828</b>			
<b>NOTE:</b> Aerosol products cannot be shipped via air.				
		Standard. 16 oz.		
		82019	ea	10.95
		27828	ea	17.95



**MISTY® HEAVY-DUTY TRIM ADHESIVE**

Can be used on a variety of surfaces, uneven or porous, for temporary or permanent bonding. The wide web spray pattern dries clear and is waterproof and non-staining. Contains no chlorinated solvents and is ozone non-depleting.

**Caution:** Please read all directions carefully. This adhesive is extremely flammable and harmful if swallowed. Eye irritant. Please keep away from children. Made in the USA.

**NOTE:** Aerosol products cannot be shipped via air.

12 oz. aerosol..... A00315 ..... ea..... 9.95

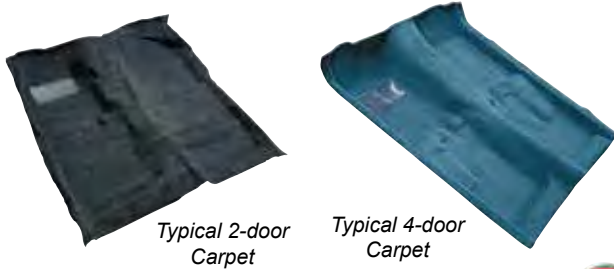

Typical 2-door Carpet

Typical 4-door Carpet

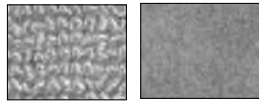

Loop Pile

Cut Pile

**FLOOR COVERING – CARPET**



We are proud to offer high quality carpet from ACC®, the world's leading manufacturer of automotive floor coverings. Made from top-quality original-type material and features a heavy 36 oz. jute backing. Molded to floor contours for easy installation.

**Loop Pile Carpet Colors**



Available in the following colors:

- Black (01)
- Maroon (04)
- Dark Saddle (10)
- Dark Green (13)
- Dark Aqua (18)
- Gunmetal Gray (23)
- Blue (02)
- Dark Blue (08)
- Dark Brown (11)
- Moss Green (14)
- Emberglow (19)
- Charcoal Gray (24)
- Bright Red (03)
- Light Saddle (09)
- Ivy Gold (12)
- Aqua (16)
- Ginger (20)

Available in loop pile or cut pile

Please specify color and pile type by adding the color code followed by the pile code ("CP" for cut pile, "LP" for loop pile) to end of the part number when ordering (example: CP70MV62-03LP for bright red loop pile for a 2-door).

Please specify year, body, and color when ordering.

**NOTE: All carpet is custom-made and is NOT returnable for any reason. Please ask for a color sample when ordering if you are looking for a particular color. Only defective carpet will be replaced.**

**NOTE:** These items are oversized and require additional shipping charges. Please call for a shipping quote.

'70 – '73	2-door.		
		CP70MV62-	set.... 171.95
'71 – '73	4-door.		
		CP70MV54-	set.... 171.95
'74 – '77	2-door.		
		CP74MV62-	set.... 171.95
		CP74MV54-	set.... 171.95

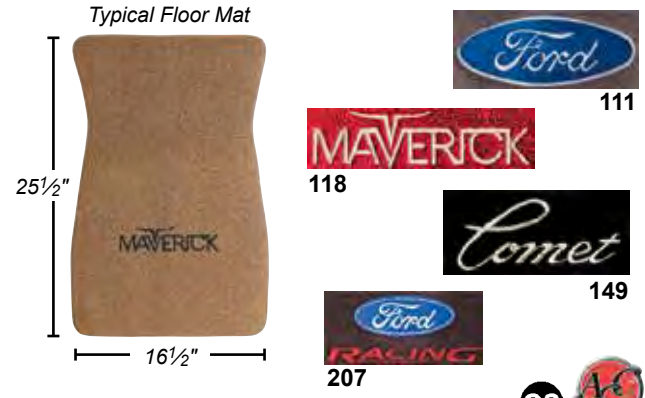

**FLOOR MATS**

Carpet mats with vinyl binding. Please specify color of carpet by adding color code to the end of the part number (after the hyphen) when ordering. Send color samples if in doubt.

**Loop Pile Carpet Colors**



**Carpet Colors:**

- Black (01)
- Maroon (04)
- Dark Saddle (10)
- Ginger (20)
- Gold (35)
- Blue (02)
- Dark Blue (08)
- Dark Brown (11)
- Charcoal Gray (24)
- Red (03)
- Light Saddle (09)
- Dark Green (13)
- Light Gray (32)

**Logos Available:** Ford oval (#111), Maverick (#118 – default logo for FM2MV and FM4MV), Comet (#149), and Ford Racing (#207). Maverick and Comet logo colors available in Black (B), White (W), Red (R), Silver (S). Ford oval is available only in blue and silver. Ford Racing logo is available only in blue, silver and red.

Logos are available on **front mats only**. Rear mats are plain.

Please specify desired logo by adding the logo number to the end of the part number, after the color code, when ordering (example: FM2MV-02118S for a set of 2 blue mats with silver Maverick logos).

**NOTE: These mats are universal (dimensions shown above) and are NOT a custom form fit. They are made to your color specifications and are NOT returnable for any reason. Please ask for a color sample when ordering if you are looking for a particular color. Only defective floor mats will be replaced. No returns.**

**NOTE:** These items are oversized and require additional shipping charges. Please call for a shipping quote.

Set of 2	Maverick..... FM2MV-	pr..... 114.95
	Comet.	
		FM2CM-
		pr..... 114.95
Set of 4	Maverick..... FM4MV-	set.... 145.95
	Comet.	
		FM4CM-
		set.... 145.95

**NOTE: While we take great care to present the colors as true as possible to the actual color, their accuracy is not guaranteed, due to the limitations of the printing process.**

**BF** Boxing Fee      **OS** Oversize      **TF** Truck Freight

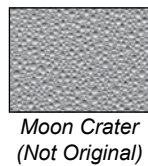
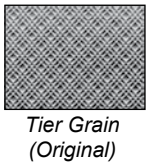

**HEADLINERS**

Our headliners are made from original patterns and original-type materials (tier grain). Colors listed below. If in doubt, send sample. Please add color code to the end of the part number when ordering.

**NOTE:** Moon crater material, though not an original material, is also available. Please call for availability and samples.

'70 - '77	2-door.		
	Black.		
		HL70MV62-01	ea..... 99.95
		Bright Red (03), Maroon (04), White (05), Dark Blue (08), Light Saddle (09), Ginger (20), Light Gray (26), Medium Blue (29).	
		HL70MV62-	ea..... 119.95
'71 - '77	4-door.		
	Black.		
		HL70MV54-01	ea..... 99.95
		Blue (02), Light Blue (07), Saddle (09).	
		HL70MV54-	ea..... 119.95

**HEADLINER MATERIAL**

36" x 54". Please indicate color choice by adding color code to the end of the part number when ordering.

**Tier Grain Headliner Colors**



**Tier Grain**

Available in the following colors:

- Black (01)
  - White (05)
  - Light Saddle (09)
  - Ginger (20)
  - Bright Red (03)
  - Light Blue (07)
  - Dark Brown (11)
  - Light Gray (26)
  - Maroon (04)
  - Dark Blue (08)
  - Dark Green (13)
  - Medium Blue (29)
- 1 yard..... HLYDTR- ..... ea..... 39.95

**Moon Crater Headliner Colors**

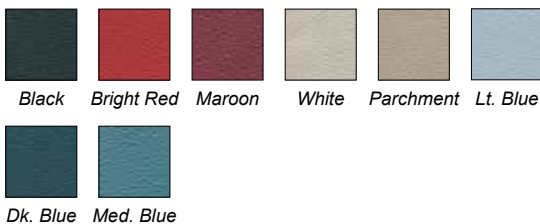

**Moon Crater**

Available in the following colors:

- Black (01)
  - White (05)
  - Dark Blue (08)
  - Bright Red (03)
  - Parchment (06)
  - Medium Blue (29)
  - Maroon (04)
  - Light Blue (07)
- 1 yard..... HLYDMC- ..... ea..... 39.95

**NOTE:** While we take great care to present the colors as true as possible to the actual color, their accuracy is not guaranteed, due to the limitations of the printing process.

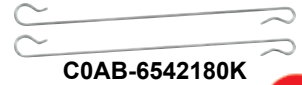
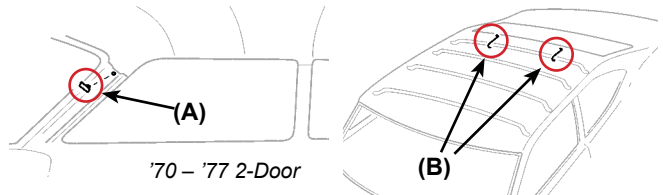

**HEADLINER RETAINERS**

**Front Retainers (A)**

Small plastic retainers at the tops of the windshield posts. Black.

'70 - '77	D3DZ-6252136A	pr..... 11.95
-----------	---------------	---------------

**Rear Rod Retainers (B)**

Holds the rear headliner rod in place, attaches to the roof. 4" long.

	C0AB-6542180K	pr..... 3.95
--	---------------	--------------



**SUNVISORS**

Tier grain vinyl. Where applicable, please add color code to the end of the part number when ordering.

'70 - '77	2-door.	
	Made in the USA.	
	Black only	SV70MV62-01 pr..... 89.95
	Import.	
	Black (01), Bright Red (03), Maroon (04), White (05), Dark Blue (08), Ginger (20), Gray (26).	
		D0DZ-6204104 pr..... 89.95



**SUNVISOR ANCHOR PINS**

'70	Anchor pin only	C3DZ-7604114B	ea..... 5.95
'71 - '77	After 5/3/71.		
	Includes tip.		
		D3AZ-6504114B	ea..... 5.95



**SUNVISOR TIPS**

Gray.

'70 - '77		VT1	pr..... 2.00
-----------	--	-----	--------------

**SUNVISOR CENTER CLIPS**

'70 - '71	Black.		
		C8ZZ-6504132-01	ea..... 14.95
	White.		
		C8ZZ-6504132-05	ea..... 16.95



**SUNVISOR BRACKET**

Chrome reproduction. LH or RH.

'70 - '76	Before 10/1/75.		
		C9AZ-6204144A	ea..... 27.95



**FIREWALL INSULATOR**

Molded from OE pattern. Includes mounting pins.



**NOTE:** This is an oversized item; additional shipping charges apply.

'71 - '77 ..... D1DZ-5401670 ..... ea..... 199.95



**FIREWALL INSULATION RETAINER**

Rubber.

'70 - '72 ..... C8ZZ-6501691A ..... ea..... 1.95



**UNIVERSAL FIREWALL PAD**

Moldable 3' x 5' pad. 1" thick. Solid, no holes.

'73 - '77 ..... SR105 ..... ea..... 79.95



**SAIL PANEL INSULATION SET**

'70 - '77 ..... FAM720 ..... set..... 15.95



**D4AZ-18495A**

**74612**

**HEATER CONTROL VALVES**

'76 - '77 After 5/3/76. Genuine Ford.

..... D4AZ-18495A ..... ea..... 39.95

'76 - '77 Maverick after 5/3/76 with factory-installed A/C; Comet after 5/3/76. Import.

..... 74612 ..... ea..... 19.95



**HEATER BOX CLIP**

Holds the heater box that houses the heater core. Quantity varies by vehicle.

'70 - '77 Maverick; '71 - '72 Comet.

..... C0DF-19A779A ..... ea..... 2.95

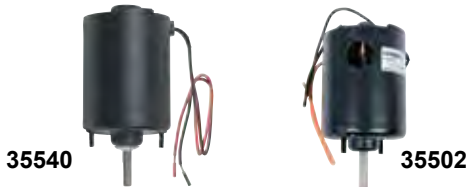

**35540**

**35502**

**HEATER / AIR CONDITIONING BLOWER MOTORS**

'70 Without A/C.  
2 wires ..... 35540 ..... ea..... 44.95

'71 - '77 Without A/C.  
2 wires.  
 ..... 35502 ..... ea..... 39.95



**FM9033**

**FM9032AL**

**HEATER CORES**

Aluminum.

'70 - '77 Without A/C.  
 ..... FM9033 ..... ea..... 57.50  
With A/C.  
 ..... FM9032AL ..... ea..... 39.95



**UNIVERSAL MECHANICAL OIL PRESSURE GAUGE**

BY SUNPRO®

2" mechanical-type gauge with 12 volt internal lighting. Features a black face and ranges from 1-100 PSI. Includes the gauge, tubing, adapters and mounting hardware.

..... CP7982 ..... kit..... 22.95



**UNIVERSAL MECHANICAL OIL / WATER TEMPERATURE GAUGE**

BY SUNPRO®

2" mechanical-type gauge with 12 volt internal lighting. Features a black face and ranges from 100-280° Fahrenheit. Includes gauge, 72" capillary with 1/2" NTP thread, and mounting hardware.

..... CP7983 ..... kit..... 22.95



**OIL / WATER GAUGES**

BY AUTO METER

Universal 2 1/16" oil pressure and temperature gauges with white faces. Oil ranges from 0-100 PSI and water ranges from 130°-280° F. Illuminated by incandescent bulb and around-the-dial lighting. Includes custom red and green bulb covers; 6' tubing; 10' nylon tubing with 1/8" NPT fittings; and 1/4", 3/8" and 1/2" NPT adapter / fittings.

..... 2323 ..... ea..... 59.95



**UNIVERSAL OIL / VOLTAGE / WATER GAUGE KIT BY SUNPRO®**

This Customline™ triple gauge kit

features 2", black face oil pressure, voltmeter and water / oil temperature gauge set within a chrome bezel with removable panel. Kit includes tubing (6'), 1/8" and 1/4" NTP pressure adapters, 1/2" NTP temperature fitting, mounting hardware and instructions. Voltmeter hook-up wire not included. 12-volt internal lighting.

Designed for vehicles with 12-volt negative ground systems.

**NOTE:** Electrical parts are non-returnable once installed. We will replace defective units only ..... CP7996 ..... kit..... 49.95

**Can't decide on a gift idea?**

**How about an Auto Krafters Gift Certificate?**  
They are available in your choice of dollar amount.  
Check online or ask your sales associate today.

**BF** Boxing Fee    **OS** Oversize    **TF** Truck Freight



**OIL / WATER / VOLTAGE GAUGE SET**

BY AUTO METER®



This universal three-gauge set features 2 1/16" white face oil pressure, volt and water temperature gauges. Oil ranges from 0 to 100 PSI, voltage ranges from 10 to 16 volt, and water ranges from 100° to 280° F. Illuminated by incandescent bulb and includes custom red and green bulb covers. Also included are 6 ft. capillary tubing; 10 ft. nylon tubing, 1/8" NPT fittings; and 1/4", 3/8", and 1/2" NPT adapters / fittings. Includes mounting bracket and instructions.

..... 2327 .....ea ..... 79.95



**UNIVERSAL OIL / VOLTAGE / WATER GAUGE KIT**

BY BOSCH®

This StyleLine™ mechanical triple-gauge kit features 1 1/2", oil pressure, voltmeter and water / oil temperature gauges. Kit includes tubing (6 ft.), 1/8" and 1/4" NPT pressure adapters, 1/2" NPT temperature fittings, mounting hardware and instructions. Volt meter hookup wire not included. Also features black-painted bezel and 12-volt internal lighting.

Designed for vehicles with 12-volt negative ground systems.

**NOTE:** Electrical parts are non-returnable once installed. We will replace defective units only.

Chrome bezel, white faces ..... FST8208 .....kit ..... 49.95



FZ88R



SST802R



SUN802R60

**3 3/8" RETRO TACHOMETERS BY BOSCH®**

These tachometers with black faces reproduce period styling with modern electronics inside. Features include:

- internal settings for 1-, 2-, 4-, 6-, 8- and 10-cylinder engines
- all-metal housing with removable chrome cup
- brackets for mounting either to steering column or dash
- vibration-proof air core meter design
- 360° lighting for better night visibility

Great item to finish your restoration project.

**NOTE:** All electrical parts are non-returnable once installed. We will replace defective units only.

'60s style ..... FZ88R ..... ea ..... 189.95  
'70s style ..... SST802R ..... ea ..... 199.95

**Wiring Harness for Above Tachometers**

Includes terminal ends..... SUN802R60.....ea ..... 24.95



CP7906

FST7903

**BOSCH® SPORT II™ TACHOMETERS**

Works on 6- or 8-cylinder 12 volt engines. Reads to 8,000 RPM. The air core meter returns to zero when ignition is on, and it has internal illumination.

2 5/8" Black face..... CP7906 ..... ea ..... 55.00  
White face ..... CP7904 ..... ea ..... 49.95  
3 3/8" Black face..... CP7901 ..... ea ..... 69.95  
**NEW** White face..... FST7903 ..... ea ..... 69.95

**\*\* For tachometer wiring harnesses, see page 25. \*\***

**Dash-Area Components**



**DASH COVER**



Covers your worn or damaged dash Made from molded black ABS plastic. Includes silicone adhesive to attach to original pad.

**NOTE:** There is a \$10.00 boxing fee for this item.

'70 - '77 ..... AC405 ..... ea ..... 139.95



**GLOVE BOX DOOR BUMPERS**

'73 - '77

..... AV4246 ..... pr ..... 1.00

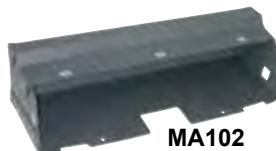

MA102

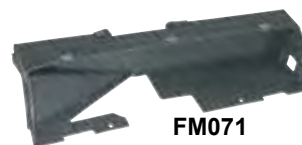

FM071

**GLOVE BOX LINERS**

'74 - '77 Without A/C.

..... MA102 ..... ea ..... 22.95

With A/C.

..... FM071 ..... ea ..... 22.95



**RADIO KNOB**

Chrome-plated plastic.

'74 - '77 Maverick; '74 Comet AM / FM with monaural; '75 - '77 Comet all.

..... D3AZ-18817A ..... ea ..... 7.95

**\*\* For radios and related, see pages 18-20. \*\***

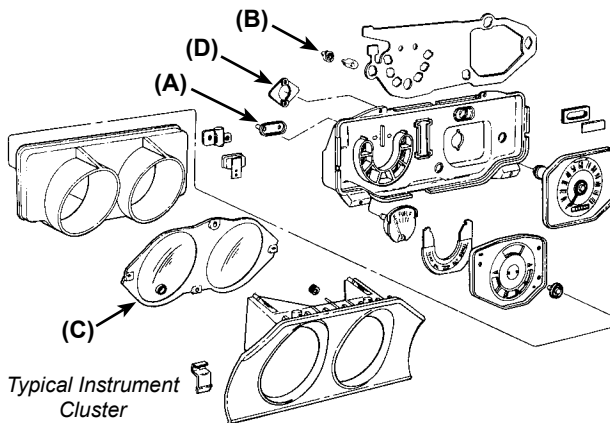

Typical Instrument Cluster



**GAUGE MOUNTING STUD INSULATOR (A)**

Plastic.

'70 - '73

..... C9ZZ-10C914A ..... ea ..... 4.95



**INSTRUMENT CLUSTER / DASH WARNING LAMP BULBS - REPLACEMENTS**



Fits many Ford and Mercury applications and are sometimes used in multiple lights. Replaces industry #194 bulb. Package of 2 bulbs.

..... C2AZ-13466C ..... pr ..... 4.95



Boxing Fee



Oversize



Truck Freight





**C8OZ-13711A      AK3969**

**INSTRUMENT CLUSTER LIGHT BULB SOCKET (B)**  
SEE DIAGRAM ON PREVIOUS PAGE

**Reproduction**

'70 - '77 ..... C8OZ-13711A ..... ea ..... 2.95

**Replacement**

Single contact with a 12" lead, miniature base and fits a 5/8" hole  
 ..... AK3969 ..... ea ..... 4.95



**INSTRUMENT PANEL LENS (C)**  
SEE DIAGRAM ON PREVIOUS PAGE

'70 - '77 ..... D0DZ-10887 ..... ea ..... 39.95



**SPEEDOMETER HEAD GASKET (D)**  
SEE DIAGRAM ON PREVIOUS PAGE  
Rubber.

'70 - '77 Maverick; '74 - '77 Comet.  
 ..... C9MY-17303A ..... ea ..... 6.95

66" Long ..... **400310**

80" Long ..... **400270**

63" Long ..... **CA3021**

**SPEEDOMETER CABLES**

'70 - '75 '70 - '72 Maverick 6-cylinder with A/T and speed control (lower);  
'73 Maverick 6-cylinder with A/T, speed control, and EGR (lower);  
'73 - '74 Maverick 6-cylinder with speed control (lower);  
'71 - '73 Comet 6-cylinder with A/T and speed control (lower);  
'75 Comet with A/T and speed control (lower).  
Approximately 66" long.  
 ..... 400310 ..... ea ..... 29.95

'70 - '75 Maverick A/T without speed control; '73 - '74 Comet without speed control.  
Approximately 80" long.  
 ..... 400270 ..... ea ..... 29.95

'70 - '77 '70 - '77 Maverick 3-speed; '70 - '77 Maverick A/T without speed control; '76 - '77 Comet A/T without speed control.  
Approximately 63" long.  
 ..... CA3021 ..... ea ..... 29.95



**SPEEDOMETER CABLE CLIP**  
Attaches the speedometer cable to the transmission housing.

'70 - '77 ..... B9TZ-17264R ..... ea ..... 5.95



**C5ZZ-17285A**



**C2DZ-17271-17**



**C0DZ-17271A**

**SPEEDOMETER GEARS**

**Drive Gears**

LH tilt. 1 3/8" I.D., 1 1/16" O.D., 1 1/16" thick.

6 teeth. Pink.  
 ..... C5ZZ-17285A ..... ea ..... 19.95

7 teeth. Black.  
 ..... C4DZ-17285A ..... ea ..... 19.95

**Driven Gears**

**LH Tilt**

White (color may not be correct).

16 teeth ..... C2DZ-17271-16 ..... ea ..... 9.95

17 teeth ..... C2DZ-17271-17 ..... ea ..... 9.95

18 teeth ..... C2DZ-17271-18 ..... ea ..... 9.95

19 teeth ..... C2DZ-17271-19 ..... ea ..... 9.95

20 teeth ..... C2DZ-17271-20 ..... ea ..... 9.95

21 teeth ..... C2DZ-17271-21 ..... ea ..... 9.95

**RH Tilt**

16 teeth Burgundy.  
 ..... C0DZ-17271A ..... ea ..... 9.95

17 teeth White.  
 ..... C3DZ-17271C ..... ea ..... 9.95

18 teeth Yellow.  
 ..... C0DD-17271B ..... ea ..... 9.95

19 teeth White.  
 ..... C0DZ-17271B ..... ea ..... 9.95

20 teeth Black.  
 ..... C1DZ-17271A ..... ea ..... 9.95



**SPEEDOMETER DRIVEN GEAR RETAINER CLIP**  
C-type clip.

'70 - '77 ..... C1DZ-17292A ..... ea ..... 3.95



**1130**



**GRT1150**



**1170**

**GRANT® SIGNATURE SERIES STEERING WHEELS**  
Universal.

**Collector's Edition**

**Leather Grip**

Polished aluminum spokes with genuine leather grip. Dish size: 3 3/4". Includes styling sleeve.

3-spoke 14" diameter.  
 ..... 1130 ..... ea ..... 219.95

4-spoke 14" diameter.  
 ..... GRT1150 ..... ea ..... 249.95

**Mahogany Grip**

Polished aluminum spokes with mahogany grip. Dish size: 3". Includes styling sleeve.

3-spoke 14" diameter.  
Dish size: 3" ..... 1170 ..... ea ..... 269.00  
Dish size: 3 1/2" ..... 1175 ..... ea ..... 309.95

**GRANT® SIGNATURE SERIES STEERING WHEELS CONTINUED**



**GT**

3-spoke with silver anodized aluminum spokes. Dish size: 3". Includes styling sleeve.

- Rally style with black grip.  
13" diameter ..... 760 ..... ea ..... 139.95
- Mahogany grip.  
14" diameter ..... 714 ..... ea ..... 209.95



**Elite GT**

Features hand-stitched leather-grained grip. Dish size: 3¾". Includes styling sleeve.

- 3-spoke 14" diameter.  
..... 739 ..... ea ..... 189.95
- 4-spoke 14" diameter.  
..... 742 ..... ea ..... 179.95



**Le Mans**

Highly polished aluminum spokes with black rim. Dish size: 3¾". Includes styling sleeve.

- 4-spoke, 14" diameter.  
..... GRT1070 ..... ea ..... 229.95



**GRANT® CLASSIC SERIES STEERING WHEEL**

Chrome-plated cold-rolled steel spokes with genuine hardwood grip with walnut finish and anodized aluminum rivets. 3-spoke.

- 13½" diameter, 3¾" dish.  
..... 213 ..... ea ..... 179.95
- 15" diameter, 4⅛" dish.  
..... 201 ..... ea ..... 169.95



5665



5875

**GRANT® FORD LOGO HORN BUTTONS**

Made of billet aluminum and features the Ford logo. For Grant steering wheels only.

**Signature Series Horn Buttons**

For use with Signature Series steering wheels only.

- Black plastic ..... 5665 ..... ea ..... 34.95
- Billet aluminum ..... 5875 ..... ea ..... 59.95

**Classic Series Horn Button**

For use with Classic Series steering wheels only.

- Chrome ..... 5685 ..... ea ..... 19.95



GRT52491

**GRANT® SIGNATURE SERIES BILLET ALUMINUM STEERING WHEEL INSTALLATION KITS**

Necessary for installation of Grant Signature Series steering wheels. Includes instructions.

- '70 - '77 Black luster.  
**NOTE:** This kit will disable factory cruise.  
..... 3249 ..... kit ..... 34.95
- Polished aluminum.  
..... GRT52491 ..... kit ..... 74.95

**AFTERMARKET STEERING WHEEL KITS**



STW100S6



STW101S6

**Woodgrain Grip**

15" diameter, 2" deep, 6-hole hub mount. Features a real walnut wood grip.

- '70 - '77 Slotted three-spoke design, high-quality chrome center with horn button and chrome bubble ring with a blue Ford oval emblem.  
Black powder-coated hub.  
..... STW100S6 ..... kit ..... 269.95
- Anodized billet aluminum hub.  
..... STW101S6 ..... kit ..... 269.95



STW110S9



STW112S9

**Black Leather Grip**

14" diameter, 2" deep, 9-hole hub mount. Features a premium leather grip, polished aluminum center, anodized billet aluminum hub, and black horn cap with a blue Ford oval emblem.

- '70 - '77 3-hole 3-spoke.  
..... STW110S9 ..... kit ..... 269.95
- Slotted 4-spoke.  
..... STW112S9 ..... kit ..... 269.95



**STEERING WHEEL - REPRODUCTION**

2-spoke wheel with horn bars. Pad sold separately (see next page).

- '70 - '74 '70 Maverick with locking column; '71 - '72 Maverick with Deluxe interior; '73 - '74 Maverick without leather-covered rim; '71 - '74 Comet.  
..... D2AZ-3600K-01 ..... ea ..... 299.95



**STEERING WHEEL MOUNTING NUT**

Correct style lock nut for mounting the wheel to the column shaft. 5/8" - 18. 15/16" hex. Grade 5, cadmium plated.

'70 - '77  
 ⚙️ ..... 382412-S ..... ea ..... 4.95



**STEERING WHEEL / HARMONIC BALANCER PULLER KIT**



When removing steering wheels and harmonic balancers, this 13-piece kit is what you need. Drop-forged, heat-treated steel. Alloy steel center shaft with floating, removable swivel applies even pressure, preventing damage.

Kit includes (1) yoke, (1) threaded shaft, (1) floating swivel, (2) 5/16" x 4" (7.9 mm x 101 mm) bolts, (2) 1/4" x 3" (6.3 mm x 76 mm) bolts, (3) 1/4" x 2" (6.3 mm x 50 mm) bolts, (3) 5/16" x 2" (7.9 mm x 50 mm) bolts and a durable blow-molded plastic case

Manufacturer's warranty against defects in materials and workmanship for a period of one year from the date of original retail purchase.

..... KRA100 ..... kit ..... 29.95

**STEERING WHEEL CENTER PAD, HORN PADS, AND TRIM PLATE - 2-SPOKE**



**Steering Wheel Center Pad**

Black with original grain texture. Made in the USA.

'70 - '74 With locking column.  
 ⚙️ ..... D0AZ-3623A ..... ea ..... 59.95

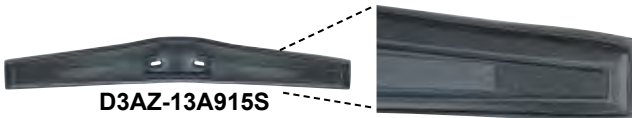

D3AZ-13A915S

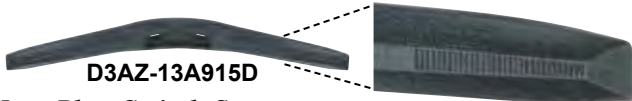

D3AZ-13A915D

**Horn Blow Switch Covers**

Black vinyl. Does not include emblem.

'70 Maverick with standard interior and locking column.  
 ..... D3AZ-13A915S ..... ea ..... 39.95

'70 - '74 Maverick; '71 - '72 Comet. All with Deluxe interior, wood-grain trim plate on wheel and locking column.  
 ⚙️ ..... D3AZ-13A915D ..... ea ..... 39.95

'72 - '74 Maverick with standard interior and locking column.  
 ..... D3AZ-13A915S ..... ea ..... 39.95



**Horn Pad**

Molded in black with Ford oval in the center.

'75 - '77 With 2-spoke steering wheel.  
 ..... D9TZ-13A805A ..... ea ..... 99.95



**Horn Blow Switch Trim Plate**

For 2-spoke Deluxe steering wheel with woodgrain trim plate.

'70 - '74 Maverick; '71 - '72 Comet.  
 ⚙️ ..... D1ZZ-13932 ..... ea ..... 39.95



**Horn Blow Switch Assembly**

'70 - '74 With 2-spoke steering wheel (standard or Deluxe) and locking column.  
 ⚙️ ..... D2AZ-13A875 ..... ea ..... 99.95

**RIM-BLOW HORN PADS, INSERTS, AND SWITCH COVERS - 3-SPOKE**



D0OZ-3623D

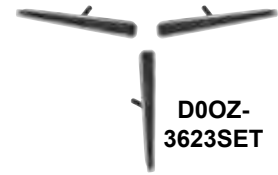

D0OZ-3623SET

**Pads and Inserts**

Original grain and texture. Emblems not included. Black only; must dye for other colors.

'70 - '74 Maverick; '71 - '72 Comet; all with 3-spoke rim-blow steering wheel.

**Pad**

For the aluminum and plastic insert set, see part # D0OZ-3623SET (below).

⚙️ ..... D0OZ-3623D ..... ea ..... 69.95

**Insert Set**

6-piece aluminum and plastic insert set.

⚙️ ..... D0OZ-3623SET ..... set ..... 79.95



**Horn Blow Switch Cover**

Paintable black plastic. Fits into a groove at the bottom of 3-spoke steering wheels and covers the gap between the ends of the rim blow horn switch.

'70 - '74 Maverick and '71 - '72 Comet.

⚙️ ..... D1AZ-13875C ..... ea ..... 12.95



**Rim-Blow Horn Switch**

**NOTE:** This unit is tested OK before being packaged for sale. There is no warranty and no returns will be accepted.

'70 - '74 Maverick with 3-spoke steering wheel; '70 - '72 Comet with 3-spoke steering wheel.

⚙️ ..... D1AZ-13A875A ..... ea ..... 119.95



C7AZ-13305



D3TZ-13305B

**TURN SIGNAL LEVERS**

Chrome.

'70 - '77 Chrome knob.  
 ⚙️ ..... C7AZ-13305 ..... ea ..... 9.95

Black knob.  
 ⚙️ ..... D3TZ-13305B ..... ea ..... 9.95

**Column Shifter-Related Parts**



D3OZ-7213A



E3SZ-7213A

**SHIFT LEVER KNOBS**

'70 - '76 Maverick A/T with column shift; '71 - '72 Comet A/T with column shift.

Chrome ..... D3OZ-7213A ..... ea ..... 16.95

'76 - '77 Maverick with column shift.  
 Black plastic ..... E3SZ-7213A ..... ea ..... 12.95

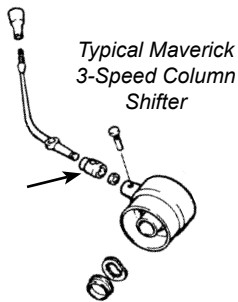

**SHIFT LEVER INSULATORS**

'70	Column-shift A/T ....	B8S-7246A	ea.....	4.95
'70 - '72	Column-shift C4 A/T.			
		1M-7246A	ea.....	6.95
'70 - '77	3-speed M/T			
		C2OZ-7246A	ea.....	6.95
'71 - '77	Column-shift C4 A/T.			
		C2OZ-7246A	ea.....	6.95

**TRANSMISSION CONTROL SELECTOR INDICATOR**

'70 - '77 Maverick with fixed steering column; Comet with fixed steering column and column shift.



**UPPER STEERING COLUMN BEARING**

3/4" I.D., 1 3/16" O.D., 1/4" thick.

'70 - '77 Maverick; '72 Comet with fixed wheel.

	F23Z-3517B	ea.....	22.95
--	------------	---------	-------

**UPPER STEERING COLUMN BEARING SLEEVE**

1 3/16" I.D., 1 5/16" O.D., 3/8" thick. 8 ribs on outside.

'70 - '77	E2AZ-3518C	ea.....	6.95
-----------	------------	---------	------



**BRAKE PEDAL PADS**

'70	Maverick.			
	M/T	C5ZZ-2457G	ea.....	3.95
'71	Maverick; Comet with drum brakes.			
	M/T.			
		C5ZZ-2457G	ea.....	3.95
	A/T.			
		C6OZ-2457A	ea.....	6.95
'72	M/T.			
		C5ZZ-2457G	ea.....	3.95
	A/T after 4/3/72.			
		C6OZ-2457A	ea.....	6.95
'73 - '75	With drum brakes.			
	M/T	C5ZZ-2457G	ea.....	3.95
	A/T	C6OZ-2457A	ea.....	6.95
'74 - '75	With disc brakes before 12/16/74.			
	M/T	C5ZZ-2454D	ea.....	9.95
	A/T	D3ZZ-2454A	ea.....	9.95
'75	With disc brakes after 12/16/74.			
	M/T	C5ZZ-2457G	ea.....	3.95
	A/T	C6OZ-2457A	ea.....	6.95
'76 - '77	M/T	C5ZZ-2457G	ea.....	3.95
	A/T	C6OZ-2457A	ea.....	6.95



**BRAKE PEDAL PAD TRIM**

'72 - '77	M/T.			
		D1ZZ-2A487B	ea.....	14.95
	A/T.			
		C6OZ-2A487A	ea.....	13.95



**BRAKE PEDAL PAD AND TRIM**

Includes brake pedal pad with "DISC BRAKE" emblem in the middle and outer trim piece.

For individual parts, see numbers D3ZZ-2454A (previous column) and C6OZ-2A487A (above).

'74 - '75	A/T with disc brake before 12/16/74.			
		D3ZZ-2454/2A487A	ea.....	19.95



**C5ZZ-7A624B**



**C5ZZ-7B544A**

**CLUTCH PEDAL PAD AND TRIM**

'70 - '77	Pad.			
		C5ZZ-7A624B	ea.....	3.95
	Trim.			
		C5ZZ-7B544A	ea.....	6.95



**C8SZ-2454B**



**C8SZ-2A798A**

**PARKING BRAKE PEDAL PAD AND TRIM**

'75	Pad	C8SZ-2454B	ea.....	6.95
	Trim	C8SZ-2A798A	ea.....	9.95



**HEADLAMP DIMMER SWITCH CAP**

Rubber.

'70 - '73		C5ZZ-13533A	ea.....	5.95
-----------	--	-------------	---------	------

\*\* For dimmer switch, see page 25. \*\*

**Radios and Related**

**NOTE:** Electrical parts are not returnable once installed. We will replace defective units only.



**AM / FM RADIO WITH AUXILIARY HOOKUP**



Custom-made to fit the radio bezel.

This 200 watt (4 x 50) unit features:

- auxiliary input for iPod, Sirius XM or MP3
- 30 station presets (12 AM, 18 FM)
- digital clock
- seek / auto tune
- 4-way fader
- electronic tuner
- 4-channel RCA pre-outs

Includes a chrome nose piece.

2-year limited manufacturer's warranty. You must retain invoice to verify purchase date.

**NOTE:** This radio does not include a cassette player.

'70 - '73	Maverick; '71 - '73 Comet. All with factory under-dash, hang-on radio. Will not fit vehicles with in-dash radios.			
		RAD230MV	ea.....	199.95



**HIDEAWAY RADIO**

Fits in any vehicle. The Secretaudio SST-V is a hidden system that offers great flexibility for mounting in any type of vehicle. The main receiver is usually hidden under the seat, behind the dash or in the trunk. A 10' cord from the

tuner / amp plugs into an LCD display. Can be operated from up to 40' away with the included radio frequency remote.

This 200 watt AM / FM CD controller features:

- USB input for control of MP3 / WMA flash drive
- iPod and iPhone input
- direct CD changer control (CD changer sold separately; see part # CD1PLAYER – next column)
- LCD flush-mount trim bezel with LCD swivel-mount bracket
- 24 station pre-sets
- auxiliary audio input
- alpha-numeric LCD display shows artist and song title for USB, iPod and satellite radio
- satellite-ready via RCA auxiliary input for dock-and-play satellite tuners or streaming via Bluetooth
- and many more features

Ideal for street rods, customs and classic vehicles.

..... SST3 ..... ea ..... 299.95



**HB-221-5575**



**HB-121-5575**

**“HERMOSA” AM / FM RADIOS**

Features:

- AM / FM tuner
- rear-mounted USB port allows playing of MP3 / WMA music files through your system using up to a 32GB flash drive (enough space for up to 7,000 songs)
- rear-mounted auxiliary inputs for portable devices
- white or green illumination—customize to fit to your vehicle's interior
- built-in 25 watts x 4 channel RMS amplifier, providing plenty of power to your speakers
- dual RCA pre-outs let you add external amplifiers
- built-in Bluetooth® wireless connectivity—safely make hands-free calls through your audio system or stream music from any smart phone

Uses Retro's patented InfiniMount adjustable shaft system, making installation easy in virtually any classic vehicle. Features black bezel and push-buttons, and chrome knobs.

**NOTE:** Shipped as modular components; some assembly is required.

'74 – '77 Black face.  
 ..... HB-221-5575 ..... ea ..... 302.49  
 Chrome face.  
 ..... HB-121-5575 ..... ea ..... 302.49

**SCP-07**



**SCP-08**

**RADIO SCREEN PROTECTORS**

Features the Ford logo and a vintage-look radio dial, giving your Retro-Sound® radio an added sense of authenticity. Applies without adhesive (similar to cell phone screen protectors), so they are simple to apply and easy to remove. Package of 3.

“Hermosa” radio.  
 Early style.  
 ..... SCP-07 ..... pkg ..... 20.95  
 Late style.  
 ..... SCP-08 ..... pkg ..... 20.95



**LCB-221-5575**



**LCB-121-5575**



**“LONG BEACH” AM / FM RADIOS**

Made-For-iPod® / iPhone®, and features built-in Bluetooth® connectivity for hands-free phone calls and wireless audio streaming. It also features:

- 32,000-color display to customize the radio to your vehicle's interior
- 2 USB ports for iPod® / iPhone® music playing, plus 2 standard auxiliary inputs
- built-in 25 watts x 4 channel power RMS MOSFET amplifier, as well as front and rear RCA pre-outs, plus subwoofer output, to add external amplifiers
- AM / FM RDS tuner with 30 presets

Mounts seamlessly into your dash, with no additional face plates or bezels needed. Features chrome bezel and knobs, and black push-buttons.

**NOTE:** Shipped as modular components; some assembly is required.

The Long beach is SiriusXM-Ready™ and connects to the SiriusXM™ SXV300 Connect Vehicle Tuner (sold separately, subscription required), which plugs directly into the Long beach without the need for special adapters or cables. Compact and installs easily and discreetly behind the dash for a fully-integrated look. Ask your sales person for more information about the SXV300.

'74 – '77 Black face.  
 ..... LCB-221-5575 ..... ea ..... 417.99  
 Chrome face.  
 ..... LCB-121-5575 ..... ea ..... 417.99

**\*\* For reproduction radio knob, see page 14. \*\***



**AMPLIFIED AM / FM HIDE-AWAY ANTENNA**



A great solution for anyone who doesn't want to install a standard fender-mount antenna.

Installs in seconds using a standard antenna plug and your radio's power antenna wire. Uses magnetic field circuitry for enhanced radio reception. Can be installed almost anywhere, thanks to the supplied 105" antenna lead and power wire.

..... HPA1 ..... ea ..... 24.95



**1-DISC CD / DVD PLAYER**



New slim-size half DIN CD / DVD player. This single-disc player can be operated from the buttons on the Hideaway Radio (part # SST3, see previous column). Plays CD / CD-R / CD-RW / DVD audio / WMA / MP3. Small enough to hide under the seat or in the glove box.

Features:

- ESP electronic shock protection
- repeat / program / random / intro function
- multi-angle playback
- last position memory

Includes 9' cable for connection to CAM head unit. Measures 7" W x 1" H x 6 3/4" D. .... CD1PLAYER ..... ea ..... 169.00

**Auto Krafter's catalogs are now available online in PDF format!**

**Just visit our website at [www.autokrafter.com](http://www.autokrafter.com)**





**UNDERCOVER II SPEAKERS**



Designed specifically for under-seat or horizontal "wall" installations. Features one 8" woofer and 2 Piezo tweeters in an enclosure that measures 3" high x 11 wide x 12½" long. 200 watt capacity. Offers a full, deep sound.

**NOTE:** This is an oversize item; additional shipping charges apply.  
 ..... UNDERCOVER2 .....pr ..... 159.95

**PACKAGE TRAY RADIO SPEAKER AND GRILLE**



**Speaker**

Dual-cone, 25 watts, 4 ohms speaker measuring 6" x 9" with a mounting depth of 3". Although not original in all cars, can be used as a universal rear speaker in cars with rear package tray. Pigtail wire included.

'70 - '71 Maverick; '71 Comet.  
 ..... C9AZ-18808R ..... ea ..... 29.95



**Grille**

Exact reproduction featuring the correct screen pattern. Can be used as a universal piece for all cars with a rear package tray. Mounting hardware included.

'70 - '77 Maverick; '71 - '72 Comet.  
 ..... D4AZ-18978R ..... ea ..... 49.95



**INTERIOR REAR-VIEW MIRRORS AND BRACKETS**

Universal aftermarket replacement. Day / nite. Glues to windshield. Comes complete with bracket #76990. Adhesive not included.

10" ..... MIR-17 ..... ea ..... 24.95  
 12" ..... 33000 ..... ea ..... 24.95

**Bracket for Above Mirrors**

Metal. Included with rear-view mirror #s MIR-17 and 33000.  
 ..... 76990 ..... ea ..... 3.95



**REAR-VIEW MIRROR ADHESIVE**

This 2-part application permanently remounts mirrors to windshields. Achieves handling strength in seconds. Mirror mounting strength in 15 minutes. Bonds metal and plastic buttons.

0.04 oz. .... 110672 ..... ea ..... 3.25

**Removable Consoles**



**BC-SHORTY™ CONSOLE**

Made to fit on the seat and installs with a nylon strap under the seat attaching to the front of the console. Comes with two drink holders, storage compartment and arm rest. Covered with black vinyl upholstery.

13" long, 7½" high, 11" wide at cup holders, 8" wide at the storage area.  
 '70 - '77 Fits most cars with early bench seat.  
 ..... BCSHORTY-01 ..... ea ..... 119.95

**Console Vinyl Colors**

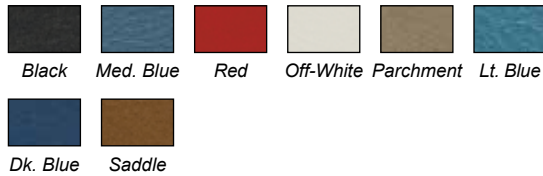

**HH6473CP-03**

Installs in seconds over the carpeted hump between 2 bucket seats and is held in place with Velcro® - no tools needed. Features a storage compartment and 2 drink holders. This is a must for going to the shows, just remove the Hump-Hugger to restore to the original look. No more spilled drinks, and additional storage, too.

21" long, 10½" tall, 8½" wide at cupholders, 7½" wide at storage compartment.

Available in the following colors:

- Black (01)
- Medium Blue (02)
- Red (03)
- Off-White (05)
- Parchment (06)
- Light Blue (07)
- Dark Blue (08)
- Saddle (10)

Please add color code to the end of the part number when ordering.

'70 - '77 ..... HH6473CP- ..... ea ..... 139.95



**BD-DRINKSTER™ CONSOLE**



Made to fit the contour of your bench seat and fastens with a strap under the seat to the front of the console. Includes 2 drink holders, storage compartment and arm rest. Console is covered with vinyl upholstery.

**BDDR-06**

16" long, 7" high, 8" wide at cup holders, 7" wide at storage area.

Available in the following colors:

- Black (01)
- Medium Blue (02)
- Red (03)
- Parchment (06)
- Saddle (10)

Please add color code to the end of the part number when ordering.

With narrow bench seat.

..... BDDR- ..... ea ..... 109.95



**HHLR-02**

**"LOW RIDER" CONSOLE**

Made to fit over most transmission humps in front of bench seats. Features include two king-size drink holders and a storage area that will accommodate sunglasses, street maps, etc. Two aluminum plates can be easily adjusted to fit your transmission hump and can be removed if not needed.

17" long, 5" high, 11" wide at drink holders, 8" wide at the storage area.

Available in the following colors:

- Black (01)
- Medium Blue (02)
- Red (03)
- Parchment (06)
- Saddle (10)

Please add color code to the end of the part number when ordering.

'70 - '77 Fits most cars with bench seat.  
 ..... HHLR- ..... ea ..... 139.95

**Floor Shifter-Related Parts**



**3-SPEED FLOOR SHIFTER BOOT**

Covers openings up to 3½" x 4½". Includes retainer plate.

..... 6283 ..... ea ..... 19.95

**BF** Boxing Fee    **OS** Oversize    **TF** Truck Freight



**HURST® INDY SHIFTER  
3-SPEED FLOOR SHIFTER**

This 3-speed floor shifter comes with everything you need to convert your 3-speed column shift to floor shift, or replace your old worn-out floor shifter. Shift lever, boot, hardware, and instructions included.

Does not include trim plate. For boot and trim plate package, see part number KY1148429 below.

'70 - '77 ..... 5010002 ..... ea ..... 279.95



**Shift Boot and Plate**

Covers holes up to 3½" x 4½". For use with shifter kit #5010002 above.

NEW ..... KY1148429 ..... ea ..... 38.95



**HURST® T-HANDLE  
SHIFT KNOB**

Universal. Chrome with the Hurst logo on top. Includes adapter and jam nut.

..... 1530032 ..... ea ..... 44.95

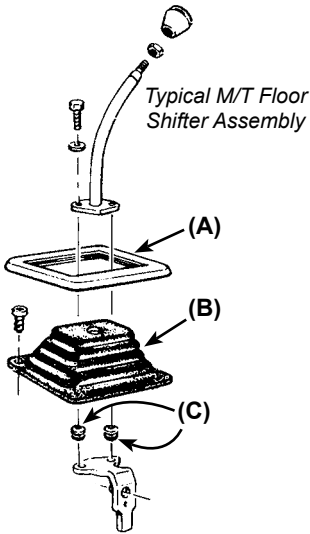

Typical M/T Floor Shifter Assembly

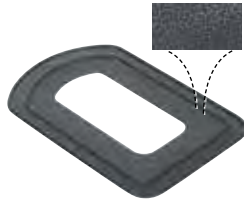

D1DZ-7262A

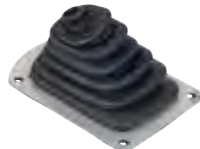

D1DZ-7277A



379998-SK



**FLOOR SHIFTER BOOT TRIM BEZEL (A)**

Black textured plastic with raised ribs. Sits on top of shifter boot for a clean factory look. Measures 5¾" wide x 7¾" at longest point.

'71 - '76 M/T. .... D1DZ-7262A ..... ea ..... 22.95

**FLOOR SHIFTER BOOT (B)**

Accordion-style black rubber shift boot with retainer. Measures 4½" x 6¾" at the base.

'70 - '77 Maverick M/T; '71 - '77 Comet M/T. .... D1DZ-7277A ..... ea ..... 29.95

**GEAR SHIFT LEVER MOUNTING GROMMETS (C)**

These rubber grommets insulate the lever to mounting plate bolts for shifter repair. Requires 1 pair per vehicle.

'73 - '76 8-cylinder with Ford 4-speed M/T. .... 379998-SK ..... pr ..... 6.95

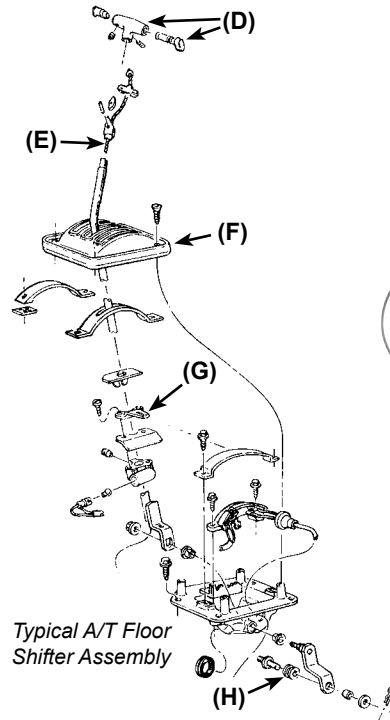

Typical A/T Floor Shifter Assembly



D3OZ-7213B

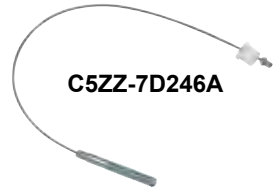

C5ZZ-7D246A

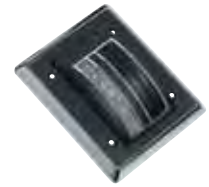

D5FZ-7D443B

**AUTOMATIC TRANSMISSION T-HANDLE SHIFT KNOB (D)**

Chrome. Includes nut.

'71 - '77 Floor-shift A/T. .... D3OZ-7213B ..... ea ..... 28.95

**TRANSMISSION SHIFTER SELECTOR CABLE (E)**

'71 - '74 Floor-shift A/T ..... C5ZZ-7D246A ..... ea ..... 19.95

**A/T TRANSMISSION SELECTOR BEZEL WITH DIAL (F)**

Black Corinthian grain finish bezel with chrome border. Includes dial.

'75 - '76 C4 with floor shifter. .... D5FZ-7D443B ..... ea ..... 34.95

**A/T TRANSMISSION CONTROL  
SELECTOR INDICATOR (G)**

'71 - '74 C4 with console shifter. .... C9ZZ-7A110A ..... ea ..... 9.95

**A/T SHIFT ROD INSULATOR (H)**

'70 - '77 all with A/T. .... C7SZ-7341B ..... ea ..... 5.95

**B&M STARSHIFTER®**  
In normal mode, the StarShifter® is a straight-line detent shifter. In Low, the trigger can be lifted and the stick pulled back to convert to ratchet action. Move the stick forward for the 1-2 and 2-3 shifts.

Dimensions: 12.22" L x 12.12" H x 6.25" W. Base can be trimmed to fit any floor. Cable operated for quick installation and accurate shifting. Reverse lockout feature meets NHRA and IHRA requirements.

Includes neutral safety switch, transmission brackets and levers, and a 5' shift cable.

**NOTE:** This is a universal part; some modification may be necessary.

C4 or C6. .... KY80675 ..... ea ..... 239.95

**Can't decide on a gift idea?**

**How about an Auto Krafters Gift Certificate?  
They are available in your choice of dollar amount.  
Check online or ask your sales associate today.**



**B&M® UNIMATIC A/T SHIFTER**



Universal. Ideal for replacing a column shifter with a floor shifter. Will work with almost all 2-, 3-, or 4-speed automatic transmissions. By using a cable to connect the shifter to the transmission instead of a rod, it allows you to mount the shifter almost anywhere on the floor.

Kit includes shift lever assembly, 5-foot shifter cable, rubber boot and chrome trim plate, black T-handle, neutral safety switch, and hardware.

Does not include backup light switch. Shift lever length is 12.72".

..... KY80775 ..... kit ..... 199.95



**B&M® SPORT A/T SHIFTER**



Universal. Designed with a detent mechanism. Features neutral safety switch, back-up light switch, lighted gear indicator and a plastic base (can be trimmed for custom fit). Also includes plastic shift handle, aluminum stick lever, base plate, boot, shift assembly parts, cable, mounting hardware, and instructions.

C4, C6 or AOD ..... KY80776 ..... ea ..... 249.95



**Bracket and Lever Kit for AOD**

Required for installation of Sport Shifter #KY80776 on Ford vehicles with AOD-type transmission. Kit includes lever, cable bracket, spacers, swivel end, cotter pin, and bolts.

AOD ..... KY40496 ..... kit ..... 87.95



**UNIVERSAL FLOOR SHIFT CONVERSION KIT**

Includes an 11" chrome plated stick, black shift knob (3/8" - 24 thread), shift boot and bezel, linkage and mounting hardware (zinc plated). Also includes installation instructions.

**NOTE:** Will not work with front-wheel drive or transaxle. With A/T (C/M or F/M/2).

..... 7668 ..... kit ..... 129.95

**Door-Area Components**

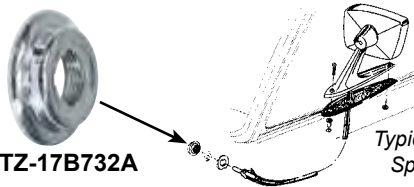

**C9TZ-17B732A**

*Typical Remote Sport Mirror*

**REMOTE CONTROL SPORT MIRROR BEZEL NUT**

'70 - '72 Maverick; '72 Comet. Each with remote control sport mirror. .... C9TZ-17B732A ..... ea ..... 24.95

**C0AB-7021478**

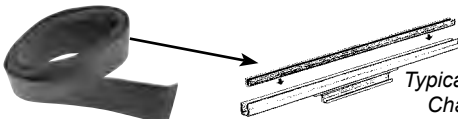

*Typical Glass Channel*

**DOOR GLASS CHANNEL TAPE**

This rubber tape is 1 1/2" wide x 4' long. Use in lift channel or surround trim channels in the door glass, vent glass, and quarter glass.

3/4" thick ..... 8A-7021478 ..... ea ..... 9.95  
 1/16" thick ..... C0AB-7021478 ..... ea ..... 7.95

**NOTE:** While we take great care to present the colors as true as possible to the actual color, their accuracy is not guaranteed, due to the limitations of the printing process.



**D1DZ-6223201A**



**D1DZ-6223200A**



**WINDOW REGULATORS**

OE-correct look and fitment, heavy metal construction with black painted finish. Includes bolts and lock washers.

'70 - '74 2-door.  
 LH. .... D1DZ-6223201A ..... ea ..... 159.95  
 RH. .... D1DZ-6223200A ..... ea ..... 159.95



**C8AZ-6223342A**



**C9UZ-8223342A**



**C8AZ-6223342SETBLK**



**D2OZ-6523342A**



**D3AZ-6523342**



**D3AZ-6523342B**

**WINDOW REGULATOR HANDLES**

'70 Before 7/21/69.  
 Does not include knob. Not exact OE in appearance, but will work.  
 Without knob ..... C8AZ-6223342A ..... ea ..... 12.95  
 With black knob ..... C8AZ-6223342SETBLK. ea ..... 15.95  
 '70 - '72 Maverick 2-door sedan from 7/21/69 to 10/1/71; '71 - '72 Comet 2-door sedan before 10/1/71.  
 ..... C9UZ-8223342A ..... ea ..... 14.95  
 '72 After 10/1/71.  
 Includes knob, screw cover, and screw.  
 ..... D2OZ-6523342A ..... ea ..... 24.95  
 '73 - '77 Includes knob.  
 Clear knob ..... D3AZ-6523342 ..... ea ..... 9.95  
 Black knob ..... D3AZ-6523342B ..... ea ..... 14.95



**C8AZ-6523352C**

Clear Ivy Gold Parch. Vermilion White  
 Dk. Blue Maroon Ginger Green

**WINDOW REGULATOR HANDLE KNOBS**

Knobs only. Handles are sold separately.

'70 - '72 Black ..... C8AZ-6523352C ..... ea ..... 5.95  
 Clear ..... C8AZ-6223352CL ..... ea ..... 8.95  
 Ivy gold ..... C8AZ-6223352IG ..... ea ..... 8.95  
 Parchment ..... C8AZ-6223352PR ..... ea ..... 9.95  
 Vermilion ..... C8AZ-6223352VE ..... ea ..... 9.95  
 White ..... D1AZ-6523352D ..... ea ..... 7.95  
 Dark blue ..... D1AZ-6523352E ..... ea ..... 8.95  
 Maroon ..... D1AZ-6523352F ..... ea ..... 7.95  
 Ginger ..... D1AZ-6523352G ..... ea ..... 8.95  
 Green ..... D1AZ-6523352H ..... ea ..... 7.95





**WINDOW REGULATOR HANDLE SCREW COVER**

Aluminum. Not included with handles.

'70 - '73 ..... C8AZ-6223362A ..... ea ..... 1.50

**C8AZ-6223370A**



**C9ZZ-6523370A**

**WINDOW REGULATOR HANDLE BACK-UP PLATES (ESCUTCHEONS)**

Plastic. Fits between the window regulator handle and the door panel.

'70  
Maverick.  
Semi-opaque white . C8AZ-6223370A ..... ea ..... 1.50  
Bright finish. Import.  
..... C9ZZ-6523370A ..... ea ..... 7.95

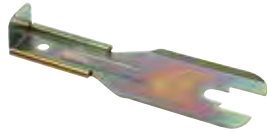

**WINDOW REGULATOR HANDLE REMOVAL TOOL**

Removes any door handle or window regulator clip instantly. Just insert the tool and push the clip out. One-piece metal construction.

..... 701-895 ..... ea ..... 5.95

**D1AZ-6522601**



**D1AZ-6522600**



**DOOR HANDLES**

Chrome plated.

'70 - '72  
Maverick; '71 - '72 Comet.  
LH.  
..... D1AZ-6522601 ..... ea ..... 14.95  
RH.  
..... D1AZ-6522600 ..... ea ..... 14.95



**D0DZ-6221999**



**DLG1999**



**C5DZ-6221999C**

**DOOR LOCK GROMMETS**

'70 - '71  
Stainless steel with felt inner ring.  
..... D0DZ-6221999 ..... pr ..... 9.95  
'71 - '77  
Clear plastic.  
..... DLG1999 ..... pr ..... 1.25  
Chrome-plated plastic.  
..... C5DZ-6221999C ..... pr ..... 4.95



**C8AZ-6221850**



**D5TZ-1021850A**



**75407**



**D5OZ-6521850B**

**DOOR LOCK KNOBS**

'70 - '77  
'70 - '77 Maverick and '71 - '72 Comet.  
Chrome.  
..... C8AZ-6221850 ..... pr ..... 5.95  
'73 - '77  
Octagonal head. 1 1/2" long.  
**Black**  
Without grommet .... D5TZ-1021850A ..... ea ..... 4.95  
With grommets ..... 75407 ..... pr ..... 5.95  
**Chrome Mylar® covered**  
Without grommet .... D5OZ-6521850B ..... ea ..... 4.95



**C2AZ-6223030A**



**C7AZ-54265A28**

**DOOR BUMPERS**

'70 - '72  
Upper. Requires 2 per vehicle.  
..... C2AZ-6223030A ..... ea ..... 1.00  
'70 - '77  
Requires 4 ..... C7AZ-54265A28 ..... ea ..... 1.00



**C9AZ-6221813A**



**C9AZ-6221812A**



**AK400**



**C5AZ-6221952A**

**DOOR LATCHES**

Has a 1 1/4" long lock rod shaft with 2 holes in it.

'70 - '72  
LH.  
..... C9AZ-6221813A ..... ea ..... 59.95  
RH.  
..... C9AZ-6221812A ..... ea ..... 59.95

**DOOR LATCH SCREWS**

Set of 3 screws.

'70 - '72 ..... AK400 ..... set ..... 2.50

**DOOR LATCH ROD RETAINER**

'70 - '77 ..... C5AZ-6221952A ..... ea ..... 6.95

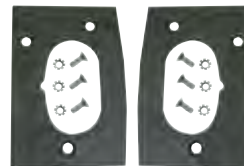

**DOOR LATCH-AREA REPAIR PLATES**

Used to repair fatigue stress cracks around door latches.

'70 - '77  
..... 6722008R ..... pr ..... 29.95



**C5AZ-6222008A**



**AK560**

**DOOR STRIKER PLATE AND SCREWS**

**Plate**

Includes screws.

'70 - '77  
'70 - '77 Maverick; '71 - '72 Comet.  
..... C5AZ-6222008A ..... ea ..... 15.95

**Screws**

Set of 4.

'70 - '77  
Zinc plated.  
..... AK560 ..... set ..... 3.00  
Stainless steel.  
..... AK562 ..... set ..... 3.00



**DOOR HINGE PIN**

Requires 1 per hinge. Must trim to fit.

'70 - '77 ..... AV14559 ..... ea ..... 1.95



**DOOR HINGE PIN BUSHING**

'70 - '77 requires 2 per hinge.

..... AV14550 ..... ea ..... 1.25

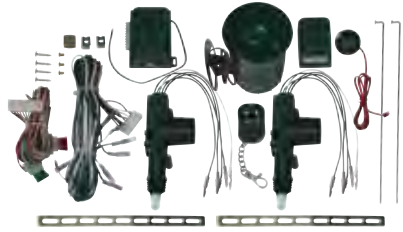

**POWER DOOR LOCK KIT WITH ALARM**

Converts a 2-door manual lock system to a power lock system. Includes actuators, all wiring, mounting hardware, remotes, alarm, detailed wiring diagram, and instructions on how to install parts and how to program the long-range remote. CA2000.....kit.....249.95



C7AZ-6222053A



C7AZ-6343562A

**KEY BLANKS**

- '70 - '77 Ignition / doors..... C7AZ-6222053A ..... ea..... 2.50
- '70 - '77 Trunk / glove box.... C7AZ-6343562A ..... ea..... 2.50



LCK23



LCK3



LCK4



LCK25

**LOCK SETS**

**Door Lock Cylinders and Keys**

- '70 - '77 ..... LCK23..... set..... 19.95

**Ignition and Door Lock Sets**

- '70 - '73 '70 - '73 Maverick; '71 - '73 Comet.  
..... LCK3..... set..... 29.95
- '73 - '75 ..... LCK4..... set..... 34.95
- '76 - '77 After 2/76.  
..... LCK25..... set..... 39.95



SW814



SW1114



SW1191



LCK47



US70L

**Ignition Cylinder and Key Assemblies**

- '70 6-cylinder without locking column.  
Reproduction..... SW814 ..... ea..... 12.95
- '70 - '73 With locking column before 5/73.  
..... SW1114 ..... ea..... 19.95
- '73 - '76 From 5/14/73 to 2/2/76.  
..... SW1191 ..... ea..... 19.95
- '76 - '77 After 2/2/76.  
..... LCK47 ..... ea..... 14.95
- '76 - '77 ..... US70L..... ea..... 14.95



**STEERING COLUMN LOCK ACTUATOR ASSEMBLY**

Genuine Ford.

- '73 - '77 Maverick with fixed wheel; '74 - '77 Comet after 6/3/74.  
..... D4AZ-3E723A..... ea..... 79.50



**POWER REMOTE TRUNK LATCH RELEASE KIT**

Has the classic look of the remote cable-style release with a modern electric solenoid function.

Designed to be simple to install. Very little, if any, modifications to the car is needed. Includes all the necessary parts and installation instructions.

- '70 - '72 Maverick; '71 - '72 Comet.  
..... C7AZ-6243200EL ..... kit ..... 109.95

Without Map Lamps

With Map Lamps

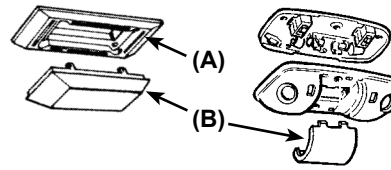

C6OZ-13783A



D1AZ-13783B



D2LY-13783R

**DOME LAMP LENSES (A)**

- '70 - '71 Before 6/1/71.  
For bezel, see part number D0AZ-13788A (below).  
**NOTE:** This lens will fit only the D0AZ-13788A bezel.  
..... C6OZ-13783A..... ea..... 9.95
- '70 - '71 Before 6/1/71.  
For bezel, see part number D0AZ-13788DC (below).  
**NOTE:** This lens will fit only the D0AZ-13788DC bezel.  
..... C6OZ-13783DC ..... ea..... 9.95
- '71 - '77 Maverick after 6/1/71 without map lamps; '71 - '76 Comet without dome map lamps.  
..... D1AZ-13783B ..... ea..... 9.95
- '74 - '77 Maverick with dome map lamps.  
..... D2LY-13783R ..... ea..... 9.95



D0AZ-13788A



D6UZ-13788A

**DOME LAMP BEZELS (B)**

- '70 - '71 Before 6/1/71.  
For lens, see part # C6OZ-13783A (above).  
**NOTE:** This bezel will fit only the C6OZ-13783A lens.  
..... D0AZ-13788A ..... ea..... 15.95
- '70 - '71 Before 6/1/71.  
For lens, see part # C6OZ-13783DC (above).  
**NOTE:** This bezel will fit only the C6OZ-13783DC lens.  
..... D0AZ-13788DC ..... ea..... 15.95
- '71 - '77 Maverick; Comet after 6/1/71 without dome map lamps.  
..... D6UZ-13788A ..... ea..... 19.95



**LED DOME LAMP / COURTESY LAMP BULB**

High-power Rigid LED 12 volt white bulb. 650 lumens, 1.5 watt. 100% brighter than stock bulb.

- '71 - '77 With 561 "loop"-style bulb.  
..... LED-561..... ea..... 6.95



**C8AZ-6229024**



**C8AZ-6229232A**



**AV2713**

**COAT HOOK RELATED**

'70 - '77	<b>Cover</b>	Must be installed over retainer #C8AZ-6229232A (below).
	C8AZ-6229024	ea ..... 5.95
	<b>Retainer</b>	
	C8AZ-6229232A	ea ..... 4.95
	<b>Screw</b>	
	AV2713	ea ..... 25

**PACKAGE TRAYS**

Fits between the rear seat and back glass. Black only. Must be painted for other colors.

**NOTE:** There is a \$10.00 per order boxing fee for these items.



**FM113-01**



**FM114-01**

**Sturdy Fiberboard**

'70 - '77	2-door without speakers.	
	FM113-01	ea ..... 39.95
	2-door with speakers.	
	FM114-01	ea ..... 49.95



**FM115-01**



**FM116-01**

**Mesh Covered**

'70 - '77	2-door without speakers.	
	FM115-01	ea ..... 59.95
	2-door with speakers.	
	FM116-01	ea ..... 59.95



**FAM2DRMV**

**PACKAGE TRAY INSULATION**

Jute insulation.

'70 - '77	2-door.	
	FAM2DRMV	ea ..... 14.95
'71 - '77	4-door.	
	FAM4DRMV	ea ..... 12.95

**Interior Wiring / Electrical**

**NOTE:** Electrical parts are non-returnable once installed. We will replace defective units only.

**NOTE:** We have available a limited number of NOS switches not listed in our catalogs. Please call if you do not find listed the switch you need.



**TACHOMETER WIRING HARNESS**

'70	C9OZ-17A299A	ea ..... 39.95
'72	C9OZ-17A299A	ea ..... 39.95

**\*\* For tachometers, see page 14. \*\***



**SW1054**



**SW1054WH**



**SW992A**

**IGNITION SWITCHES**

'70	Without locking column.	
	Switch only	SW1054 ..... ea ..... 24.95
	Pigtail only	SW1054WH ..... ea ..... 19.95
'70 - '77	'70 6-cylinder from 10/1/68 with locking column; '71 - '77 all. Stock for '71 - '77, but will work for '70 by cutting the plug from your old switch and splicing it to the new switch.	
	SW992A	ea ..... 39.95



**IGNITION SWITCH BEZEL**

Screw-on type.

Early '70 6-cylinder without locking column.	C9ZZ-11584	ea ..... 19.95
--	------------	----------------



**HEADLAMP SWITCH**

Import.

'70 - '77 Maverick; '71 - '77 Comet.	D3ZZ-11654A	ea ..... 24.95
--------------------------------------	-------------	----------------



**SW263**



**68-3211**

**HEADLAMP DIMMER SWITCH AND PLUG**

'70 - '77	Switch.	
	SW263	ea ..... 6.95
	Plug.	
	68-3211	ea ..... 3.50

**\*\* For dimmer switch cap, see page 18. \*\***



**SW896**



**D1ZZ-17A553A**

**WINDSHIELD WIPER / WASHER SWITCHES**

'70 - '72	Without intermittent wipers.	
	Replacement	SW896 ..... ea ..... 69.95
'73 - '77	Without intermittent wipers.	
	7 terminals	D1ZZ-17A553A ..... ea ..... 39.95

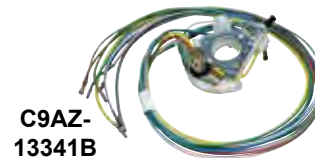

**C9AZ-13341B**



**D2AZ-13341C**

**TURN SIGNAL SWITCHES**

'70	Without locking steering column.	
	C9AZ-13341B	ea ..... 89.95
'70	With locking steering column.	
	D2AZ-13341C	ea ..... 119.95
'71 - '72	D2AZ-13341C	ea ..... 119.95
'73 - '77	Maverick; Comet before 4/5/76.	
	D6DZ-13341B	ea ..... 79.95



**Boxing Fee**



**Oversize**



**Truck Freight**



**TURN SIGNAL SWITCH WIRING TERMINAL END**

Fits Ford and Mercury cars and trucks. Electrical wire terminal end with retention barb, .084" diameter

**NEW**

pin, 20-14 gauge.

..... AK18856 ..... ea ..... 89



**SM16**

**SM19**

**TURN SIGNAL CAM REPAIR KITS**

'70 - '77 '70 - '72 Maverick; '71 - '77 Comet.  
 ..... SM16 ..... kit ..... 19.95  
 '73 - '77 ..... SM19 ..... kit ..... 14.95

**EMERGENCY WARNING INDICATOR FLASHER RELAYS**



**Replacement**

12 volts, 2 terminals. Made in the USA.

'70 - '77  
 ..... SF552B ..... ea ..... 3.50



**Switch Relay for LED Lights and Bulbs**

12 volts, 20 amp maximum, with 2 terminals and reverse polarity base.

'70 - '77  
 ..... 90652 ..... ea ..... 19.95

**NEW**

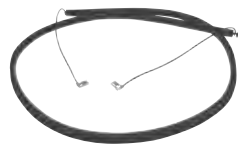

**RIM BLOW HORN SWITCH**

**NOTE:** This unit is tested OK before being packaged for sale. There is no warranty and no returns will be accepted.

'70 - '74 Maverick with 3-spoke steering wheel; '70 - '72 Comet with 3-spoke steering wheel.  
 ..... D1AZ-13A875A ..... ea ..... 119.95



**HORN BLOW SWITCH ASSEMBLY**

'70 - '74 With 2-spoke steering wheel (standard or Deluxe) and locking column.  
 ..... D2AZ-13A875 ..... ea ..... 99.95



**BACK-UP LAMP SWITCH**

New old stock.

'70 C4 with locking column.  
 ..... D0DZ-15520CNOS ..... ea ..... 49.95



**DOME LAMP SWITCHES (DOOR JAMB)**

'70 - '76 '70 Maverick LH (without locking column) or RH front door and door;  
 '71 - '75 Maverick RH (without auto seat back latch) front door;  
 '71 - '72 Comet RH front door;  
 '73 - '76 Comet LH or RH front door (with 2-pin terminal).  
 ..... C8AZ-13713C ..... ea ..... 6.95



**DS174**



**SW2003A**

**DOME LAMP SWITCHES (DOOR JAMB) CONTINUED**

'70 - '76 '70 Maverick LH front door (with locking column);  
 '71 - '72 Maverick LH front door;  
 '73 - '75 Maverick LH front door (without auto seat back latch);  
 '73 - '75 Maverick LH and RH front door (with auto seat back latch);  
 '71 - '72 Comet LH front door;  
 '73 - '76 Comet LH or RH front door (with 3 terminals).  
 ..... DS174 ..... ea ..... 22.95  
 '76 - '77 ..... SW2003A ..... ea ..... 10.95



**BRAKE LAMP (STOP LAMP) SWITCH**

'70 - '77  
 ..... SW881 ..... ea ..... 15.95



**CLAMP-ON DASH SWITCH - ON / OFF / ON**

Universal. Can be clamped onto the under-dash flange of most vehicles. Includes bracket and bolt for easy installation. Heavy-duty construction. Features 3 terminals and a chrome toggle with three positions: ON-OFF-ON. Can be used for fog lamps, wiper motor, emergency flashers, etc.

..... S1206 ..... ea ..... 15.95

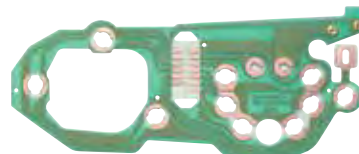

**INSTRUMENT CLUSTER CIRCUIT BOARD**

Reproduction printed circuit board with 13 wires on circuit plug.

'70 - '73 ..... D0DZ-10K843A ..... ea ..... 109.95

**NEW**



**INSTRUMENT CLUSTER VOLTAGE REGULATOR**

This new, electronic voltage regulator is more accurate and does not need adjustment like the original mechanical regulators. Fits on the back of the instrument panel.

'70 - '77 ..... C9AZ-10804AADJ ..... ea ..... 28.95



**SOLDERLESS WIRE TERMINAL / CONNECTOR KIT**

Contains an assortment of the 18 most popular solderless, insulated terminals and connectors. Comes in a plastic display box with dividers. Includes 9" crimping tool. 175 pieces.

..... TK50413A ..... kit ..... 19.95



**AUTO KRAFTERS, INC. GOLD CARD CLUB**

- Save 10% on our already low prices\*
- Get expedited order shipping
- \$14.95 flat shipping on orders\*

**JOIN THE AUTO KRAFTERS GOLD CARD CLUB TODAY!**

Ask your salesperson for more information!

\*Some exclusions apply.

Trunk

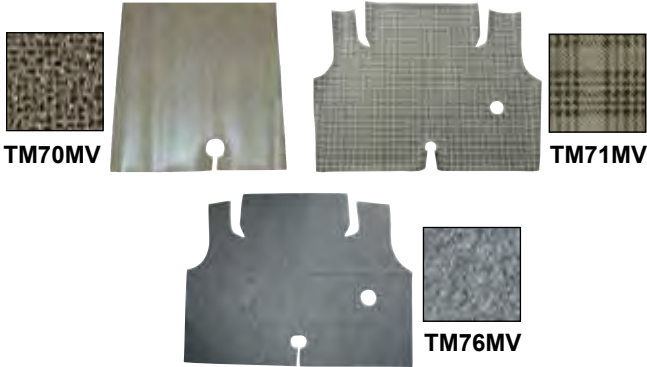

TRUNK MATS

Manufactured from original materials in the correct patterns, styles, and colors. Die-cut for a perfect fit. Meets or exceeds OEM specifications.

**NOTE:** When test-fitting mats, please use a sheet or some other barrier between the mat and the trunk floor. Mats with soiled backing cannot be returned.

'70	Speckled vinyl	..... TM70MV	.....ea	..... 62.95
'71 - '75	Plaid vinyl.			
		..... TM71MV	.....ea	..... 72.95
'76 - '77	Gray felt.			
		..... TM76MV	.....ea	..... 49.95



**Heavyweight Rubberized Vinyl**

Splatter pattern. Made in the USA.

'70	Light gray.			
		..... TM70MVSPR	.....ea	..... 54.95
'71 - '75	Gray.			
		..... TM71MVSPR	.....ea	..... 54.95

**FATMAT® RATTLE TRAP SOUND DEADENER – 50 SQ. FT.**  
 Bulk roll – 50 sq. ft. (33½' x 18") x 80 mil thick. Features aggressive adhesive backing that can be installed at almost any temperature. Requires no heat to install and is great for exterior noise reduction, insulation, and improving sound system quality. Includes installation kit (containing roller and instruction sheet). Manufacturer's lifetime warranty.....RATPAK50.....ea ..... 159.95

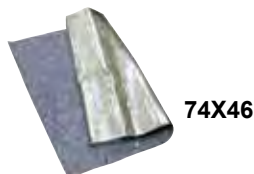

**HEAT SHIELD AND SOUND DEADENER**

This quality insulation uses space-age technology to keep heat and noise out of the driving and listening environment. Consists of one sheet of 99.5% pure industrial-grade aluminum laminated to ¾" padding, achieving the highest deflection of heat and muting of sound when placed with the aluminum side toward the heat and / or noise source.

74" x 48"		..... 74X46	.....ea	..... 62.95
-----------	--	-------------	---------	-------------

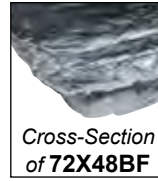

Cross-Section of 72X48BF

**INSULATOR AND SOUND DEADENER WITH BUBBLE FILM**

This reflective foil insulation consists of 2 layers of polyethylene bubble film sandwiched between two layers of 99.9% pure aluminum foil, making it 5/16" thick. Temperature range from 60° F to 180° F. Works great for insulating headliners, floor pans, trunk area, door panels, kick panels, etc. Cut and form into needed shapes using scissors and apply with contact cement or weatherstrip adhesive.

72" x 48"		..... 72X48BF	.....ea	..... 29.95
-----------	--	---------------	---------	-------------

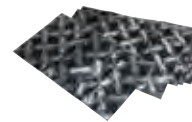

**DYNAMAT® EXTREME HEAT SHIELD AND SOUND DEADENER**

This thermo-acoustic control material will give you a cool, quiet ride. Eliminates road noise and engine noise, giving your vehicle a new feel. Applied to the sheet metal surrounding your speakers, it eliminates speaker distortion, vibration, rattles and squeaks. Easy peel-and-stick application for doors, floor, roof and trunk. Contains 9 sheets which add up to a total of 36 sq. ft. of material. For installation rollers, see part #10007 or #10005 below.

		..... 20455	.....ea	..... 199.95
--	--	-------------	---------	--------------



**DYNAMAT® EXTREME INSTALLATION ROLLERS**

Helps achieve the strongest bond possible when applying Dynamat®.

Wood	1 1/8"	..... 10005	.....ea	..... 14.95
Rubber	2"	..... 10007	.....ea	..... 24.95

**TRIM ADHESIVE**

Recommended for installation of carpet, headliners, upper quarter trim panels, hood insulation, trunk mats, etc. Also recommended for repair of sunvisors or anywhere you need a good adhesive.

16 oz. aerosol	..... 82019	.....ea	..... 10.95
----------------	-------------	---------	-------------

**MISTY® HEAVY-DUTY TRIM ADHESIVE**

Can be used on a variety of surfaces, uneven or porous, for temporary or permanent bonding. The wide web spray pattern dries clear and is waterproof and non-staining. Contains no chlorinated solvents and is ozone non-depleting.

**Caution:** Please read all directions carefully. This adhesive is extremely flammable and harmful if swallowed. Eye irritant. Please keep away from children. Made in the USA.

12 oz. aerosol	..... A00315	.....ea	..... 9.95
----------------	--------------	---------	------------



TDB70MAV TDB72MAV

**TRUNK DIVIDER BOARDS**

Thin, paper-like material. Excellent reproduction.

'70 - '77		..... TDB70MAV	.....ea	..... 19.95
'72 - '77	With Luxury Decor Option.			
		..... TDB72MAV	.....ea	..... 39.95



**TRUNK DIVIDER INSULATION**

Jute material. 60" x 25".

'73 Comet 2-door sedan.  
 F205 .....ea ..... 12.95



**SPARE TIRE COVER**

Plaid.

**NOTE:** Does not match plaid trunk mat.

'71 - '75  
 TCR.....ea ..... 51.95



**SPARE TIRE MOUNTING NUT**

'70 - '77

C8AZ-1462B .....ea ..... 4.95



**C5AZ-6243200A**

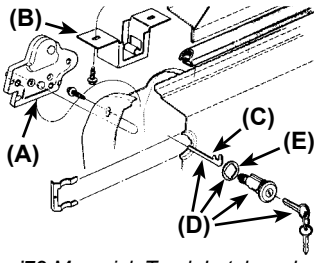

'72 Maverick Trunk Latch and Lock Assembly



**D0DZ-6543252A**



**D0OZ-6343283B**

**TRUNK LATCH (A)**

'70 - '72 ..... C5AZ-6243200A .....ea ..... 39.95

**TRUNK LATCH STRIKER PLATE (B)**

'70 - '77 ..... D0DZ-6543252A .....ea ..... 14.95

**TRUNK LOCK EXTENSION ROD (C)**

Universal. Cut to fit.

'70 - '77 ..... D0OZ-6343283B .....ea ..... 3.95



**LCK18**



**C7AZ-6243625**

**TRUNK LOCK SET (D)**

Contains 1 lock cylinder, 2 keys, 1 cylinder pad, and 1 aftermarket retainer.

**NOTE:** Must reuse OE retainer.

'70 - '77 ..... LCK18 .....set ..... 19.95

**TRUNK LOCK CYLINDER GASKET (E)**

'70 - '77 ..... C7AZ-6243625 .....ea ..... 1.50



**OE-STYLE POWER REMOTE TRUNK LATCH RELEASE KIT**

Classic look of a cable-style remote release with a modern electric solenoid function. Simple installation—few, if any, modifications to the car are needed. Includes all the necessary parts and installation instructions.

'70 - '72 Maverick; '71 - '72 Comet.  
 C7AZ-6243200EL .....kit ..... 109.95



**FUEL FILLER PIPE-TO-TRUNK FLOOR SEAL**

'71 - '77

D1ZZ-9008 .....ea ..... 28.95



**TRUNK FLOOR PLUG**

Rubber. Fits 3/4" hole. 2 1/4" wide.

'71 - '73 ..... 383796S .....ea ..... 2.95



**TRUNK / ENGINE LAMP KIT**

This dome-shaped cover with bulb included comes with wire and is an exact copy of the original Ford kit. For engine compartment and / or trunk.

'70 - '72 ..... C2RZ-15A700A .....kit ..... 29.95

**Exterior**



**HOOD LATCH**

Reproduction hook-type hood latch with a corrosion-resistant black finish.

'70 - '77 ..... D1DZ-16700A .....ea ..... 74.95



**HOOD PROP ROD**

Universal fit. Has a polished finish and made of quality 304 stainless steel. Includes stainless washers and spring and has a tip cover to protect the hood. Overall rod length is 35" but may be cut to desired length.

C5ZZ-16826S .....ea ..... 39.95

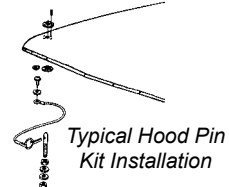

**HOOD PIN KIT**

Deluxe aftermarket kit with lanyards. Includes: pins, cables, latching pins, backing plates, nuts, washers and screws. Genuine Ford.

'70 - '77 ..... M-16700A .....kit ..... 59.95



**HOOD HINGES**

Quality reproductions.

'70 - '77 '70 - '77 Maverick; '71 - '77 Comet.  
 D0DZ-167967PR .....pr ..... 149.95



**C7AZ-16758ASET**



**380478S**

**HOOD BUMPERS**

- '70 - '77 Hood to fender. Set of 4. Push-on type.
  - ⌘ ..... C7AZ-16758ASET .....set..... 8.95
- '70 - '77 Hood to cowl. Requires 2 per vehicle. Includes screw ..... 380478S .....ea ..... 1.95



**HOOD INSULATION**

- '70 - '77 ⌘ ..... D2DZ-16738A .....ea ..... 49.95

\*\*\* For Hood, see page 35. \*\*\*  
 \*\*\* For Hood Scoop, see page 36. \*\*\*

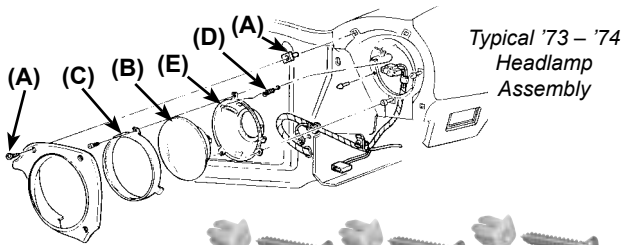

**AK1014**

**HEADLAMP DOOR MOUNTING KIT (A)**

- Contains 6 stainless steel screws and 6 nylon nuts.
- '70 - '77 ⌘ ..... AK1014 .....kit..... 4.00

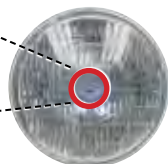

**C0DZ-13007A**

**HEADLAMP BULB - HIGH / LOW BEAM (B)**

**Reproduction - Halogen**

Round, 7" sealed-beam bulb. Features a reversed, raised FoMoCo oval logo in the center like the original.

- '70 - '72 Maverick before 1/3/72; '71 - '72 Comet before 1/3/72.
  - ⌘ ..... C0DZ-13007A .....ea ..... 24.95

**Aftermarket - LED**

Round, 7" sealed-beam LED replacement headlamp by Grote®. 2D1 DOT approved for all 7" (Par 56) systems and can be used for passenger cars, commercial vehicles and motorcycles. Features die-cast aluminum housing, UV-protected polycarbonate lens, voltage range of 9 - 32 volts (allows for use in 12-volt systems), and includes a 3-pin H4 connector kit for easy installation.



- ⌘ ..... 90941-5 .....ea ..... 229.95



**11A-13015A**



**AK294**

**HEADLAMP BULB RETAINER RING AND RETAINING SCREWS**

**Ring (C)**

- Round.
  - '70 - '77 ⌘ ..... 11A-13015A .....ea ..... 9.95

**Screws**

These stainless steel screws hold the headlight bulb retaining ring to the adjusting bucket. Set of (6) #8 - 18 x 7/16" Phillips head screws (replaces Ford part number 375452-S).

- '70 **NEW** ..... AK294 .....set..... 3.75



**HEADLAMP SOCKET AND PIGTAIL**

Universal. Fits most 3-terminal sealed-beam headlamps.

- ..... 85810 .....ea ..... 3.50



**C6AZ-13031R**



**D5UZ-13031A**

**HEADLAMP SPRINGS (D)**

- '70 ..... C6AZ-13031R .....ea ..... 2.95
- '75 - '77 Genuine Ford.
  - ⌘ ..... D5UZ-13031A .....ea ..... 8.95



**HEADLAMP ADJUST KIT**

Includes 2 adjusting screws and nuts, 4 attaching screws, and 1 spring. Enough to do 1 headlamp.

- '70 - '74 Maverick; '73 - '74 Comet.
  - ⌘ ..... AK413 .....kit..... 8.95



**C9TZ-13119A**



**C9TZ-13118B**

**HEADLAMP BULB MOUNTING AND ADJUSTMENT BUCKETS (E)**

- '70 - '74 LH.
  - ⌘ ..... C9TZ-13118B .....ea ..... 24.95
- RH.
  - ⌘ ..... C9TZ-13119A .....ea ..... 24.95



**WINDSHIELD WIPER BLADE - REPLACEMENT**

- 16". Requires 2 per car.
  - '70 - '77 '70 - '77 Maverick; '71 Comet.
    - ⌘ ..... C3OZ-17528L .....ea ..... 19.95



**WINDSHIELD WIPER ARM**

- Reproduction. Made like original. Polished finish.
  - '70 - '77 ⌘ ..... C6ZZ-17526 .....ea ..... 19.95

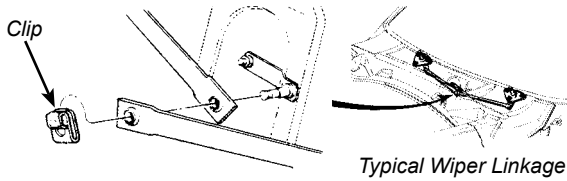

Typical Wiper Linkage



**WINDSHIELD WIPER ARM LINKAGE CLIP**

'70 - '77  
 C5ZZ-17531A .....ea ..... 2.95



**D0DZ**  
Detail



**D1ZZ**  
Detail



**D0DZ-18813A**



**D1ZZ-18813**



**D3DZ**  
Detail



**E3AZ**  
Detail



**D3DZ-18813A**



**E3AZ-18813A**

**RADIO ANTENNAS**

'70 - '72 Excellent reproduction. Has a teardrop telescoping mast that looks like the original, with base and cable attached. Includes base cover, pad, screws and clips, and fender hole template. Cable is approximately 82" long with a 90° end. Mast is not removable.  
 ..... D0DZ-18813A .....ea ..... 89.95

'71 - '72 Square base. Round telescoping mast.  
 ..... D1ZZ-18813 .....ea ..... 79.95

'73 - '77 Excellent reproduction. 29%<sup>8</sup>/<sub>16</sub>" straight, round mast that looks like the original. Cable (approximately 82" long with 90° end) is attached to the base. Mast is removable. Includes base cover, pad, screws, clips, and fender hole template.  
 ..... D3DZ-18813A .....ea ..... 89.95

**NEW**  
 '73 - '77 Square base. Manual. 1 piece. Replacement. Genuine Ford ..... E3AZ-18813A .....ea ..... 49.95

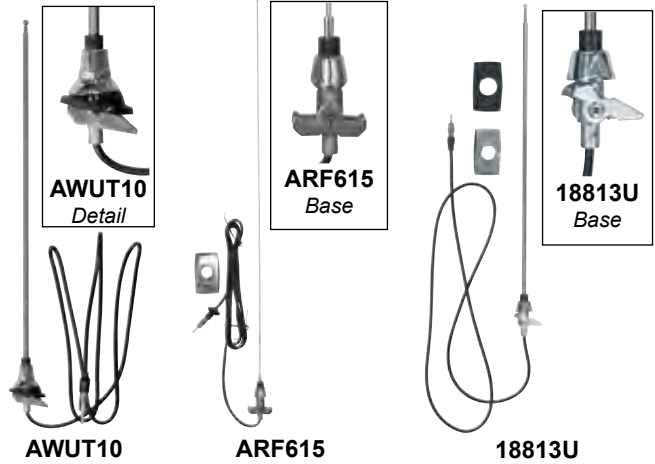

**RADIO ANTENNAS - UNIVERSAL REPLACEMENT**

Designed for either AM or FM bands. Will work for most vehicles.

**Round Base**

3-section retractable mast is stainless steel and measures 38" long. The base covers 1" hole and includes a dome cap and nut. The attached cable measures 48". Includes instructions for easy installation.

..... AWUT10 .....ea ..... 14.95

**Rectangular Base**

**Non-retractable Mast**

Cable is approximately 72" long. Please measure your cable length; some applications may require an extension. Not exactly as original.

..... ARF615 .....kit ..... 16.95

**Retractable Mast**

43" long 3-section retractable mast. Base measures 2 1/2" x 1 1/4" and includes chrome-plated retaining nut. Cable is approximately 51" long.

..... 18813U .....kit ..... 24.95



**D1DZ-17682A**



**D0DZ-17682D**

**RACING-STYLE EXTERIOR SIDE-VIEW SPORT MIRRORS**

Excellent reproduction. Includes pad and mounting hardware.

'70 - '77 Maverick; '71 - '77 Comet.  
 LH remote.  
 ..... D1DZ-17682A .....ea ..... 169.95

RH non-remote (matches LH remote).  
 ..... D0DZ-17682D .....ea ..... 184.95



**EXTERIOR DOOR HANDLE PAD SET**

Set of 4 pads. Requires 1 set for 2-door, 2 sets for 4-door.

'70 - '77 Maverick; '71 - '72 Comet.  
 ..... 67HP .....set ..... 4.95

**NOTE: We have marked with a  those parts which also fit corresponding Mercury models, such as Comet.**





**C7ZZ-6522404-5P**

**EXTERIOR DOOR HANDLES**

Includes buttons, pads, and hardware.

- '70 - '77   Maverick; '71 - '77 Comet.  
**Concours-quality reproduction.** Includes buttons, pads, pivot mechanisms, rod clips, and hardware. These are the finest handles on the market.  
 ..... C7ZZ-6522404-5P .....pr ..... 57.50  
 Import.  
 ..... 6722404 .....pr ..... 34.95



**C7AZ-6243625**



**C5AZ-6222023A**

**DOOR LOCK CYLINDER GASKET**

- '70 - '77    ..... C7AZ-6243625 .....ea ..... 1.50

**DOOR LOCK CYLINDER RETAINER**

- '70 - '77   Maverick; '71 - '72 Comet.  
 ..... C5AZ-6222023A .....ea ..... 2.00

**DOORS AND IGNITION LOCK SETS**



**Doors**

- '70 - '77    ..... LCK23 .....set ..... 19.95



**LCK3**



**LCK4**



**LCK25**

**Doors / Ignition**

- '70 - '73    ..... LCK3 .....set ..... 29.95
- '73 - '75    ..... LCK4 .....set ..... 34.95
- '76 - '77    ..... LCK25 .....set ..... 39.95

**GRILLE LAMP RELATED**



**Housing**

Includes mounting studs, socket, bulb, and wiring pigtail with correct connector. Left and right are the same. Requires 2 per car.

- '71 - '74   '71 - '72 Maverick Grabber; '73 - '74 Maverick before 8/12/74; '71 - '74 Comet; all with grille-mounted lamps.



- ..... D1DZ-13200 .....ea ..... 44.95

**GRILLE LAMP RELATED CONTINUED**



**Bezels**

Exact reproductions of the originals. Black with chrome-plated trim.

- '71 - '74   Maverick before 8/12/74; Comet; all with grille-mounted lamps.



- ..... C9WY-13210 .....pr ..... 134.95



**Lenses**

Clear with Ford oval script. Made in the USA.

- '71 - '72   Maverick with grille-mounted lamps.  
 ..... C9WY-13208-9A .....pr ..... 39.95



**Lens Gaskets**

- '71 - '74   '71 - '72 Maverick Grabber; '73 - '74 Maverick; '71 - '74 Comet; all with grille-mounted lamps.

- ..... C9WY-13211 .....pr ..... 2.95

**PARKING LAMP RELATED**



**Lens Gaskets**

- '70 - '72   ..... D0DZ-13211A .....pr ..... 6.95



**Lamp Socket**

Replacement. Includes pigtail wiring. Will accept a number 1157 bulb.

- '70 - '72   ..... S36N .....ea ..... 8.95

**Lamp Bulbs - Replacement**

Fits many Ford and Mercury applications and is sometimes used in multiple lights. Replaces industry #1157 bulb. Sold in a package of 2 bulbs.

- ..... C8TZ-13466A .....pr ..... 4.95

**MARKER LAMP RELATED**



**Front and Rear Marker Lamp Bezels Set**

LH and RH, front and rear. Chrome outer trim with argent painted interior. Excellent reproductions.

- '70 - '77    ..... D0DZ-15A20140 .....set ..... 125.95

**MARKER LAMP RELATED CONTINUED**

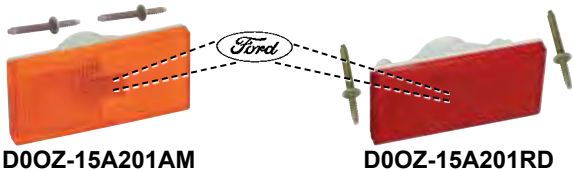

**Marker Lamp Housings and Lenses**

Excellent reproduction officially licensed by Ford. Includes 2 mounting studs. Made in the USA.

- '70 - '77 Front. Amber lens. ..... D0OZ-15A201AM .....ea ..... 22.95
- Rear. Red lens. ..... D0OZ-15A201RD .....ea ..... 22.95



**Marker Lamp Housing Mounting Studs**

- '70 - '77 Maverick; '71 - '77 Comet. ..... D0ZZ-15201S .....pr ..... 2.50



**Marker Lamp Socket**

Replacement. Features 10" wires for splicing. Fits front or rear.

- '70 - '77 Maverick; '71 - '77 Comet. ..... D0DZ-15A434B .....ea ..... 5.95



**Lamp Bulbs - Replacements**

Fits many Ford and Mercury applications and are sometimes used in multiple lights. Replaces industry #194 bulb. Package of 2 bulbs.

- ..... C2AZ-13466C .....pr ..... 4.95



**Rear Marker Lamp Lens Gaskets**

**NOTE:** These are a little thicker than OE, but they will work.

- '70 - '77 ..... D0ZZ-15209 .....pr ..... 2.50

**Rear Marker Lamp-to-Body Seals**

Goes between lamp housing and car body.

- '71 - '77 ..... D1DZ-15A447A .....pr ..... 9.95

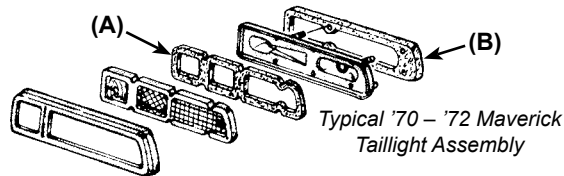

**TAILLIGHT RELATED**



**Taillight Lens Gaskets (A)**

- '70 - '77 Maverick ..... D0DZ-13461B .....pr ..... 4.95
- '71 - '77 Comet. ..... D0GY-13461B .....pr ..... 10.95

**TAILLIGHT RELATED CONTINUED**



**Taillight-to-Body Pads (B)**

- '70 - '77 Maverick ..... D0DZ-13420B .....pr ..... 9.95
- '71 - '77 Comet. ..... D0GY-13A495D .....pr ..... 12.95

**Taillight Socket**

Replacement. Includes pigtail wiring. Will accept a number 1157 bulb.

- '70 - '72 ..... S36N .....ea ..... 8.95



**Taillight Bulbs - Replacement**

Fits many Ford and Mercury applications and is sometimes used in multiple lights. Replaces industry #1157 bulb. Sold in a package of 2 bulbs.

- ..... C8TZ-13466A .....pr ..... 4.95



**REAR LAMP BULB SOCKET AND WIRING**

Replacement. Clip-in type. Accepts a number 1157 bulb.

- '70 - '77 ..... S75 .....ea ..... 9.95



**LICENSE PLATE LAMP RELATED**

**Lamp Cover**

- '70 - '72 Maverick; '71 - '72 Comet. ..... C5OZ-13566B .....ea ..... 6.95

**Lamp Lens**

- '70 - '76 Maverick; '71 - '72 Comet. ..... C4AZ-13564A .....ea ..... 12.95

**Lens Gasket**

- '70 - '76 Maverick; '71 - '72 Comet. ..... C7AZ-13568A .....ea ..... 1.00

**Moulding**

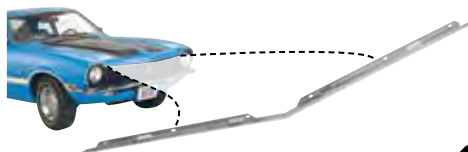

**HOOD MOULDING**

Mounts to the front edge of the hood. This high-quality bright anodized aluminum hood moulding can be painted to match the body color.

**NOTE:** There is a \$10.00 per order boxing fee for this item.

- '70 - '77 ..... D0DZ-16856A .....ea ..... 169.95



**QUARTER WINDOW MOULDINGS**

Chrome-plated reproductions with squared corners for vehicles with belt moulding. Despite the squared corners, they still look great on vehicles without the belt moulding. Includes mounting hardware.

- '70 - '77 2-door. ..... D0DZ-6229796PR .....pr ..... 139.95

**BF** Boxing Fee    **OS** Oversize    **TF** Truck Freight

## Emblems



DODZ-8213B



D0DZ-6242528A



**GRILLE EMBLEMS**  
Excellent reproduction.

**Center Ornament and Bezel**

'70 - '72 Maverick..... D0DZ-8213B.....ea ..... 124.95

**Nameplate Emblem**

Chrome-plated die-cast metal with an adhesive back. Officially licensed.

**NOTE:** Must use your original painted base.

'71 - '74 Maverick..... D0DZ-6242528A.....ea ..... 26.95



**FENDER EMBLEM**

Excellent reproduction. Includes mounting hardware.

'70 - '74 '70 - '72 Maverick all; '73 - '74 Maverick except luxury decor ..... D0DZ-16098A.....ea ..... 29.95

**NON-STOCK FENDER EMBLEMS**

Plastic with industrial-grade plating and double-sided tape for easy installation.



KPP5093



KPP5094



KPP5095

**Rectangles**

Chrome numbers and border, black background. 3 1/8" long x 3/4" tall.

"302" ..... KPP5093.....ea ..... 14.95

"351" ..... KPP5094.....ea ..... 14.95

"390" ..... KPP5095.....ea ..... 14.95



**Open Numbers**

Chrome numbers with black border and red inside the decimal. 4 1/8" long x 1 1/8" tall.

"5.0" 302 ..... 2155151.....ea ..... 9.95



**TRUNK EMBLEM**

Excellent reproduction. Chrome-plated die-cast metal with an adhesive back. Will fit trunk lid or add-on spoiler on all '70 - '77 Mavericks. Officially licensed by Ford.

'70 - '74 Maverick..... D0DZ-6242528A.....ea ..... 26.95



378362S



AV11293



AV8405

**TUBE NUTS (BARREL CLIPS)**

Used to attach to your vehicle emblems that have pins on the back. They are not necessary for self-adhesive emblems.

Small Fits 1/16" stud, 1/8" panel hole.  
..... 378362S .....ea ..... 50

Medium Fits 1/8" stud, 3/16" panel hole.  
..... AV11293 .....ea ..... 50

Large Fits 3/16" stud, 1/4" panel hole.  
..... AV8405 .....ea ..... 1.00



**PLASTIC EMBLEM ADHESIVE - CLEAR**

Excellent for plastic repair and emblem application. It may be used for interior or exterior bonding on metal emblems, rigid plastic parts, taillight lenses, and vinyl trim strips. Strong, quick-drying and requires only a one-surface application.

5 oz. tube ..... 08061.....ea ..... 16.95

## Stripe Kits and Exterior Decals

**NOTE:** If stripe kits are not going to be installed immediately, do not expose them to extreme temperatures.

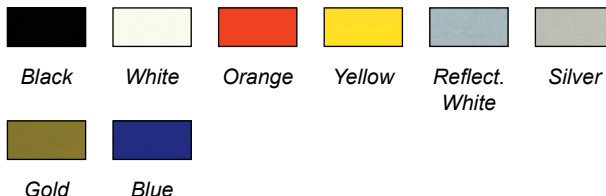

**MAVERICK GRABBER STRIPE KITS AND DECALS**

Officially licensed by Ford.

**NOTE:** These kits are custom-made and are not returnable unless defective. Please allow 3 to 4 weeks for delivery.



'70 **Side Stripes Only**

Does not include "Grabber" name or trunk stripe. Non-reflective.

Black ..... M100BK.....kit ..... 149.95

White ..... M100WH.....kit ..... 149.95



**M200BKOR**  
(LH Fender)

'71 **Side Stripes Only**

Does not include trunk stripe. "Grabber" name on front fenders is the accent color, the same as the pinstripes. Non-reflective black.

..... M200BK.....kit ..... 149.95

Non-reflective white.  
..... M200WH.....kit ..... 149.95

Reflective black / orange.  
..... M200BKOR.....kit ..... 269.95

Reflective black / yellow.  
..... M200BKYE .....kit ..... 269.95

Reflective white / white.  
..... M200WHWH .....kit ..... 269.95



'71 - '72 **"Grabber" Fender Decals**

Orange / black..... DF914 .....ea ..... 13.50

Yellow / black ..... DF915 .....ea ..... 13.50

Silver / black..... DF916 .....ea ..... 13.50

**NOTE:** While we take great care to present the colors as true as possible to the actual color, their accuracy is not guaranteed, due to the limitations of the printing process.

**MAVERICK GRABBER STRIPE KITS AND DECALS CONTINUED**

'72 **Side Stripes and Trunk Stripe**  
 "Grabber" name on front fenders is the accent color, the same as the pinstripes.  
 Non-reflective black.. M300BK .....kit..... 149.95  
 Non-reflective white.. M300WH.....kit..... 149.95



'72 **Twin Scoop Hood Decals**  
 Has 2 center stripes with a pinstripe around the outside.  
 Black. Matches stripe kit #M300BK.  
 ..... M310HBK .....ea ..... 139.95  
 Gold / white ..... M310HGDWH .....ea ..... 139.95

*NOTE: On '73 - '75 Grabbers, area below lower stripe was painted to match the stripe.*

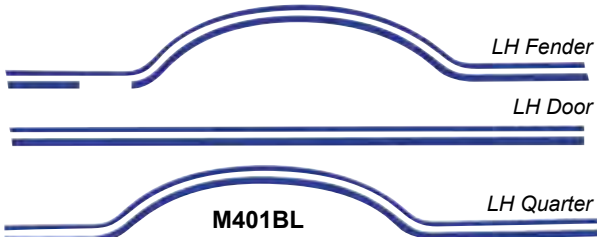
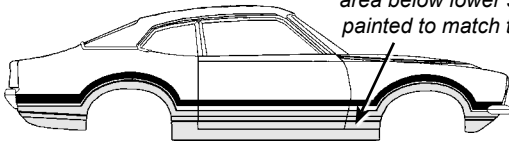

'73 **Side Stripes and Trunk Stripe**  
 For "Grabber" name, you must use Grabber paint stencil #M420ST (see below).  
 Non-reflective black.  
 ..... M401BK .....kit..... 169.95  
 Non-reflective blue.  
 ..... M401BL .....kit..... 169.95  
 Non-reflective off-white.  
 ..... M401AWH.....kit..... 169.95



'73 **"Grabber" Paint Stencil**  
 Installs on lower fender and allows paint color to show through ..... M420ST .....kit..... 29.95

'74 - '75 **Hood Decals**  
 Black ..... M400HBK .....ea ..... 99.95  
 Blue ..... M400HBL .....ea ..... 99.95  
 Off-white ..... M400HAWH .....ea ..... 99.95

**MAVERICK GRABBER STRIPE KITS AND DECALS CONTINUED**



'74 - '75 **Side Stripes**  
 Has "Grabber" name in the stripe. No trunk stripe available. For Grabber tail panel stencil (not all vehicles had this option), see part #M520ST below.  
 Non-reflective black.

..... M500BK .....kit..... 189.95  
 Non-reflective blue.  
 ..... M500BL .....kit..... 189.95  
 Non-reflective off-white.  
 ..... M500AWH.....kit..... 189.95

'74 - '75 **Tail Panel Paint Stencil**  
 Allows paint color to show through the "Grabber" name in the painted area between the taillights. Requires 1.  
**NOTE:** Not all vehicles had this option.  
 ..... M520ST .....ea ..... 24.95

**COMET GT STRIPE KITS**

**NOTE:** These kits are not returnable for a refund. We will only replace defective parts.



'71 - '72  
 Black.  
 🐎 ..... D14Y-6220000B .....kit..... 99.95  
 Silver.  
 🐎 ..... D14Y-6220000S .....kit..... 99.95  
 White.  
 🐎 ..... D14Y-6220000W .....kit..... 99.95



'73 - '74  
 Black.  
 🐎 ..... D34Y-6220000B .....kit..... 149.95  
 Silver.  
 🐎 ..... D34Y-6220000S .....kit..... 149.95  
 White.  
 🐎 ..... D34Y-6220000W .....kit..... 149.95



**MISCELLANEOUS EXTERIOR DECALS**

**Stallion Fender Decals**

'76 - '77 **Maverick Stallion.**  
 LH ..... DF816 .....ea ..... 17.50  
 RH ..... DF815 .....ea ..... 17.50



**MISCELLANEOUS EXTERIOR DECALS  
CONTINUED**

**"U.S.A." Quarter Panel Shield**

'72 Maverick Sprint. Requires 2 per vehicle.  
..... DF391 .....ea ..... 10.50



**BUMPERS – NEW**

Quality triple-chrome plated steel reproductions. Chromium-nickel electroplated for better corrosion resistance, durability, and shine.

**NOTE:** Does not have holes for bumper guards.

**NOTE:** These are oversize items; additional shipping charges apply.

**Front**

Can be adapted to fit '73 – '77 using earlier-model Maverick bumper brackets (part #D0DZ-1775467SET, below) lower valance (part #D0DZ-17626A, next column), and stone deflector (part #D0DZ-17779A, next column).

'70 – '72 Without guards ..... D0DZ-17757A .....ea ..... 495.00

**Rear**

Can be adapted to fit '74 – '77 using earlier-model Maverick bumper brackets (part #D0DZ-17A750A, below), lower valance (part #D0DZ-6240544A, page 36), inner trunk bracket braces (part #D1ZZ-17B862A, below) (some welding required), and quarter panel extensions (not available new).

'70 – '73 Without guards.  
..... D0DZ-17906A .....ea ..... 469.95



D0DZ-17A750A

**BUMPER BRACKETS**

LH and RH. Heavy gauge steel with durable corrosion-resistant black finish.

'70 – '72 Front.  
4-piece set (inner and outer).  
..... D0DZ-1775467SET .....set ..... 194.95  
Rear.  
..... D0DZ-17A750A .....pr ..... 99.95



**REAR BUMPER BRACKET BRACES**

LH and RH.

'70 – '73 Maverick; '72 – '73 Comet.  
..... D1ZZ-17B862A .....pr ..... 34.95



FO193

**BUMPER BOLT KITS**

Each kit does both front and rear bumpers.

'70 – '72 20 pieces ..... FO193 .....kit ..... 22.95  
'74 – '77 40 pieces ..... FO196 .....kit ..... 32.95



SPMV1

**FRONT SPOILERS**

ABS plastic, aftermarket spoilers. Requires minor modification to bolt onto your Maverick or Comet.

**NOTE:** These are oversized items. Additional shipping charges apply.

'70 – '72 Maverick; '71 – '72 Comet.  
53" L x 4 3/4" W ..... SPMV1 .....ea ..... 49.95  
53" L x 3 3/4" W ..... SPMV2 .....ea ..... 49.95

**Sheet Metal**

**NOTE:** Due to parcel size restrictions, some items must be shipped via commercial truck lines, with the shipping charges prepaid to Auto Krafters by the customer. Call before ordering for shipping charges. Minimum truck shipment charges start at \$60.00. Please provide a business address for delivery when ordering.

**NOTE:** A \$10.00 boxing fee will be added per order for all sheet metal.

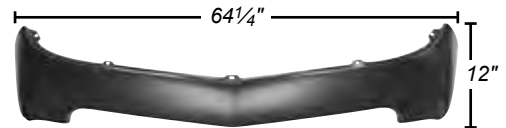

**FRONT LOWER VALANCE PANEL**

18 gauge steel.

**NOTE:** This is a \$10.00 per order boxing fee for this item.

**NOTE:** This is an oversize item; additional shipping charges apply.

'70 – '72 ..... D0DZ-17626A .....ea ..... 239.95

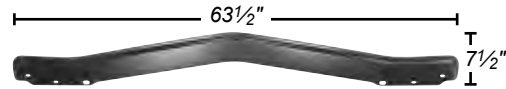

**FRONT BUMPER STONE DEFLECTOR**

18 gauge steel.

**NOTE:** This is an oversize item; additional shipping charges apply.

'70 – '72 Maverick ..... D0DZ-17779A .....ea ..... 149.90

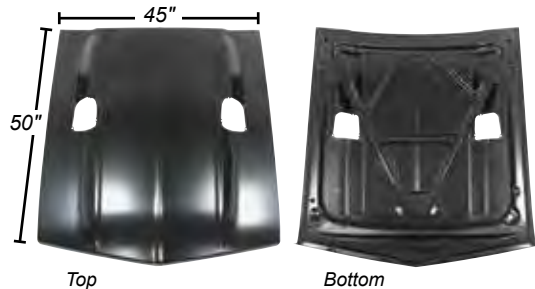

**HOOD AND RELATED**

**Hood – Steel**

Grabber-style hood with scoop holes. Scoops sold separately (see part #D1DZ-167201A on next page). 18 gauge steel.

**NOTE:** There is a \$10.00 per order boxing fee for this item.

**NOTE:** This item must ship via truck freight. Please call for a shipping quote.

'71 – '72 Maverick.  
**NOTE:** Will fit '70 – '77 as aftermarket, but is correct for '71 – '72 ..... D1DZ-16612A .....ea ..... 499.95

**BF** Boxing Fee    **OS** Oversize    **TF** Truck Freight

**HOOD AND RELATED CONTINUED**



**Hood Scoops**

Excellent reproductions. For use on Grabber-style hood #D1DZ-16612A (see previous page).

'71 - '72   Maverick.  
**NOTE:** Will fit '70 - '77 as aftermarket, but is correct for '71 - '72..... D1DZ-167201A.....pr ..... 139.95



**D0DZ-16006B**

**FRONT FENDERS** **BF OS**

Correct reproductions for '70 - '72 Maverick / '71 - '72 Comet, with a notch for the stone deflector. 18 gauge steel.

**NOTE:** Will also fit '73 - '77 Maverick / Comet, which did not have the notch.

**NOTE:** There is a \$10.00 per order boxing fee for these items.

**NOTE:** These are oversized items; additional shipping charges apply. Please call for a shipping quote.

'71 - '72   LH.  
 ..... D0DZ-16006B.....ea ..... 379.00  
           RH.  
 ..... D0DZ-16005B.....ea ..... 379.00



**C6OZ-3383A C6OZ-3382A**

**OUTER SHOCK TOWER COVERS** **MP NEW**

Stamped from high-quality OE-gauge steel and features the correct shape, size, bends, ribs, holes, and tabs as the original.

'70 - '72   LH.  
 ..... C6OZ-3383A.....ea ..... 79.95  
           RH.  
 ..... C6OZ-3382A.....ea ..... 79.95

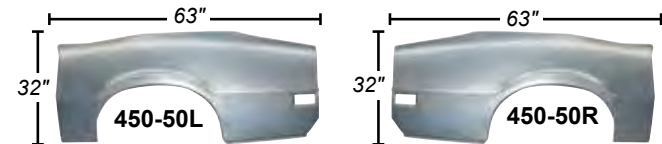

**FULL QUARTER PANELS** **BF TF**

19 gauge steel.

**NOTE:** These items are shipped via truck freight. Please call for a shipping quote.

**NOTE:** There is a \$10.00 per order boxing fee for these items.

'70 - '77   2-door. Must be cut down for 4-door.  
           LH.  
 ..... 450-50L.....ea ..... 259.95  
           RH.  
 ..... 450-50R.....ea ..... 259.95

**QUARTER PANEL DRAIN VALVES**

Use with 1 1/2" square hole.  
 '70 - '73 Maverick; '71 - '72 Comet.  
 ..... C7ZZ-6511202.....pr ..... 9.95

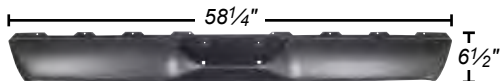

**REAR VALANCE PANEL** **BF OS**

Reproduction. 19 gauge steel.

**NOTE:** There is a \$10.00 per order boxing fee for these items.

**NOTE:** These are oversized items; additional shipping charges apply.

'70 - '72   '70 - '72 Maverick; '71 - '72 Comet.  
 ..... D0DZ-6240544A.....ea ..... 269.95



**SPARE WHEEL MOUNTING BRACKET** **MP NEW**

Stamped from high-quality heavy-gauge steel and features the correct shape, size, bends, ribs, holes, and tabs as the original.

'70 - '77   ..... C7AZ-6247076A.....ea ..... 14.99

**Hood Scoops**

**301-SCOOP-1**

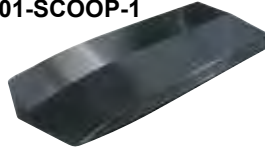

**301-SCOOP-2**

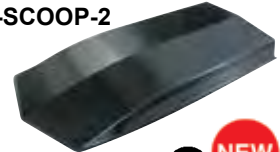

**STEEL HOOD SCOOPS - UNIVERSAL** **MP OS NEW**

Cowl induction-style steel hood scoops. Can be modified to fit any application. Installation will require cutting the scoop to the desired length and forming the scoop to the curvature of your vehicle's hood. We recommend welding the scoop in place. Once welded, the scoop must be body-worked prior to painting.

**NOTE:** These are oversize items; additional shipping charges apply.

2" rise. Measures 53 3/4" x 24" x 2 1/4".  
 ..... 301-SCOOP-1.....ea ..... 179.99  
 4" rise. Measures 55 3/8" x 24 7/8" x 5".  
 ..... 301-SCOOP-2.....ea ..... 179.99

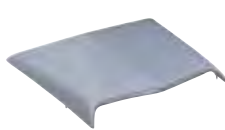

**GT HOOD SCOOP** **BF OS**

Scoop only. 25" x 26" x 3" at the deepest points. Bolt on.

**NOTE:** Does not bolt to factory holes; must drill new holes.

**NOTE:** There is a \$10.00 per order boxing fee for these items.

**NOTE:** These are oversized items; additional shipping charges apply.

'71 - '77   Comet.  
 ..... C9WY-16C630B.....ea ..... 199.95

**Exterior Hardware**



01IG  
 Stamp on Top

**AK341B**



HTS  
 Stamp on Top

**AK433C**



Stamp on Top

**57140-S8**



Stamp on Top

**AV10823**

**FENDER BOLTS**

'70 - '77   Requires 12.  
           5/16" - 18 x 1". With star washer. Has "01IG" stamped on top. Black ..... AK341B.....ea ..... 1.00  
 '70 - '77   5/16" - 18 x 1 5/16". Requires 12.  
           With star washer. Has "HTS" logo on top. Cadmium.  
           ..... AK433C.....ea ..... 1.50  
           With disc washer. Has flag on top. Zinc-plated.  
           ..... 57140-S8.....ea ..... 1.50  
 '70 - '77   1/4" - 20 x 7/8". With disc washer (washer O.D.: 3/4"). 7/16" hex). Has "LF" stamped on top. Parkerized.  
           For use with U-nuts #AV10050 and #AV10051 (next page).  
           ..... AV10823.....ea ..... .50

**BF** Boxing Fee   **OS** Oversize   **TF** Truck Freight



**FENDER MOUNT U-NUTS**

'70 - '77	1/4" - 20. 1 7/32" center of hole to edge. Use with body bolt #AV10823 (previous page).....	AV10050 .....ea	50
	25/32" center of hole to edge. Use with body bolt #AV10823 (previous page).....	AV10051 .....ea	60
'70 - '77	5/16" - 18 with 27/32" hole. Long reach. Requires approximately 10 per vehicle. .....	AV8814 .....ea	50
	Set of 12.....	AK119 .....set	5.00



Stamp on Top

AV9756



**BODY BOLTS**

'70	5/16" - 18 x 1. Has "LF" stamped on top. Requires 12. .....	AV9756 .....ea	40
	5/16" - 18 x 1 5/16". With flat washer. Has flag stamped on top. Zinc plated.....	57140-S8 .....ea	1.50



FO1785A

**EXTERIOR SCREW KITS**

A typical kits includes screws for headlamp moulding, exterior (side-view) mirror, license plate lamp mounting, and license plate lamp lens.

'74 - '77	Includes screws for wheelhouse moulding. 39 pieces.....	FO1785A .....kit	12.95
'75 - '77	11 pieces.....	FO1785 .....kit	4.95

**Wheels and Related**

**NOTE:** Once a wheel has been mounted, it is non-returnable; check for fit on your vehicle before mounting. Please read all installation / application instructions.

**CRAGAR® WHEELS AND RELATED**



Cragar® S/S Wheel

**Cragar® Chrome S/S Super Sport Wheels**

Composite chrome steel rim with a 5-spoke, chrome aluminum center. Includes center cap. For lug nuts, see part #277234 below.

	14 x 6 -3 mm offset. 3 3/8" back spacing. 5 x 4.5", 4.75", 5" bolt circle. .....	61614 .....ea	219.95
14 x 7	+3 mm offset. 4 1/8" back spacing. 5 x 4.5", 4.75", 5" bolt circle.....	61714 .....ea	179.95
15 x 7	+3 mm offset. 4 1/8" back spacing. 5 x 4.5", 4.75", 5" bolt circle. .....	61715 .....ea	219.95
15 x 8	-6 mm offset. 4 1/8" back spacing. 5 x 4.5" bolt circle. .....	61815 .....ea	189.95



**Cragar® Short Shank Lug Nut Set**

Fits Cragar® wheels with 5 x 4.5", 4.75", 5" bolt circle. Mag-style lug nuts with .800" shank and 1/2 - 20 RH threads. Includes 4 offset hole washers.

.....	277234 .....set	15.95
-------	-----------------	-------



Typical Torq-Thrust "D"



Typical Torq-Thrust II

**AMERICAN RACING EQUIPMENT TORQ-THRUST WHEELS**

1-piece alloy with machined lip. Includes center caps. Lug nuts sold separately (part #64000, below).

**NOTE:** These will not work on vehicles with oversized brake calipers.

**Torq-Thrust "D" Wheels**

Painted center with satin-finish outer ring.

14 x 6	3.42" backspacing. Black center.....	AR1054665BK .....ea	109.95
14 x 6	3.75" backspacing. Gray center.....	AR1054665 .....ea	109.95
15 x 6	3.66" backspacing. Black center. .....	AR1055665BK .....ea	119.95
15 x 6	3.75" backspacing. Gray center. .....	AR1055665 .....ea	119.95
15 x 7	3.76" backspacing. Black center.....	AR1055765BK .....ea	129.95
15 x 7	3.75" backspacing. Gray center.....	AR1055765 .....ea	129.95

**Torq-Thrust II Wheel**

Polished finish.

14 x 6	0.75" offset, 3.37" back spacing. 5 x 4 1/2" bolt circle. .....	VN5154665 .....ea	149.95
--------	--	-------------------	--------



**McGARD® TOUGH NUTS**

Regular cone seat. Set of 4.

.....	64000 .....set	8.95
-------	----------------	------

**LEGENDARY SERIES ALLOY WHEELS AND RELATED**



Typical Legendary Styled Alloy Wheel



Lug Nuts and Center Cap Sold Separately

**Legendary Series Styled Alloy Wheels**

1-piece cast-aluminum alloy wheels with machined finish rims and charcoal inlays. Resembles original-style '65 Mustang styled steel wheels.

**NOTE:** Wheel fitment and clearance in all aspects are customer's responsibility. May not work on vehicles with oversized calipers.

**NOTE:** There is a \$15.00 per wheel charge for shipping within the lower 48 U.S. states.

	5 x 4 1/2" bolt pattern.		
15 x 7	4 1/4" backspacing. Charcoal inlay. .....	STYLED15X7ALCH .....ea	169.95
16 x 8	4 1/2" backspacing. Charcoal inlay. .....	STYLED16X8ALCH .....ea	184.95



Lug Nuts and Center Cap Sold Separately

**Legendary Series GT5 Alloy Wheels**

1-piece cast-aluminum alloy wheels machined details and a clear coat finish. Resembles original-style '65 Shelby GT350 steel wheel.

**NOTE:** Wheel fitment and clearance in all aspects are customer's responsibility. May not work on vehicles with oversized calipers.

**NOTE:** There is a \$15.00 per wheel charge for shipping within the lower 48 U.S. states.

	5 x 4 1/2" bolt pattern.		
15 x 7	4 1/4" backspacing. .....	GT5-15X7AL .....ea	199.95

**LEGENDARY SERIES ALLOY WHEELS AND RELATED CONTINUED**

**Legendary Series Magnum 400 and 500 Wheels**

Reproduction Magnum-style CNC-machined alloy wheels, featuring a bold spoke design that is ideal for classic cars, providing ample clearance and more tire options.

For center caps, see the next column.

For lug nuts / wheel installation kits, see the next column.

**NOTE:** Wheel fitment and clearance in all aspects are customer's responsibility. May not work on vehicles with oversized calipers.

**NOTE:** There is a \$15.00 per wheel charge for shipping within the lower 48 U.S. states.

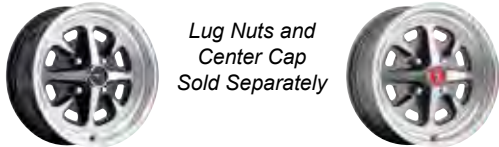

Lug Nuts and Center Cap Sold Separately

**MAG40015X6BLK**

**MAG40015X6CHAR**

**Magnum 400 Wheels**

4 × 4½" bolt pattern. 3.75" backspacing.

- 14 × 6 Gloss black inlay.  
 ..... MAG40014X6BLK .....ea ..... 159.95
- 15 × 6 Gloss black inlay.  
 ..... MAG40015X6BLK .....ea ..... 165.95
- Charcoal inlay.  
 ..... MAG40015X6CHAR .....ea ..... 165.95

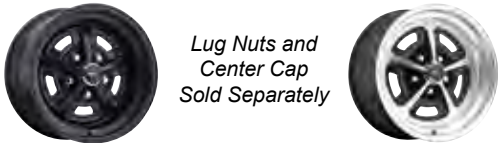

Lug Nuts and Center Cap Sold Separately

**MAG15X7ALBLACK**

**MAG15X7ALST**

**Magnum 500 Wheels**

5 × 4½" bolt circle.

- 15 × 7 4¼" backspacing.  
 Stealth black finish on the entire wheel.  
 ..... MAG15X7ALBLACK .....ea ..... 169.95
- Charcoal inlay with machined finish rim.  
 ..... MAG15X7ALCH .....ea ..... 169.95
- Gloss black inlay with machined finish rim.  
 ..... MAG15X7ALGL .....ea ..... 169.95
- Satin black inlay with machined finish rim.  
 ..... MAG15X7ALST .....ea ..... 169.95
- 15 × 8 4¾" backspacing.  
 Gloss black inlay with machined finish rim.  
 ..... MAG15X8ALGL .....ea ..... 184.95
- 16 × 8 4½" backspacing.  
 Satin black inlay with machined finish rim.  
 ..... MAG16X8ALST .....ea ..... 184.95



**LN002**

**LN003**

**Legendary Series Wheel Lug Nuts**

For Legendary alloy wheels. Chrome shanked lug nuts, ½" – 20, hex.

- 13/16".  
 ..... LN002 .....ea ..... 1.95
- ¾".  
 ..... LN003 .....ea ..... 1.95

**LEGENDARY SERIES ALLOY WHEELS AND RELATED CONTINUED**



**LN002-20**

**Legendary Series Wheel Installation Kits**

For Legendary alloy wheels. Kits include chrome lug nuts (½" – 20, 13/16" hex) and rubber valve stems with chrome sleeve and cap.

- 4-lug Includes 16 lug nuts and 4 rubber valve stems.  
 ..... LN002-16 .....kit ..... 35.95
- 5-lug Includes 20 lug nuts and 4 rubber valve stems.  
 ..... LN002-20 .....kit ..... 39.95



**HC007**

**HC014**

**HC016**

**Legendary Series Wheel Center Caps**

For use on Legendary alloy wheels. Precision die-cast for a perfect fit. Show-quality finish and correct accent colors. Features an easy-to-install mounting system that works exclusively on the Legendary wheels to eliminate the risk of caps being lost or stolen.

- Black Ford crest ..... HC007 .....ea ..... 34.95
- Bullseye.  
 ..... HC014 .....ea ..... 24.95
- Shelby CS ..... HC016 .....ea ..... 35.95

**HC033-MAG500**

**HC033-BULLSEYE**



**Legendary Series Wheel 3-Bar Spinners**

For use on Legendary alloy wheels. Precision die-cast for a perfect fit. Show-quality finish and correct accent colors. Features an easy-to-install mounting system that works exclusively on the Legendary wheels to eliminate the risk of caps being lost or stolen.

- Magnum 500.  
 ..... HC033-MAG500 .....ea ..... 35.95
- Bullseye.  
 ..... HC033-BULLSEYE .....ea ..... 35.95

**MAGNUM 500 WHEELS AND RELATED**



Magnum 500 Wheel

**Magnum 500 Wheels**

5-lug wheels. 1-year warranty on finish, provided the wheels are not abused. Center caps and 3-bar wheel spinners sold separately.

**NOTE:** May not work on vehicles with oversized brake calipers.

- 14 × 6 Offset: +6.00 mm, backspacing: 3¾".  
 ..... MAG14X6 .....ea ..... 174.95
- 14 × 7 Offset: +6.00 mm, backspacing: 4¼".  
 ..... MAG14X7 .....ea ..... 174.95
- 15 × 6 +12.00mm (0.47244095") offset; 4" backspacing.  
 ..... MAG15X6 .....ea ..... 189.95
- 15 × 7 Offset: +6.00 mm, backspacing: 4¼".  
 ..... MAG15X7 .....ea ..... 189.95
- 15 × 8 Offset: +0 mm, backspacing: 4½".  
 ..... MAG15X8 .....ea ..... 189.95





C9OZ-1130BK

D6OZ-1130B

MW-0269-02

**MAGNUM 500 WHEELS AND RELATED CONTINUED**

**Center Cap**

Chrome with Ford crest in center.

- '70 - '77 **Early Style**
- Black background... C9OZ-1130BK .....ea ..... 39.95
- Red background.... C9OZ-1130RD .....ea ..... 39.95
- Late Style**
- Red background.... D6OZ-1130B.....ea ..... 39.95

**3 Bar Spinners**

Die-cast exact reproductions of Motor Wheel spinners. Set of 4.

- '70 - '77 ..... MW-0269-02 .....set..... 139.95

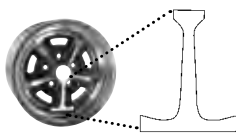

**MAGNUM 500 WHEEL PAINT SEAL KIT**

Template to paint Magnum 500 wheels. This kit consists of two sheets of die-cut, peel-and-stick masks that shield the chrome spokes when repainting Mag wheels.

- ..... FAM748 .....kit..... 19.95



**AMERICAN RACING EQUIPMENT ANSEN SPRINT WHEEL SET**

Set of 4. Includes center caps. Lug nuts sold separately (see part #S2MS-1012A in the next column).

- '70 - '72 Maverick 6-cylinder; '71 - '72 Comet 6-cylinder. 15 x 7. Offset: 0, Backspacing: 4". Bolt circle: 4 x 4 1/2".  
..... A695748SET .....set..... 695.00



**1009 WHEEL VINTIQUES SMOOTHIE WHEELS AND HUBCAP**

**Series 10 Chrome Smoothie Wheels**

Add a great custom look at an affordable price. 2-piece steel construction with chrome-finish outer surface. Can be used with stock lug nuts.

For chrome baby moon hubcap, see part #1009 below.

- '70 - '72 Maverick 170 / 200 with 14" wheels; '71 - '72 Comet 170 / 200 with 14", 4-lug wheels. 14 x 6. Backspacing: 4". Bolt circle: 4 x 4 1/4", 4 1/2".  
..... 10460404 .....ea ..... 129.95
- '71 - '77 302 with 14", 5-lug wheels. 14 x 6. Backspacing: 4". Bolt circle: 5 x 4 1/2", 4 3/4". Offset: +12.00 mm. Center bore diameter: 3 1/4".  
..... 10461204 .....ea ..... 129.95

**Chrome Baby Moon Hubcap**

Snaps into the center of your chrome Smoothie wheel, giving you a great custom look. For chrome Smoothie wheels, see above.

- '70 - '72 Maverick 170 / 200 with 14" wheels; '71 - '72 Comet 170 / 200 with 14" wheels.  
..... 1009 .....ea ..... 34.95



**BABY MOON HUB CAPS**

Made of strong steel to resist denting and chrome plated for lasting beauty. Fits most Ford 14" or 15" stock wheels. 10 1/8" inside diameter. Set of 4.

- ..4580.....set..... 79.95



**LUG NUTS**

'70 - '77 Standard.

- ..... C0AZ-1012A .....ea ..... .65
- ..... S2MS-1012A .....ea ..... 1.50



**MCGUARD® WHEEL LOCK KIT**

For 4-lug wheels with 1/2" lug nuts. Includes 4 locking lug nuts and 1 socket.

- ..... 24130 .....kit..... 21.95

A = 1/2" - 20      B = 1.615" / 1.635"      B = 1.720" / 1.750"  
C = .618" / .628"      D = .440" / .460"      D = .445" / .460"

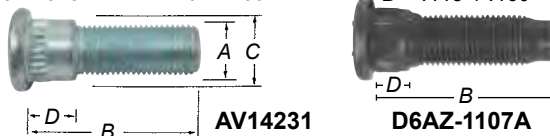

**WHEEL STUD BOLTS**

1/2" - 20.

- '70 - '77 Grade 8. Press-in.  
..... AV14231 .....ea ..... 1.95
- '76 - '77 Rear ..... D6AZ-1107A .....ea ..... 1.00



**TOPLINE® SLIDE RULE PCD GAUGE**

This plastic slide-rule gauge measures the distance between lug nuts. For wheels with 4 to 8 holes. .... C402 .....ea ..... 24.95



**GORILLA® POWER LUG WRENCH**

Removes tight lug nuts easily. Constructed from hardened steel, the telescoping handle extends to 21" for maximum leverage. Includes a 3" extension and 2 thin-wall sockets - 19 mm (3/4"), 21 mm (13/16") - that work on both deep-dish wheels and all recessed lug holes. .... 1334 .....ea ..... 31.95

**Glass**



**WINDSHIELD GLASS**

Tinted and shaded. Import.

**NOTE:** Tint simulate the original Ford Sun-X® tinting option.

**NOTE:** There is a \$15.00 per order boxing fee for this item.

**NOTE:** Shipped via truck freight. Additional shipping charges apply.

- '70 - '77 ..... W797 .....ea ..... 275.00



**WINDSHIELD REMOVAL TOOL**

Features a steel cable pull handle. Cuts the butyl adhesive caulking around the glass with specially-designed tempered steel blade.

- ..... WSR92065 .....ea ..... 19.95



**WINDSHIELD REMOVAL WIRE KIT**

Cuts and removes front and rear auto glass. Contains 213' of 1/4 lb. wire, wooden handles, and instruction sheet.

- ..... 0564 .....ea ..... 14.95

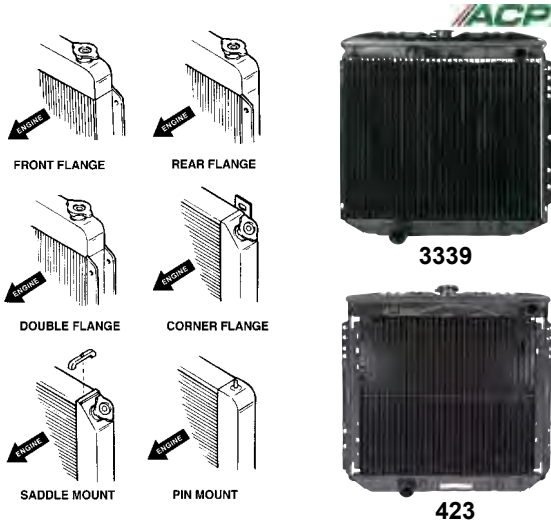

**BRASS / COPPER RADIATORS – OE BLACK FINISH**



**NOTE:** There is a \$10.00 per order boxing fee for all radiators.

**NOTE:** Due to size, additional shipping charges apply.

'70 – '73	'70 – '73 302 without A/C; '71 – '73 250 with or without A/C. 3 row. Core size: 16½" x 20¼" x 2".	..... 3339.....ea ..... 289.95
'74 – '77	Maverick 200 / 250 with or without A/C; 302 without A/C. 2 row. Core size: 16¾" x 20¼" x 1¼".	..... 423.....ea ..... 289.95

**ALUMINUM RADIATORS**



New, all-aluminum, high-performance radiators featuring modern, high-density cores, allowing for better cooling.

**NOTE:** These are oversized items; additional shipping charges apply.



3339ALAT

339ALMK

**OE-Style Appearance**

2 rows of 1¼" tubes for more water flow and better cooling. Features polished OE-style tanks and corrugated fins (16 per inch) that give more surface area and more thermal transfer. 100% TIG welded.

'71 – '73	Maverick 250 / 302; '71 – '73 Comet 250 / 302. 2 core. Core size: 16.5" x 19.6". Inlet connection: 1½" top right. Outlet connection: 1¾" bottom left.
-----------	--

**Radiators Only**

A/T.	..... 3339ALAT.....ea ..... 320.90
M/T.	..... 3339ALMT.....ea ..... 330.90

**Radiators with Fans**

Includes 16" electric fan kit.

<b>NEW</b> A/T.	..... 339ALAK.....ea ..... 499.90
<b>NEW</b> M/T.	..... 339ALMK.....ea ..... 490.90

**BF** Boxing Fee

**OS** Oversize

**TF** Truck Freight

**ALUMINUM RADIATORS CONTINUED**



329-AMX

339-AMX

**MaxCore – Original-Style Appearance**



Features the classic look that captures the original appearance while improving performance, is a direct fit for the applications listed, and has an A/T cooler. Features 49 tubes per row and 16 fins per inch for expanded flow and improved cooling, and is 100% TIG welded with a billet filler neck.

'70 – '73	'70 Maverick 170 or 200 with or without A/C; '71 – '73 Maverick 170 or 200 without A/C. 2 core. 1¼" tubes. Core size: 20" W x 16½" H x 2⅝" D, inlet connection: 1¼" top right, outlet connection: 1¼" bottom left. Weight: 13.5 lbs.	..... 329-AMX.....ea ..... 319.95
'71 – '73	Maverick 250 with or without A/C; Maverick 302 without A/C. 2 core. 1¼" tubes. Core size: 20" W x 16½" H x 2½" D, inlet connection: 1¼" top right, outlet connection: 1¼" bottom left. Weight: 12.5 lbs.	..... 3329-AMX.....ea ..... 299.95
	3 core. ¾" tubes. Core size: 20" W x 16½" H x 2½" D, inlet connection: 1½" top right, outlet connection: 1½" bottom left. Weight: 12.5 lbs.	..... 339-AMX.....ea ..... 319.95
	3 core. ¾" tubes. Core size: 20" W x 16½" H x 2½" D, inlet connection: 1½" top right, outlet connection: 1½" bottom left. Weight: 12.5 lbs.	..... 3339-AMX.....ea ..... 299.95



**Replacement Style**

Features high-quality T-6061 aluminum construction and direct bolt-on mounting. Includes radiator cap.

**NOTE:** Some stock fan shrouds are not a direct fit. Installer will need to make brackets for installation of shroud.

'71 – '73	Maverick 250 with or without A/C; Maverick 302 without A/C. Core size: 16" x 19⅝" x 2". Inlet connection: 1½" top right. Outlet connection: 1½" bottom left (must use a 1¾" adapter—included—on lower tube).
	2 core ..... 339AL.....ea ..... 199.95
	3 core ..... 339AL3RW.....ea ..... 199.95

**RADIATOR CAPS**

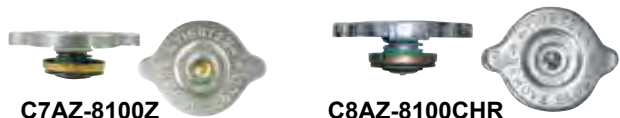

C7AZ-8100Z

C8AZ-8100CHR

**Reproductions – Show Quality**

Autolite. 13 lb.

'70 – '72	Zinc. ..... C7AZ-8100Z.....ea ..... 22.95
	Chrome. ..... C8AZ-8100CHR.....ea ..... 24.95

**Not sure of a term used here?  
Check out the Glossary in the back of this catalog.**

**RADIATOR CAPS CONTINUED**



**RS62**  
**Replacements**  
**Zinc – Motorcraft®**  
 '70 – '77 13 lb.  
 ⚙️ ..... RS62 ..... ea ..... 13.95

**Chrome**  
 14 – 18 lb. for closed system radiator. Hexagonal.  
 ⚙️ ..... 4338 ..... ea ..... 14.95



**Billet**  
**43385** ..... ea ..... 19.95  
 14 – 18 lb. Chrome. Hexagonal. Includes O-ring for standard sized fill neck.  
 ⚙️ ..... 43385 ..... ea ..... 19.95  
 14 lb. Round.  
 ⚙️ ..... B8100 ..... ea ..... 39.95



**THERMOCAP RADIATOR CAP**  
 Improves cooling efficiency, indicates coolant temperature, and helps prevent coolant-related injuries. Using the temperature gauge, you can easily determine whether it is safe to

remove the cap. Fits most domestic vehicles.  
 13 lbs. ⚙️ ..... 2470S ..... ea ..... 39.95



**RADIATOR DRAIN COCK**  
 Brass. Metal-to-metal seats provide leak-proof performance. Takes to 150 PSI pressure. Made in the USA.  
 '70 – '77  
 ⚙️ ..... DV31 ..... ea ..... 3.95



**RADIATOR SUPPORT-TO-HOOD BUMPERS**  
 Rounded.  
 '70 – '77 ..... C5ZZ-16763B ..... pr ..... 6.95



**BRASS FREEZE PLUG KIT**  
 15 pieces, including 6 brass plugs. The expansion plugs help protect the engine against freeze damage and cracks due to inadequate anti-freeze, and the brass plugs eliminate the problem of rusted-out plugs. Good for daily use, ideal for long-term vehicle storage.

'71 – '77 302.  
 ⚙️ ..... 6483 ..... kit ..... 19.95



**RADIATOR HOSES – MOLDED**  
 Features a knitted, reinforced inner tube for maximum strength and burst resistance. Must be trimmed to fit.

**Upper**  
 '70 – '73 250.  
 ⚙️ ..... D2PZ-8260G ..... ea ..... 14.95  
 '70 – '74 170 / 200.  
 ⚙️ ..... D2PZ-8260B ..... ea ..... 12.95  
 '71 – '77 302.  
 ⚙️ ..... D2PZ-8260H ..... ea ..... 14.95

**RADIATOR HOSES CONTINUED**



**Lower**  
 '70 – '74 170 / 200.  
 ⚙️ ..... D2PZ-8286H ..... ea ..... 14.95  
 '71 – '74 250.  
 ⚙️ ..... D1DZ-8286A ..... ea ..... 20.95  
 '71 – '77 302.  
 ⚙️ ..... D1DZ-8286C ..... ea ..... 17.95



**RADIATOR HOSE CLAMPS**  
 Wire type.  
 1 3/4" ..... AK300 ..... ea ..... 8.00  
 2" ..... AK301 ..... ea ..... 8.95



**RADIATOR OVERFLOW HOSE**  
 Excellent reproduction. Will work on any Ford or Mercury vehicle. Features three raised ribs, like original. 36" long; may require trimming for some applications.  
 ⚙️ ..... C2AZ-9324R ..... ea ..... 10.95



**STAINLESS STEEL ENGINE HOSE CLAMP KIT**  
 A great way to finish your engine dress-up project. The clamps have the FoMoCo logo stamping (except for 5/16" – 3/8" size) and feature a worm gear design for tightening. They are also sized correctly so there is no excessive "tail" overhang. Kit includes: (2) lower radiator – 2 1/8"; (2) upper radiator – 2"; (6) heater and bypass – 5/8"; (6) fuel line and sending unit – 5/16" – 3/8" (not stamped FoMoCo).  
 Fits most 260 / 289 / 302 / 351W.  
 ..... 8287-SBFK ..... kit ..... 29.95



**FAN SHROUDS**  
 '71 – '73 Maverick / Comet V8 without AC.  
 Fiberglass.  
 ⚙️ ..... D0DZ-8146B ..... ea ..... 149.95  
 '71 – '77 Maverick / Comet V8 with A/C.  
 ABS plastic. Looks like the original. This shroud is for cars with air conditioning but will also work on non-air conditioned cars. Includes mount hardware. Made in the USA.  
 ⚙️ ..... D1DZ-8146AKT ..... ea ..... 114.95  
 '75 – '77 Maverick V8 without A/C.  
 Fiberglass.  
 ⚙️ ..... D0DZ-8146B ..... ea ..... 149.95

**NOTE: We have marked with a ⚙️ those parts which also fit corresponding Mercury models, such as Comet.**



**FAN BLADE – 17" V8**

High-quality, OE-style, all-steel fan blade, painted silver. This heavy-duty 35° pitch 17" 6-blade fan will move a large volume of air. Can be used as a replacement fan. Does not include spacers.

**NOTE:** Please check your original fan's diameter, position, and clearance before installing

a new fan. Customer is solely responsible for determining suitability of fan. No payment will be made for engine components damaged due to insufficient fan clearance and / or engine movement. No payment will be made for damaged parts. Fan will be replaced for defects in workmanship or materials ONLY. Always measure carefully and check the condition of the engine mounts.

V8.  
 ..... 9113 .....ea ..... 59.95



**FAN BLADE – 15½"**

4-blade. Diameter: 15½", center hole: 5/8".

**NOTE:** Some 4-blade fans have different diameters; please measure before ordering.

'70 170 M/T without X/C or A/C.  
 ..... C2DZ-8600D .....ea ..... 59.95

**FAN SPACERS**

**Warning:** After fan is mounted, fan needs to have a minimum clearance of 3/4" from radiator, pulleys, hoses and belts. Please check for clearance.



**Original-Style**

2.25" spacer with a painted natural finish. Will fit most applications.

..... 8546-225 .....ea ..... 21.95



**Polished Aluminum**

1.50" with polished aluminum finish. Will fit most Ford and Mercury applications. Required for some small-block and nearly all big-block engines when using a thicker aluminum or 4-row copper/brass radiator. Will not work on vehicles with fan clutch assembly.

**NEW** ..... C4AZ-8546P1 .....ea ..... 22.95



**FAN SPACER BOLT KIT**

Kit includes four 5/16" – 24 x 3¼" bolts and four lock washers.

With 2¾" fan spacer.  
 ... AK1040 .....kit ..... 11.95



**C1DZ-8592C    C5OE-8592    C3OZ-8592    84831**

**THERMOSTAT HOUSINGS**

'70 – '77    170 / 200.  
 Cast aluminum. Includes gasket.  
 ..... C1DZ-8592C .....ea ..... 19.95

'71 – '77    302.  
 Exact reproduction with correct casting numbers.  
 ..... C5OE-8592 .....ea ..... 19.95

Replacement.

Without threaded hole for smog system.  
 ..... C3OZ-8592 .....ea ..... 16.95

With threaded hole for smog system.  
 ..... 84831 .....ea ..... 16.95

**THERMOSTAT HOUSINGS CONTINUED**



**Chrome**

Beautifully chrome-plated thermostat housing featuring an o-ring style seal to prevent water leaks. Precision die-cast for a great fit. Includes gasket and attaching hardware.

'71 – '76. 302.  
 ..... 2662 .....ea ..... 18.95



**AP60720**



**B308**



**4363**

**THERMOSTAT HOUSING GASKET**

With bypass tube hole.

'70 – '77    '70 – '72 170; '70 – '77 200, 250, 302.  
 ..... AP60720 .....ea ..... 2.25

**THERMOSTATS**

**Standard Performance Replacement**

Brass. 180° F.

'70 – '77    '70 – '72 170; '70 – '77 200, 250, 302.  
 ..... B308 .....ea ..... 4.95

**High Performance**

Brass / copper. Designed to resist variations in coolant pressure at high RPMs and open at the desired temperature.

'70 – '77    '70 200; '70 – '73 250; '71 – '77 302.  
 160°.  
 ..... 4363 .....ea ..... 19.95  
 180°.  
 ..... 4364 .....ea ..... 20.95  
 195°.  
 ..... 4365 .....ea ..... 21.95



**WATER PUMP PULLEY**

Single groove.

'70 Maverick 170 M/T without A/C;  
 '71 – '72 Maverick 170 without A/C;  
 '71 – '72 Comet 170.  
 ..... C3OZ-8509B .....ea ..... 59.95



**PW153**



**FP1464**



**5521135**



**WP953**

**WATER PUMPS**

**Motorcraft®**

'71 – '77    302.  
 ..... PW153 .....ea ..... 129.95

**Aftermarket**

'70 – '75    170 / 200 without A/C before 4/12/75.  
 ..... FP1464 .....ea ..... 39.95

'71 – '77    250.  
 ..... 5521135 .....ea ..... 44.95

'71 – '77    302.  
 ..... WP953 .....ea ..... 49.95

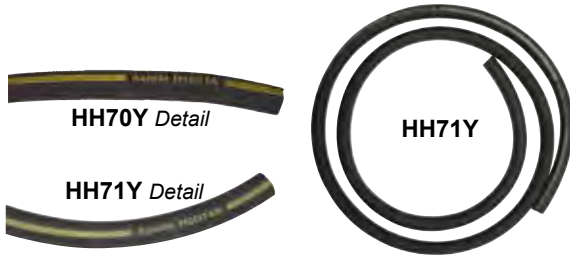

**HEATER HOSES**

Black ribbed hoses with correct Autolite date codes in yellow. 8' long.

'70	.....	HH70Y	.....	ea	.....	24.95
'71 - '77	🔧	.....	HH71Y	.....	ea	24.95



HC209



BPA-18572

**HEATER HOSE CLAMPS**

**Original-Style Tower Clamp**

'70 - '77	🔧	.....	HC209	.....	ea	.....	2.95
-----------	---	-------	-------	-------	----	-------	------

**Bolt-Type Spring Clamp**

'70 - '77	🔧	With 5/8" heater hose.	.....	BPA-18572	.....	ea	.....	2.00
-----------	---	------------------------	-------	-----------	-------	----	-------	------



D4AZ-18495A



74612

**HEATER CONTROL VALVES**

'76 - '77	🔧	After 5/3/76. Genuine Ford.	.....	D4AZ-18495A	.....	ea	.....	39.95
'76 - '77	🔧	All after 5/3/76 with factory air. Import.	.....	74612	.....	ea	.....	19.95

**TIMING CHAIN AND SPROCKET SET**

Features an induction-hardened cast-iron camshaft gear along with a billet steel crank sprocket. The sprocket has three key ways for 4° incremental adjustment (4° advance / retard). Also includes heat-treated, heavy-duty 2-row timing chain. Recommended for mild street applications.



'71 - '77	302	.....	KY2120	.....	set	.....	54.95
-----------	-----	-------	--------	-------	-----	-------	-------

**TIMING CHAIN COVER**

'71 - '77	302.	.....	D3OZ-6019A	.....	ea	.....	69.95
-----------	------	-------	------------	-------	----	-------	-------



**WINDSHIELD WASHER PUMPS AND PUMP KITS**



E0AZ-17664A



E0AZ-17664WH

**Pump Only**

'70 - '77	🔧	Pump	.....	E0AZ-17664A	.....	ea	.....	14.95
		Wiring harness. 2 wire.	.....	E0AZ-17664WH	.....	ea	.....	13.95



**WINDSHIELD WASHER PUMPS AND PUMP KITS CONTINUED**



6501



6601

**Universal Kits**

Includes pump, hose and hardware.

Reservoir not included.	.....	6501	.....	kit	.....	19.95
Reservoir included.	.....	6601	.....	kit	.....	39.95



**WINDSHIELD WASHER RESERVOIR**

White molded plastic. Does not include lid.

'71 - '77	🔧	.....	C9OZ-17618	.....	ea	.....	99.95
-----------	---	-------	------------	-------	----	-------	-------



**WINDSHIELD WASHER HOSE KIT**

Includes tee and hose.

'70 - '77	🔧	.....	D0DZ-17543	.....	kit	.....	12.95
-----------	---	-------	------------	-------	-----	-------	-------



**WINDSHIELD WASHER HOSE CONNECTOR**

F-shaped. Has ports for one 3/16" hose and two 1/8" hoses.

'70 - '71	.....	C7SZ-17A601A	.....	ea	.....	1.95
-----------	-------	--------------	-------	----	-------	------



**WINDSHIELD WIPER MOTOR**

Includes wiring (NOTE: the plug is a replacement, not exactly as original) and an adapter plug for the under-dash harness.

NOTE: Electrical parts are non-returnable once installed. We will replace defective units only.

'70 - '77	🔧	With 2-speed electric wipers.	.....	C6OZ-17508D	.....	ea	.....	99.95
-----------	---	-------------------------------	-------	-------------	-------	----	-------	-------

**STARTER SOLENOIDS**

NOTE: Electrical parts are non-returnable once installed. We will replace defective units only.



6008BLK



6007BLK

**Reproductions**

Black body, stamped with Autolite and Repco logos.

'70 - '74	🔧	Stamped C4AF-11450-A.	.....	ea	.....	39.95
		Stamped C7AF-11450-A2.	.....	ea	.....	39.95

**STARTER SOLENOIDS CONTINUED**



**Replacement**

Import.

'70 - '74 Maverick; '71 - '77 Comet.

⚙️ ..... SW3-AR .....ea ..... 10.95



**STARTER SOLENOID MOUNTING SCREWS**

Set of 4. .... AK266 .....set..... 1.00

**Battery Related**

*NOTE: Electrical parts are non-returnable once installed. We will replace defective units only.*



**AUTOLITE BATTERY COVER**

Fits any group 24F flat-top battery with top terminals. Fits over the battery to give a stock appearance. Black plastic battery top cover with red detailing and molded-in caps. Includes original-style tag for positive terminal.

'70 - '72 ..... 24FCOVER.....ea ..... 49.95



**NEGATIVE BATTERY CABLE SWITCH**

Keeps battery charged without having clocks and accessories drain battery while vehicle is parked for extended periods.

'70 - '77 ⚙️ ..... NEGSW .....ea ..... 10.95

**BATTERY TRAYS AND RELATED**



**Battery Tray**

'70 - '77 small-block V8. Must reuse your old bracket.

..... C6OZ-10732 .....ea ..... 14.95



**Hold-Down Clamps**

**Reproduction**

'70 - '73 ⚙️ ..... D0DZ-10718A.....ea ..... 12.95

'74 - '77 ⚙️ ..... D4MY-10718A.....ea ..... 14.95

**Replacement**

'70 - '77 Steel painted black.

⚙️ ..... C5AZ-10718A .....ea ..... 8.95

Billet aluminum.

⚙️ ..... B10718BL .....ea ..... 40.95



**J-Bolts**

'70 - '77 Requires 2.

⚙️ ..... D0AZ-10756A .....ea ..... 2.50

Stainless steel.

⚙️ ..... D0AZ-10756SS.....pr ..... 16.95

**VOLTAGE REGULATORS**



**Motorcraft®**

Solid-state circuitry with a built-in override to protect against high voltage.

'73 - '77 ..... F0PZ-10316A.....ea ..... 44.95



**Reproductions**

**38 / 42 Amp**

'73 Without A/C.

Blue with silver print and Motorcraft stamp.

⚙️ ..... D3AF-MOTORCRAFT .ea ..... 52.95

**45 / 55 Amp**

'72 - '73 With A/C.

Blue with yellow print and Motorcraft stamp.

⚙️ ..... D2TF-MOTORCRAFT .ea ..... 52.95

'73 With A/C.

Blue with yellow print and Motorcraft stamp.

⚙️ ..... D3TF-MOTORCRAFT .ea ..... 52.95



**Replacement**

Electronic replacement, not OEM.

'70 - '77 4 terminals. Chrome-plated cover. One-year limited warranty - defective unit must be returned in its original box. Made in the USA.

**NEW** ⚙️ ..... 7540 .....ea ..... 24.95

Import.

⚙️ ..... GR540AHD .....ea ..... 18.95



**VOLTAGE REGULATOR MOUNTING SCREWS**

Set of 4. For voltage regulator and starter solenoid.

..... AK266 .....set..... 1.00



**VOLTAGE REGULATOR REPLACEMENT / REPAIR PLUGS AND WIRES**

'70 - '76 4 terminals. Features the correct OEM-style connector, correct gauge and color coded wiring, and a black molded plastic radio suppressor connector.

⚙️ ..... C3SZ-10316RP.....ea ..... 7.95

'70 - '77 Replaces OEM socket. Has 6 wires coming from it.

⚙️ ..... 85124 .....ea ..... 7.95



**REMANUFACTURED ALTERNATOR**

65 amp single pulley.

**NOTE:** There is a core fee of \$35.00 that is refundable upon return of the old unit and must be returned with box in which remanufactured unit was shipped.

'72 - '77 ..... KY7072 .....ea ..... 89.95

Core fee ..... KY7072CORE..... 35.00

**NEW AFTERMARKET ALTERNATORS**

Premium quality. Includes pulley and fan. 1-year warranty from the manufacturer. Defective alternator must be returned in its original box.



**70 Amp**

**Standard**

'70 - '77 Fits most vehicles with OE small-case alternators. For use with external voltage regulator. Chrome finish.

🔧	PA70	ea	169.95
🔧	PA70-N	ea	129.95

**1 Wire**

Features only 1 wire from the alternator to the battery, eliminating your externally-mounted voltage regulator.

'70 - '77 Fits most vehicles with OE small-case alternator with ear holes 6.875" center-to-center. Chrome finish.

🔧	PA70-1	ea	199.95
---	--------	----	--------

**100 Amp - 1 Wire**

Features only 1 wire from the alternator to the battery, eliminating your externally-mounted voltage regulator.

'70 - '77 Fits most vehicles with OE small-case alternator with ear holes 6.875" center-to-center. Chrome finish.

🔧	PA100-1	ea	219.95
🔧	PA70-1N	ea	129.95

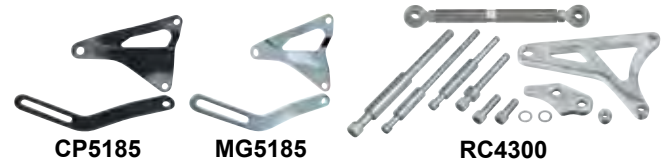

**ALTERNATOR BRACKET SETS**

Includes adjustment arm and top bracket.

'70 - '77 289, 302, 351W. Black. CP5185 set 22.95

'70 - '77 302. Chrome. MG5185 set 24.95  
Adjustable. Made of high-quality, lightweight, T-6061 billet aluminum with a polished finish. Includes mount brackets, adjustable rod, mounting bolts, and spacers.

**NOTE:** Professional installer is highly recommended; no instructions are included.



RC4300	kit	46.95
--------	-----	-------

**C5AZ-10344K**



**C5AZ-10344L**

**ALTERNATOR PULLEYS**

'70 - '73 2.62" single. For use with single-pulley alternators. Stamped zinc dichromate gold.

🔧	C5AZ-10344K	ea	19.95
---	-------------	----	-------

'70 - '73 2.62" double. For use with double-pulley alternators. Solid steel - quieter and more durable than aluminum.

🔧	C5AZ-10344L	ea	24.95
---	-------------	----	-------



**C7AL-644**



**D0OE-10A370B**

**ALTERNATOR PULLEY NUT AND WASHER**

Gold zinc.



'70 - '77	🔧	C7AL-644	ea	2.95
-----------	---	----------	----	------

**ALTERNATOR SPACER**

Silver. 1.0" O.D., 1.44" long.



'71 - '73	302.	🔧	D0OE-10A370B	ea	11.95
-----------	------	---	--------------	----	-------



**ALTERNATOR HARNESS**

Runs from the alternator to the voltage regulator and the battery.

**NOTE:** Electrical parts are non-returnable once installed. We will replace defective units only.

'71	.....	D1OZ-14305B	ea	54.95
-----	-------	-------------	----	-------

**A/C Components**



Typical Dryer

**A/C FILTER DRYER REBUILD SERVICE**

Send in your original A/C filter dryer, and we will rebuild it for you. Dryer is cut open and old filters and drying agent are removed, then it gets bead-blasted inside and out, and new filters are installed. It is then TIG welded back together and pressure tested, then capped and painted. Backed by a 90-day manufacturer's warranty against leaks.

When ordering, please specify R-12 or R-134a refrigerant, and year, make, and model of your vehicle. Call our rebuild department to place an order or for any questions concerning our rebuilds. You must supply a rebuildable core when ordering.

Please allow 3 weeks plus shipping time for rebuild.

'70 - '73	🔧	FILDRYRB	ea	179.95
-----------	---	----------	----	--------



**511PLM**

Shown Mounted



**511PLM**



**482FRDP**

**A/C COMPRESSOR COVER PLATES**

Fits all York or Tecumseh A/C compressors. Includes mounting hardware.

Plain polished	480PLP	ea	49.95
Plain matte finish	511PLM	ea	49.95
Ford logo polished	482FRDP	ea	49.95
Ford matte finish	513FRDM	ea	49.95



**A/C COMPRESSOR CRANK SHAFT SEAL KIT**

'70 - '71	With York compressor.	🔧	C9AZ-19655B	ea	26.95
-----------	-----------------------	---	-------------	----	-------



**A/C COMPRESSOR SWITCH AND BRACKET**

Compressor brush and bracket.

'72 Maverick with hang-on A/C.  
..... C8SZ-2979A .....ea ..... 36.95



**ADJUSTABLE A/C IDLER PULLEY AND BRACKET**

'72 - '77 302 with factory integral A/C.  
..... D8OZ-8678A .....ea ..... 89.95



14-105



14-106

**A/C SERVICE VALVES**

O-ring fitting for hoses and o-ring seal at compressor.

'70 - '73 With A/C.  
#8 small valve (discharge line).  
..... 14-105 .....ea ..... 29.95  
#10 large valve (suction line).  
..... 14-106 .....ea ..... 29.95



04-3131



04-3124



04-3132

**STARTERS - REMANUFACTURED**

'70 - '77 '70 - '72 Maverick / Comet 170; '70 - '77 Maverick / Comet 200 M/T before 12/13/76; '71 - '77 Comet 250 M/T before 2/1/77.  
..... 04-3135 .....ea ..... 69.95  
Core fee ..... 04-3135CORE ..... 25.00  
'70 - '77 200 A/T before 12/13/76; '71 - '77 Comet 200 A/T before 12/13/76.  
..... 04-3131 .....ea ..... 79.95  
Core fee ..... 04-3131CORE ..... 25.00  
'70 - '77 '70 - '76 250 / 302 A/T; '71 - '76 Comet 250 / 302 A/T; '77 Comet 250 A/T before 2/1/77.  
..... 04-3124 .....ea ..... 89.95  
Core fee ..... 04-3124CORE ..... 15.00  
'71 - '76 302 M/T.  
..... 04-3132 .....ea ..... 79.95  
Core fee ..... 04-3132CORE ..... 25.00  
'77 250 / 302 A/T after 2/1/77; '77 Comet 302 A/T after 2/1/77.  
..... 04-3153 .....ea ..... 49.95  
Core fee ..... 04-3153CORE ..... 25.00  
'77 302 M/T after 3/1/77.  
..... 04-3154 .....ea ..... 49.95  
Core fee ..... 04-3154CORE ..... 20.00



**NEW STARTER**

Comes clocked from the manufacturer to fit most applications. The mounting block can be re-clocked as required. Includes spacer ring and instructions. 90-day manufacturer's warranty for street applications.

'70 - '77 302 with A/T or 5-speed M/T.  
..... 9603FX .....ea ..... 199.95



9603



9503



**STARTERS - NEW**

High torque. Geared.

'70 - '77 302 A/T or 5-speed M/T.  
180 foot-pound starter. Has power for up to 12:1 compression with no heat soak problems, clears the oil pan and has a 4.4:1 gear reduction ratio. Includes billet aluminum adapter block, mounting bolts, and instructions. 1-year manufacturer's warranty for street applications. Weighs 10.5 lbs.  
..... 9603 .....ea ..... 229.95  
'75 - '76 302 A/T or 4- or 5-speed M/T.  
200 foot-pound starter. Has a 4.4:1 gear reduction ratio and cranking power for up to 18:1 compression. It clears all headers and oil pans where the original starter worked. Comes with billet aluminum adapter block, mounting bolts, dyno test results, and instructions. Weighs approximately 8 lbs.  
..... 9503 .....ea ..... 229.95

**OIL PANS**



**Painted Black**



Direct fit replacement made from strong stamped steel and painted black. Includes drain plug.

'70 - '77 250.  
**NEW** .....

..... C9DZ-6675A .....ea ..... 169.95



C4DZ-6675B



D0OZ-6675

**Painted Blue**

'70 - '72 170, 200.  
..... C4DZ-6675B .....ea ..... 149.95  
'71 - '77 302.  
..... D0OZ-6675 .....ea ..... 79.95



**"Cal Custom" Finned**

Aluminum. Fully polished. Includes magnetic drain plug. For engines with front oil sump.

'71 - '77 302.  
..... D0OZ-6675AL .....ea ..... 149.95



D6TZ-6730R



15

**OIL PAN DRAIN PLUGS**

1/2" - 20 stud. Includes gasket.

**Reproduction**

5/8", painted blue.  
'70 - '77 ..... D6TZ-6730R .....ea ..... 2.95

**Replacement**

'70 - '77 Magnetic. Accumulates metal particles found in the oil, preventing possible damage to the engine.  
..... 15 .....ea ..... 13.95



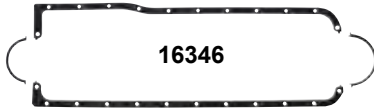

16346



OS13260C

**OIL PAN GASKETS**

**Rubberized Fiber**

Quality fibrous material with a rubber binder. Withstand temperatures to 350° F. Includes LH and RH gaskets and front and rear seals.

'70 - '77	170, 200.		
		16346	set..... 18.95
'71 - '77	302.		
		OS13260C	set..... 19.95

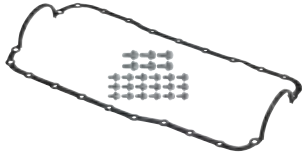

**Ultra-Seal™ 1-Piece**

Cellulose / nitrile composition coated with black latex, which helps seal along minor irregularities in the oil pan rail. Excellent replacement for OE as well as high performance applications. Gasket is 1 piece with

molded front and rear seals. Kit includes 1-piece gasket and bolts.

'71 - '77	302.		
		6683	kit..... 55.95



**OIL PAN BOLT KIT**

Zinc-plated, grade 5, hex flange-head bolts. Kit includes (6) 5/16" -18 x 3/4" and (18) 1/4" - 20 x 1/2" bolts.

'71 - '77	302.		
		6087	kit..... 17.95



**OIL PUMP SCREEN ASSEMBLY**

Oil pump screen and tube assembly. Includes a gasket.

For oil pan, see part #D00Z-6675 on the previous page.

'71 - '77	302.		
		68S	ea ..... 19.95



FL-1A



M6731FL1A

**OIL FILTERS**

'70 - '77	Standard.		
	Motorcraft.		
		FL-1A	ea ..... 6.95
	High performance.		
	Ford Racing Performance Parts. Genuine Ford.		
		M6731FL1A	ea ..... 22.95



**Chrome**



This show-quality, hand-polished chrome filter exceeds all OEM specifications and removes engine damaging particles. Features roll-formed threads for a precise spin-on fit; triple-process chrome that won't peel or flake; pleated element design to increase filtering area; steel backplate for added protection against pressure surges; gasket retainer and sealing gasket to prevent leaks; cured resin-impregnated element to remove harmful particles; and a rolled-seam housing that withstands over 200 PSI.

Replaces filter #FL-1A.

'71 - '77	V8 with spin-on filter.		
		22400	ea ..... 29.50



**OIL DIPSTICK**

'70 - '74	'70 - '72 170; '70 - '74 200.		
		C2DZ-6750B	ea ..... 29.95



5723



57235

**OIL DIPSTICKS AND TUBES**

'70 - '77	302.		
	<b>Stock Style</b>		
	Chrome handle stick, tube, and adjustable bracket. Chrome finish on the stick itself will not flake. Markings match original equipment.		
		5723	ea ..... 18.95

	<b>Aftermarket Style</b>		
	Billet dipstick, tube, and adjustable bracket. Features a tube base made to OE specifications for a correct fit.		
		57235	ea ..... 24.95

**OIL PRESSURE SENDING UNIT**

'70 - '77			
		SW1311	ea ..... 13.95

**OIL FILLER CAPS**



EC-31FB

**AUTOLITE**



D1AZ-6766A

**Black**

'70	Closed emission. Features FoMoCo block logo on top.		
		EC-31FB	ea ..... 21.95
'70 - '77	'70 - '72 170; '70 - '77 200, 302. Twist-on. Autolite logo stamped on top. Includes elbow and 2 grommets.		
		D1AZ-6766A	ea ..... 29.95



C5ZZ-6766D

**AUTOLITE**



D1AZ-6766C

**Chrome**

'70	170, 200, 250. Features FoMoCo block logo on top.		
		C5ZZ-6766D	ea ..... 29.95
'70 - '77	'70 - '72 170; '70 - '77 200, 302. Twist-on. Autolite logo stamped on top. Includes elbow and 2 grommets.		
		D1AZ-6766C	ea ..... 35.95



**Shelby Style**

Fits most valve covers that accept push-on oil cap. Triple-chrome-plated reproduction of the 1965-67 Shelby Mustang oil cap. Features tube for cap-to-air cleaner hose and FoMoCo script logo.

		C5ZZ-6766E	ea ..... 35.95
--	--	------------	----------------

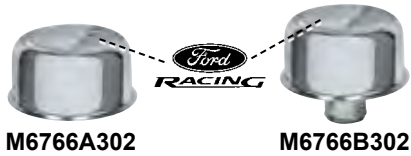

**FORD RACING OIL FILLER CAPS**

Ford Racing logo on top.

- '70 - '77 Small-block with open crankcase.
- Twist-on type ..... M6766A302 .....ea ..... 14.95
- Push-in type ..... M6766B302 .....ea ..... 14.95



**BILLET REPLACEMENT OIL FILLER CAPS**

- '70 - '77 Fits valve covers with a plug-in style 1/4" filler hole.
- ..... 17385 .....ea ..... 15.95
- Fits valve covers with a twist-lock type filler hole. Includes gasket.
- ..... 43105 .....ea ..... 14.95



**REPLACEMENT CHROME OIL FILLER CAPS**

For use with small-block valve covers on page 54.

- Push-on ..... 2060 .....ea ..... 10.95
- Twist-on ..... 4281 .....ea ..... 7.95



**OIL FILLER CAP ADAPTER**

Allows you to use a push-on type oil filler cap with a twist-on type filler hole. Includes gasket.

- ..... C5AZ-6A868A .....ea ..... 14.95



**HARMONIC BALANCERS**

- '70 - '77 '70 - '72 Maverick 170 with single groove;
- '70 Maverick 200;
- '71 - '73 Maverick 200 with single groove;
- '76 - '77 Maverick 200 with single groove;
- '71 Comet 170 / 200;
- '72 Comet 170 / 200 with single groove;
- '73 - '75 Comet 200 with single groove;
- '76 - '77 Comet 200 without A/C.
- 5 29/32" diameter, 3 bolt.
- ..... C2DZ-6312A .....ea ..... 99.95
- '71 - '77 302.
- 6 1/2" diameter, 4 bolt.
- ..... D2OZ-6316A .....ea ..... 99.95



**HARMONIC BALANCER REPAIR SLEEVES**

- '70 - '77 '70 - '72 170; '70 - '77 200.
- ..... HB3121 .....ea ..... 4.95
- '71 - '77 302.
- ..... HB3124 .....ea ..... 4.95



**HARMONIC BALANCER / STEERING WHEEL PULLER KIT**



When removing steering wheels and harmonic balancers, this 13-piece kit is what you need. Drop-forged, heat-treated steel. Alloy steel center shaft with floating, removable swivel applies even pressure, preventing damage.

Kit includes (1) yoke, (1) threaded shaft, (1) floating swivel, (2) 5/16" x 4" (7.9 mm x 101 mm) bolts, (2) 1/4" x 3" (6.3 mm x 76 mm) bolts, (3) 1/4" x 2" (6.3 mm x 50 mm) bolts, (3) 5/16" x 2" (7.9 mm x 50 mm) bolts and a durable blow-molded plastic case

Manufacturer's warranty against defects in materials and workmanship for a period of one year from the date of original retail purchase.

- ..... KRA100 .....kit ..... 29.95



**REPLACEMENT CARBURETORS**

New aftermarket replacements. Mounting gasket included. Does not include instructions. Imported.

90-day warranty from date of purchase.

**NOTE:** Professional installation recommended.

- '70 - '77 250.
- Carter-type YFA 1-barrel carburetor.
- Electric choke ..... 1BBL-9510EC .....ea ..... 139.95
- Vacuum choke ..... 1BBL-9510VC .....ea ..... 139.95
- '71 - '77 302.
- 2-barrel model 2100 carburetor. 300 CFM, electric choke.
- ..... 2100 .....ea ..... 159.95



**HOLLEY® CARBURETORS**

- '70 - '77 2/V, 350 CFM. Manual choke.
- Designed to be a stock performance replacement. Features a 30 cc accelerator pump, one timed (spark) port, and one PCV port. Includes gasket, hardware, and instructions.
- NOTE:** Will not work with automatic overdrive.
- ..... HC7448 .....ea ..... 399.95
- '70 - '77 2/V, 500 CFM. Electric choke.
- Excellent upgrade from the original 2/V carburetor. Features optimized street calibrations, 3 vacuum ports for all necessary vacuum accessories, factory preset electric choke, built-in fuel filters, and a 3/8" fuel line connection. Its fuel metering system provides precise fuel control for great low-end torque and awesome acceleration. Compatible with A/T kick-down linkage (additional parts may be required). Manufacturer's limited lifetime warranty. Instruction manual included. Polished finish.
- ..... HC80500 .....ea ..... 394.95
- '70 - '77 V8. 4/V, 600 CFM.
- Manual choke with power valve blow-out protection and vacuum secondaries. Includes a fast idle adjustment and vacuum PVC spark ports, carburetor-to-engine gasket, air cleaner gasket, 2 fuel fittings with gaskets, and instructions. Classic finish ..... HC1850C .....ea ..... 404.95



**FAST IDLE CAM LEVER**

For use on Autolite carburetors.

Straight arm ..... C4AZ-9F577B .....ea ..... 9.95

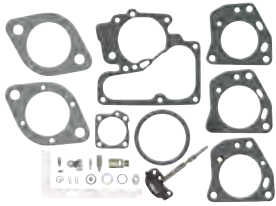

**1BBL-YFKIT**

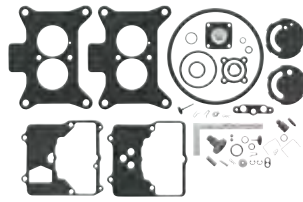

**2100KIT**

**CARBURETOR REPAIR KITS**

- '70 - '74 170 / 200 with model YF Carter 1/V carburetor.  
 ..... 1BBL-YFKIT .....kit ..... 29.95
- '70 - '74 With model 2100 2/V Ford / Autolite / Motorcraft carburetor.  
 ..... 2100KIT .....kit ..... 24.95
- '71 - '74 **NEW** 302 with model 4300 4/V carburetor (specification I.D.-A).  
 ..... 4300KIT .....kit ..... 29.95



**EFI-2300G**



**EFI-4150S**

**HOLLEY® SNIPER EFI THROTTLE BODY CONVERSION KITS**



Self-tuning throttle body conversion kits with hand-held EFI monitors. Put an end to cold-start issues, hesitations, vapor lock, and flooding that a carburetor can cause. Bolt-on carburetor replacements.

Features:

- throttle body-mounted ECU – no extra boxes to mount
- only 4 wiring connections required! (battery +, battery -, switched ignition, and RPM)
- internal fuel pressure regulator that eliminates the hassle of plumbing an external fuel pressure regulator (preset to 58.5 PSI)
- integrated ignition timing control and coil driver
- high-resolution full-color touchscreen for Initial Setup, Tuning, and Gauge displays
- simple Calibration Wizard (answer a few questions about the engine, and it creates the base map, then starts tuning on its own) – NO laptop required)
- self-tuning ECU – no need to be a computer / tuning wiz to have EFI
- genuine Bosch LSU 4.9 Wideband oxygen sensor that provides real-time Fuel Map Learn
- OEM-style TPS/IAC and fuel pressure regulator, for years of dependable service
- clamp-on oxygen sensor kit for 2.25" exhaust that ensures a leak-free oxygen sensor installation, with stainless steel T-bolt clamps and a stainless steel (weldable) oxygen sensor flange

Installation instructions included.

**NOTE:** Not applicable for Ford or Mercury A/T kick-down.

- 2/B 580 CFM supports up to 350 hp with two 100 lb/hr injectors. Equipped with C4 / C6 Ford transmission kick-down lever.  
 Gold finish ..... EFI-2300G .....kit ..... 899.95  
 Shiny finish ..... EFI-2300S .....kit ..... 849.95
- 4/B 800 CFM supports up to 650hp with four 100 lb/hr injectors. Dual-pattern, designed to fit 4150 flange- and spread-bore manifolds (use of a spread bore sealing plate is recommended).  
 Gold finish ..... EFI-4150G .....kit ..... 999.95  
 Shiny finish ..... EFI-4150S .....kit ..... 999.95



**DISTRIBUTOR VACUUM CONTROL – N.O.R.S.**

**NOTE:** There is some light oxidation on some units, but this will not affect their function.

- '70 - '71 Maverick 170 / 200 / 250 A/T, M/T or M/T with IMCO; '71 Comet 170 A/T or M/T.  
 ..... D2PZ-12370A .....ea ..... 34.95



**UNIVERSAL THROTTLE RETURN SPRING**

- ..... 329013 .....ea ..... 2.50

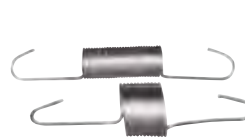

**4700**



**4708**

**UNIVERSAL THROTTLE RETURN SPRING KIT AND BRACKET**

Triple chrome plated.

**Spring Kit**

Use the dual springs for additional return response needed with any high performance carburetor.

- ..... 4700 .....kit ..... 12.95

**Spring Bracket**

Designed for multiple mounting points and easy to install. For springs, see part #4700 above.

- ..... 4708 .....ea ..... 6.95



**UNIVERSAL THROTTLE RETURN BRACKET AND SPRING KIT**



The bracket is carburetor base mount and the dual springs provide additional return response needed with any high-performance carburetor. Polished stainless steel bracket and springs. Installation instructions included.

**NOTE:** Does accept transmission kick-down cable.

- ..... KRA-4000 .....kit ..... 39.95



**SP2418**



**SP24283**

**UNIVERSAL THROTTLE CABLE BRACKETS**

Easy to install. Features adjusting screw to maintain proper alignment of throttle cable. Chrome finish.

- All 2/B and 4/B.  
 Without A/T kick-down cable bracket.  
 ..... SP2418 .....ea ..... 19.95
- With A/T kick-down cable bracket.  
 ..... SP24283 .....ea ..... 19.95

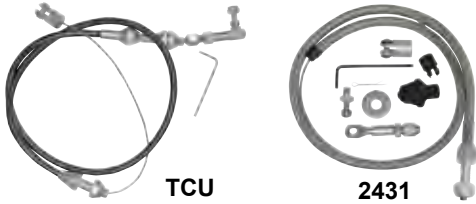

**THROTTLE CABLES – UNIVERSAL**

**24"**

These are not a direct factory replacement. May require modification.

'70 – '77	Stock-style cable.	
	TCU.....	ea ..... 58.50
	Braided cable.	
	TCHT.....	ea ..... 79.95

**36"**

Stainless braided housing. Kit contain all hardware and fasteners.

	5659.....	kit..... 49.95
	1/4" – 20 thread on connection.	
	2431.....	kit..... 39.95



**ACCELERATOR CABLE**

Goes from the accelerator pedal to the carburetor. 20" long.

'75 – '77	302.	
	D7DZ-9A758B.....	ea ..... 39.95



**TYPHOON INTAKE MANIFOLDS**

'70 – '77	302.	
	Polished.	
	Includes hardware. Gasket sold separately (see part #D1AZ-9433B below).	
	54000.....	ea ..... 269.95
	Satin finish.	
	54001.....	ea ..... 225.00



**INTAKE MANIFOLD GASKET SET**

Includes (1) intake front seal, (1) intake rear seal, (1) distributor mounting "O" ring and (2) intake manifold gaskets.

'71 – '77	302.	
	D1AZ-9433B.....	set..... 16.95



**EDELBROCK® INTAKE MANIFOLD AND GASKETS**

**Manifold**

Made in the USA.

'70 – '77	302 without EGR....	2121.....	ea ..... 289.95
-----------	---------------------	-----------	-----------------

**Manifold Gaskets**

For use with intake manifold part #2121 above.

'70 – '77	.....	7220.....	set..... 21.95
-----------	-------	-----------	----------------



**INLINE FUEL FILTERS**

'70 – '77	6- and 8-cylinder with screw-in filter in front of carburetor.	
	Fine thread.....	FG14C.....ea ..... 3.95



**Chrome Aluminum High-Performance Fuel Filter**

Adds a finishing touch to your engine compartment. Features a replaceable element and includes 2 chrome-plated clamps for installation. Not for fuel injected systems. Fits 3/8" fuel hose.

	6153.....	ea ..... 22.95
--	-----------	----------------



**FUEL PUMPS**

**6-Cylinder**

'70	170, 200.....	M6399.....	ea ..... 36.50
'71 – '74	Maverick 170, 200, 250; '73 – '74 Comet 200, 250.		
	.....	M6092.....	ea ..... 44.95
'75	200, 250.		
	.....	M6681.....	ea ..... 44.95

**8-Cylinder**

'71 – '75	302 through early '75.		
	.....	M6588.....	ea ..... 29.95
'75 – '77	302 from late '75.		
	<b>NOTE:</b> For '75 models, make sure the line hookup on this pump is the same as the pump you are replacing.		
	.....	M6750.....	ea ..... 39.95



**HOLLEY® FUEL PUMP**

Has a 7½ PSI pre-set shut-off, 80 gal./hour capacity, and its solid construction is great for continuous high-RPM operation. Can be rotated for various plumbing designs. Includes gasket.

**NOTE:** This product is not legal for sale or use in California except on pre-1966 model vehicles.

'70 – '77	302.....	12833.....	ea ..... 119.95
-----------	----------	------------	-----------------



**ELECTRONIC FUEL PUMP – UNIVERSAL**

Fits all carburetor-equipped cars. Easy to install. Per instructions: 12 volt, 4–7 PSI low amp (2 amps at maximum). Compatible with all fuels and additives. Eliminates vapor lock. Solid-state, 2-wire design. Self-priming.

'70 – '77	.....	PRO12S.....	ea ..... 34.95
-----------	-------	-------------	----------------



**FUEL PUMP BLOCK-OFF PLATE**

This chrome plate is used block the fuel pump mounting hole on the engine block when a vehicle is upgraded from a mechanical fuel pump to a electronic, in-tank pump. Stamped with the Ford oval logo. Mounting hardware and gasket not included.

'71 - '77 302.  
 ..... M9351A302 ..... ea ..... 12.95



**UNIVERSAL FUEL LINE HOSE AND CLAMP KIT**

Kit includes 36" of hose, 8 spring clamps, and 8 keystone clamps.

With 5/16" fuel hose.  
 ..... HHK0001 ..... kit ..... 11.95



**FUEL LINE-TO-FENDER APRON GROMMET**

Rubber with 3/8" fuel line hole. Requires 1 per vehicle.

'70 - '77 ..... D0DZ-9K288A ..... ea ..... 5.95



**D0DZ-9275A**

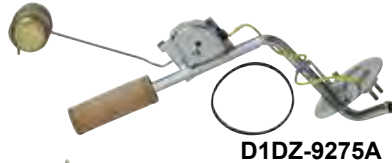

**D1DZ-9275A**



**D6DZ-9275A**

**FUEL SENDERS**

Features stainless steel construction which helps reduce corrosion problems. Includes gasket and filter. 3/8" inlet tube.

**NOTE:** 1-year manufacturer's warranty against manufacturer defects as long as the unit is not modified in any manner. Any damaged or defective unit should be sent back to Auto Krafter's, where it will be forwarded to our manufacturer for quality-control inspection. A replacement unit will be provided at no charge, plus shipping.

'70 ..... D0DZ-9275A ..... ea ..... 79.95  
 '71 - '74 ..... D1DZ-9275A ..... ea ..... 79.95  
 '75 - '77 '75 6-cylinder after 5/1/75; '75 8-cylinder after 3/17/75; '76 - '77 all.  
 ..... D6DZ-9275A ..... ea ..... 79.95



**FUEL SENDER LOCKING RING REMOVAL TOOL**



Works on '60 - '85 Ford and Mercury vehicles with 2 1/8" I.D. locking ring. Enables easier removal and installation of the locking ring when replacing the fuel sending unit. Handle provides additional leverage without risk of damage that could otherwise happen when using a hammer and punch. Correct tooth pattern allows for full engagement of locking ring circumference. Made of high-quality steel.

..... TL-FSU01 ..... ea ..... 14.95



**FUEL SENDER LOCKING RING**

'70 - '77 ..... C0AZ-9A307B ..... ea ..... 5.95

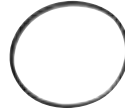

**FUEL SENDER GASKET**

'70 - '77 Maverick; '71 - '72 Comet.  
 ..... C0AF-9276A ..... ea ..... 1.50



**FUEL SENDER FLOAT**

*New, improved design.* Brass end with solid core float. Unlike the hollow type, this won't sink due to pinholes. 2" long. 1 3/16" O.D. x 1 5/64" I.D. groove where sender arm clips onto float.

**NOTE:** Float may be smaller where it clips on than your original; may require slight modification to sender arm.

'70 - '77 ..... 15309 ..... ea ..... 6.95



**D1AZ-9A011A**



**D1FZ-9A011A**

**FUEL SENDER FILTERS**

Use with 3/8" tube ..... D1AZ-9A011A ..... ea ..... 9.95  
 Use with 5/16" tube ..... D1FZ-9A011A ..... ea ..... 9.95



**FUEL VAPOR SEPARATOR VENT**



This metal vent is a factory-correct reproduction that installs inside the cutout located on top of the fuel tank and connects to vapor line of the emissions equipment system. Includes gasket and lock ring.

'71 - '75 ..... D1AZ-9B328A ..... ea ..... 44.95



**FUEL VAPOR VALVE AND GROMMET**

Necessary for installation of fuel tank #D7DZ-9002C (next page) in a '71 - '75 Maverick, because the emission hole in the original tank was larger than the hole in the D7DZ-9002C tank.

Also, if you are installing D7DZ-9002C in a '76 - '77 car, you may want to purchase them because the old valve is very difficult to remove from the old tank without damaging it.

**Valve and Grommet**

'71 - '77 ..... E7DZ-9B593VG ..... ea ..... 39.95

**Grommet Only**

'76 - '77 ..... F6TZ-9B076AA ..... ea ..... 9.95



**D0DZ-9002A**



**D3DZ-9002A**

**STEEL FUEL TANKS**



**NOTE:** There is a \$10.00 boxing fee for this item.

**NOTE:** Due to its size, additional shipping charges apply.

'70 Without EV/EM.  
 16 gallon ..... D0DZ-9002A ..... ea ..... 299.95  
 '71 - '74 15 gallon.  
 ..... D3DZ-9002A ..... ea ..... 299.95

**Boxing Fee**

**Oversize**

**Truck Freight**



**STEEL FUEL TANKS CONTINUED**

'75 - '77 19 gallon.  
**NOTE:** This tank will also work on '71 - '75, but you **MUST** use Fuel Tank Straps #ST99 (see below) to install this tank on '71 - '75, because these models did not have a 19 gallon tank and the original straps are too short. For '71 - '73, you may have to pull the valance away from the tank slightly.

There is no fuel sender available for this tank. You will have to re-use your old one, which on '76 - '77 is fine, but on '71 - '75 your gauge will not register correctly since '71 - '75 had smaller tanks.

This tank has a smaller emission hole than the '71 - '75 tank, so if you are installing this tank in a '71 - '75 car you will need a vapor valve and grommet (part #E7DZ-9B593VG - previous page). For grommet only, see part #F6TZ-9B076AA (previous page). If you are installing this tank in a '76 - '77 car, you may also want to purchase the vapor valve and grommet, because the old valve and grommet are very difficult to remove without damaging them.

..... D7DZ-9002C ..... ea ..... 219.95

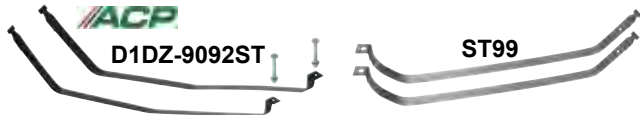

**FUEL TANK STRAPS**

'71 - '74 For use with fuel tank #D3DZ-9002A only (previous page).

**NEW** ..... D1DZ-9092ST ..... pr ..... 44.95

'75 - '77 For use with fuel tank #D7DZ-9002C only (see above).

..... ST99 ..... pr ..... 44.95



**FUEL TANK STRAP ANTI-SQUEAK KIT**

Has two 36" long x 1 1/2" wide strips of waterproof barrier material. Can be used on other applications, just check the length of you straps.

'70 - '77 ..... D1DZ-9A058 ..... ea ..... 6.95

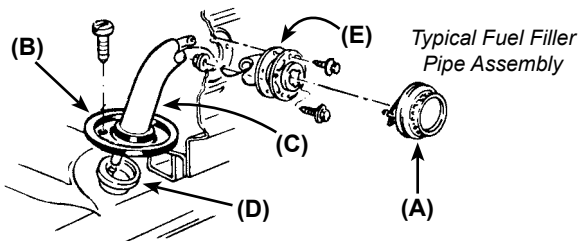

**FUEL FILLER CAPS (GAS CAPS) (A)**

'70 - '77 Maverick except California emission. Deluxe non-locking, vented. Chrome-plated die-cast housing with a black plastic Maverick logo insert with silver accents.

**NOTE:** This cap was used on the '76 - '77 Maverick with the Luxury Decor option, but will fit '70 - '75. The only difference is that the '70 - '75 cap had the steer head but not the "Maverick" script.

**NEW** ..... D5DZ-9030 ..... ea ..... 129.95



**FUEL FILLER CAPS (GAS CAPS) CONTINUED**

'71 - '77 Non-locking, vented.  
 ..... RG734 ..... ea ..... 39.95

'71 - '77 '71 - '76 Maverick; '71 - '77 Comet. Locking, emission control type. Includes keys.  
 ..... RG759 ..... ea ..... 29.95

**FUEL FILLER PIPE-TO-TRUNK FLOOR SEAL (B)**

'71 - '77  
 ..... D1ZZ-9008 ..... ea ..... 28.95



**FUEL FILLER PIPES (C)**

Steel.  
 '70 ..... D0DZ-9034A ..... ea ..... 49.95  
 '71 - '74 ..... D1DZ-9034A ..... ea ..... 59.95



**FUEL FILLER PIPE-TO-TANK HOSE**

'70 - '77 ..... D1DZ-9047 ..... ea ..... 9.95

**FUEL TANK-TO-FILLER PIPE SEALS (D)**

'71 - '75 Maverick before 5/1/75; '72 Comet.  
 ..... D1ZZ-9072 ..... ea ..... 19.95  
 '75 - '77 Maverick / Comet after 5/1/75.  
 ..... E1AZ-9072B ..... ea ..... 19.95

**FUEL FILLER PIPE NECK-TO-BODY GASKET (E)**

'70 - '77  
 ..... D1DZ-9076A ..... ea ..... 1.00



**CHROME 14" HI-PO STYLE AIR CLEANERS WITH ELEMENTS**

Features a performance type replacement filter and a custom base designed to fit stock Autolite and Motorcraft carburetors.

**6-Cylinder**

'70 - '73 170, 200, 250.  
 ..... C4DZ-9600W ..... ea ..... 39.95

**8-Cylinder**

Exact reproduction ..... C5ZZ-9600W ..... ea ..... 44.95  
 Aftermarket ..... MRG1480 ..... ea ..... 39.95

NEW

**CHROME 14" HI-PO STYLE AIR CLEANERS WITH ELEMENTS CONTINUED**



**Cobra Style**

Hi-Po style air cleaner featuring raised lettering "COBRA" on a polished chrome lid. This 14" assembly includes the lid, correct orange air filter element, painted blue base with 5" mounting hole and 1/4" - 20 stud. The lid also features dimpled recess for wing nut and rounded edge.

..... S1MS-9600COBRA .....ea ..... 49.95



**Replacement Element**

..... MRG1480A .....ea ..... 18.95

**CHROME AIR CLEANERS - UNIVERSAL**



**1/B or 2/B**

Chrome-plated top and steel base. 6 1/2" diameter. Includes filter, adapter, and hardware kit.

For vehicles with 2 5/16" or 2 5/8" diameter neck.

Low riser 2" high..... 1491 .....ea ..... 32.95  
High riser 3 1/4" high..... 1490 .....ea ..... 29.95



**Replacement Filters for Above Air Cleaners**

For cleaner #1491..... 1486A.....ea ..... 13.95  
For cleaner #1490..... 1485A.....ea ..... 9.95



**2/B**

Classic design with chrome-plated top. Includes filter, gasket, hardware, and PCV adapter.

For vehicles with 2 5/8" or 3 1/16" diameter neck.

.....KY9798 .....ea ..... 34.95

**Replacement Filter for Above Air Cleaner**

10" x 2" ..... 6479 .....ea ..... 15.95

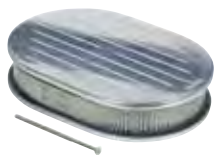

**HOLLEY® SMALL OVAL AIR CLEANER ASSEMBLY**

NEW

Aftermarket cast-aluminum oval air cleaner with a billet-look, ball-milled top. This low-profile oval air cleaner is 11 7/8" long x 8 3/8" wide x 3 1/4" tall. Fits carburetors with 5 1/8" (5.125") diameter neck. Assembly includes top, oval filter, bottom, and all hardware necessary for installation.

**NOTE:** Not legal for sale or use in California on any pollution-controlled motor vehicles. .... 120-141 .....ea ..... 149.95



**BILLET ALUMINUM OVAL AIR CLEANER ASSEMBLY**

Aftermarket polished aluminum oval air cleaner with a billet look and ribbed top. This low-profile oval air cleaner is 15" long x 8 1/2" wide x 3" tall. Fits single-carburetor engines with 5 1/8" (5.125") diameter neck. Assembly includes top, oval filter, bottom, and all hardware necessary for installation. Filter height is 2".

**NOTE:** Not legal for sale or use in California on any pollution-controlled motor vehicles. .... 15640 .....ea ..... 189.95



**OVAL SINGLE 4/B AIR CLEANER ASSEMBLY**

Assembly includes top, oval filter, bottom, and all necessary hardware for installation. Ribbed top does not have cut-out for emblem. Cast aluminum as original for 1961-67 cars but will fit other cars with a single 4/B carburetor.

With 4/B carburetor.

..... C3AZ-9600P4 .....ea ..... 229.95

**Oval Air Cleaner Mounting Bracket Kit**

This kit will mount 1 oval air cleaner to a single 4/B carburetor. Kit includes bracket, two 1/4" - 20 x 2 1/2" shoulder bolts, one 1/4" - 20 x 2" bolt, two wing nuts, and instructions.

**NOTE:** Air cleaner assembly #C3AZ-9600P4 already contains this kit. If you are ordering the assembly, you do not need to order this kit as well.

..... C3AZ-9600BRKT .....kit ..... 18.95

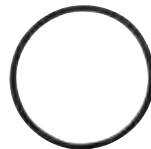

**AIR CLEANER ASSEMBLY MOUNTING GASKET**

'71 - '74 302.

..... 66248 .....ea ..... 3.95



**AIR CLEANER ADAPTER**

Allows you to use an air cleaner with a 5 1/4" diameter neck on a carburetor that has a 2 5/8" diameter neck. No more fit problems when changing carburetors. Durable high-impact, heat-resistant plastic.

..... MRG6407 .....ea ..... 8.95



**REPLACEMENT AIR FILTER FROM SPECTRE**

FROM SPECTRE

This universal fit filter can increase horsepower and fuel economy by up to 16% over other filters. Reusable - just clean and re-oil. You need never buy another filter. Round. Made of cotton fiber. Blue.

'70 - '77 With 14" air cleaner.

..... 48026 .....ea ..... 39.95



**REPLACEMENT AIR FILTERS**



A high-flow, washable filter that's been proven to be the best. Economically and ecologically sound because you don't throw it away. You buy it once, clean it and re-oil it again and again. Replaces stock element and is street legal. All K&N® filters have a 10 year, 1 million mile manufacturer's limited warranty.

'70 - '74 250 1/B ..... E1350 .....ea ..... 59.95  
'72 - '76 302 2/B ..... E1300 .....ea ..... 49.95  
'77 302 2/B ..... E1180 .....ea ..... 42.95

**AIR CLEANER KNOBS**

Fits air cleaner assembly stud size 1/4" – 20.



**With Toothed Grips**

Billet. Smooth top.

- Hole not drilled and tapped all the way through.  
 B358871A .....ea ..... 10.95
- Hole drilled and tapped all the way through.  
 B358871B .....ea ..... 10.95



**With Rubber Grips**

Triple-chrome plated finish.

- 1" diameter.  
 17585 .....ea ..... 4.95
- 1 3/4" diameter.  
 17685 .....ea ..... 6.95

**AIR CLEANER WING NUTS AND THUMBSCREW**

**Wing Nuts**



**Reproduction**

Same locking notch as OEM. Show-car quality. Fits almost everything except some 6-cylinders engines.

- '70 – '77 ..... 358871-S8 .....ea ..... 2.25



**Aftermarket – Spectre**

Will fit any 1/4" – 20 thread studs. This triple-chrome plated tri-corner design wing nut features a black wrinkle finish in the center.

- Small ..... 4210 .....ea ..... 4.95
- Large ..... 4209 .....ea ..... 6.95

**Ford Oval**

Chrome oval with dark blue center. Will fit any 1/4" – 20 thread studs.

- ..... M9697A .....ea ..... 15.95



**Thumbscrew**

- '70 – '77 6-cylinder.  
 AK241 .....ea ..... 3.75

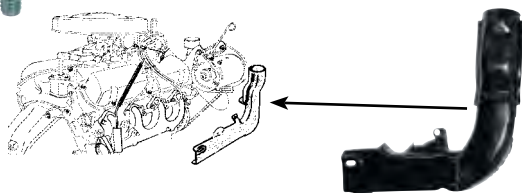

**AIR CLEANER HEAT SHROUD**

- '71 Comet 302.  
 ..... C8AZ-9A603C .....ea ..... 79.95

**STEEL VALVE COVERS**



**6-Cylinder**

Chrome. Uses twist-on oil filler cap.

- '70 – '73 170, 200, 250.  
 ..... C3DZ-6582CH .....ea ..... 39.95

**STEEL VALVE COVERS CONTINUED**



C8OZ-6A582BL



C8OZ-6A582C

**8-Cylinder**

- '71 – '72 302.  
 "Power by Ford" stamped on the covers.  
 Dark blue ..... C8OZ-6A582BL .....pr ..... 79.95  
 Chrome ..... C8OZ-6A582C .....pr ..... 100.95



**Chrome Aftermarket**

Chrome with baffles. OEM height. Hardware and gaskets not included.

- 260, 289, 302, 351W.  
 ..... 9804 .....pr ..... 49.95

**ALUMINUM VALVE COVERS**



A71122



6840G

**Polished Aluminum**

3 3/4" tall. Has a plain smooth top, 2 oil fill / PCV knock-outs in each cover and 1 screw-on baffle for each cover.

For gasket set, see part #VS13264T on next page.

For grommet kit, see part #M6892F on next page.

- 289, 302, 351W ..... A71122 .....pr ..... 99.95

Tall, polished to a high luster. Plain, smooth top and an extended lip to secure the gasket and baffle. Does not include hardware or gaskets

For gasket set, see part #5870 on next page.

- 289, 302, 351W ..... 6840G .....pr ..... 149.95



**"Cal Custom" Finned**

Polished aluminum. Does not include oil cap, oil cap grommet or PCV grommet. See part #M6892F on next page for grommet kit.

- 260, 289, 302, 351W.  
 ..... C5ZZ-6A582AF .....pr ..... 99.95



**Ford Racing**

Black with Ford Racing logo in red letters.

- 289, 302.  
 ..... M6582L302 .....pr ..... 189.95



6A582-289



6A582-302

**Small-Block "Powered by Ford"**

Black finish with brushed ribs and logo. Features an improved oil baffle design to accommodate high-lift camshafts. Works with most roller rockers.

For gaskets, see part # VS13264T below.

**NOTE:** Will not fit with EFI engines .

- "289 Powered by Ford"  
 ..... 6A582-289 .....pr ..... 179.95
- "302 Powered by Ford"  
 ..... 6A582-302 .....pr ..... 179.95
- "351 Powered by Ford"  
 ..... 6A582-351 .....pr ..... 179.95



**ALUMINUM VALVE COVERS CONTINUED**



**6A582-MV**



**6A582-CT**

**Small-Block "Powered by Ford" Continued**

"Maverick" .....	6A582-MV .....	pr .....	199.95
"Comet Powered by Ford" .....	6A582-CT .....	pr .....	179.95

\*\* For Oil Filler Caps, see pages 47-48. \*\*



**VS12692R**



**19327**

**VALVE COVER GASKETS**

**Rubber**

170, 200, 250 .....	VS12692R .....	ea .....	10.95
260, 289, 302. .....	19327 .....	pr .....	16.95

**Perma-Dry Plus**

V8 .....	VS13264T .....	pr .....	34.95
----------	----------------	----------	-------

**Rubberized Cork**

170, 200, 250. .....	19024 .....	ea .....	12.95
----------------------	-------------	----------	-------



**Ultra-Seal®**

High-density cork-and-rubber material with a steel core that prevents gasket movement at high RPMs. Non-shrinking and non-sticking. Excellent sealing and durability (can be reused). Gasket's thickness provides for additional clearance between valve train and valve cover.

260, 289, 302, 351W. .....	5870 .....	pr .....	27.95
----------------------------	------------	----------	-------



**AK1029**



**AK1039**

**VALVE COVER MOUNT KITS**

Dress up your engine with this stainless steel valve cover mounting kit. Each kit contains (12) stainless steel 3/8" hex washer head bolts and (12) 1/4" internal tooth stainless steel lock washers.

**NOTE:** Steel kits are for use with steel valve covers only, and aluminum kit are for use with aluminum valve covers only.

Fits all small-block Windsor V8s.

**With Steel Valve Covers**

Contains 1/4" x 5/8" bolts. .....	AK1029 .....	kit .....	9.95
-----------------------------------	--------------	-----------	------

**With Aluminum Valve Covers**

Contains 1/4" x 3/4" bolts. .....	AK1039 .....	kit .....	9.95
-----------------------------------	--------------	-----------	------

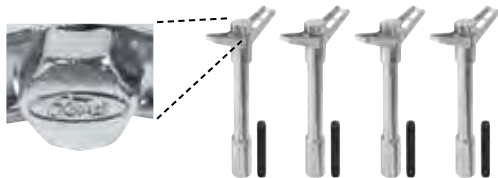

**VALVE COVER BOLTS**

For fast removal of valve covers. Chrome ends feature Ford oval logo. Amount required varies with vehicle. Set of 4.

Fits all chrome V8 valve covers. .....	M6680A302 .....	set .....	32.95
--	-----------------	-----------	-------



**PCV HOSE ELBOW**

Genuine Ford.

'71 - '73 170, 200, 250, 302. .....	C8AZ-6767B .....	ea .....	18.95
-------------------------------------	------------------	----------	-------



**EV68C**



**V158**



**EV50**



**EV76C**

**PCV VALVES**

Aftermarket.

'70 - '73 6-cylinder .....	EV68C .....	ea .....	4.50
'70 - '75 '70 - '73 Maverick 6-cylinder; '75 Maverick 6-cylinder; '71 - '75 Comet 6-cylinder. .....	V158 .....	ea .....	4.95
'71 - '72 8-cylinder .....	EV50 .....	ea .....	3.95
'73 - '77 8-cylinder .....	EV68C .....	ea .....	4.50
'74 - '75 6-cylinder .....	EV76C .....	ea .....	2.95



**C8AZ-6A892**



**E7AZ-6A892A**

**PCV GROMMETS**

Give year and engine size when ordering.

'70 - '77 6- or 8-cylinder with oil filler cap that accepts elbow. .....	C8AZ-6A892 .....	ea .....	2.95
'71 - '73 To oil filler cap. With 1" round hole. .....	E7AZ-6A892A .....	ea .....	3.95



**PCV / Oil Cap Grommet Kit**

.....	M6892F .....	kit .....	13.95
-------	--------------	-----------	-------

**FRAME MOUNTS**

'70 - '77 302.

.....	D0DZ-60289 .....	pr .....	199.95
-------	------------------	----------	--------

**NOTE:** For use with engine mount insulator #2316 (below).



**2301**



**2316**



**2341**

**ENGINE MOUNT INSULATORS**

'70 - '72 6-cylinder. LH or RH. .....	2301 .....	ea .....	19.95
'72 - '77 302. Requires 2 per vehicle. .....	2316 .....	ea .....	24.95
'73 - '77 200, 250. LH or RH. .....	2341 .....	ea .....	14.95

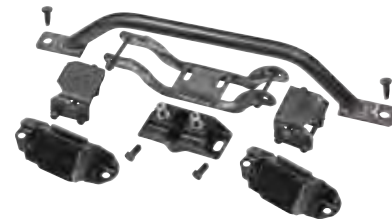

**ENGINE AND TRANSMISSION SWAP MOUNT KIT**

Upgrade your 6-cylinder to a 302 or 351W with this kit. Includes: V8 engine frame mounts, motor mounts and mounting bolts; V8 lower front crossmember and mounting bolts; V8 transmission crossmember, transmission mount, and mounting bolts.

'70 - '77 6-cylinder. .....	D1DZ-V8ENGGIT .....	kit .....	469.95
-----------------------------	---------------------	-----------	--------

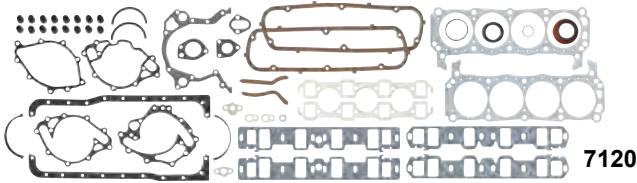

**ENGINE GASKET SETS**

A typical kit may include (but is not restricted to) such items as:

- head gaskets
- exhaust header gaskets
- timing cover gasket
- oil pan gasket
- oil pump inlet tube gasket
- timing cover seal
- water pump plate-block gaskets
- oil pan front and rear seals
- distributor mounting gasket
- crankcase vent tube gasket
- intake manifold gaskets
- intake manifold end seals
- water outlet gasket
- water pump-plate gasket
- fuel pump mounting gasket
- valve cover gasket(s)
- oil pump-block gasket
- rear main bearing seals
- oil pan drain plug gasket
- water pump cover gaskets

'70 - '77	170, 200.			
			32368CS	set..... 69.95
'70 - '77	170, 200.			
			FS7916PT2	set..... 89.95
'70 - '77	260, 289, 302.			
			FS2804	set..... 79.95
'70 - '77	221, 260, 289, 302.			
			7120	set..... 79.95

**Exhaust**

**EXHAUST TIPS**



**Replacement**

Heavy gauge, mirror-polished, 304 stainless steel with a rolled edge. Fits a 1 3/4" - 2 1/2" inlet. Features a 3" round slant and a 7" length.

'70 - '77		286202	ea	34.95
-----------	--	--------	----	-------



201S



204S

**Speed FX - Aftermarket**

Polished stainless steel with rolled edges. Universal fit. 2 1/2" inlet, 3" outlet (angle cut).

7" long.		201S	ea	26.95
12" long.		204S	ea	36.95



FX2441

**MUFFLERS - UNIVERSAL**

Features aluminized steel outer shell, baffles, end caps, and necks. Fully-welded construction for durability. Inlet is offset; outlet is centered. Produces a powerful, aggressive sound.

'70 - '77	Pipes: 2.25".			
			FX2441	ea ..... 49.95
	Pipes: 2.50".			
			FX2541	ea ..... 45.00

**Headers**

**Attention California Customers:** California vehicle code sections 27156 and 38391 prohibit the advertising, offering for sale, or installation of any device which modifies a vehicle's emission control system unless exempted. The headers in this catalog have not received an exemption from these code sections and are not legal for sale or use in California on vehicles originally equipped with catalytic converters. It is illegal—except for racing vehicles, which may never be driven upon a highway—to remove or otherwise render inoperative any emission control device on regulated motor vehicles.



**6-CYLINDER POLISHED EXHAUST HEADER KIT**

This kit by Auto Dynasty is a 6-2-1, bolt-on design. The long-tube header design allows exhaust gases to flow more freely from each of the 6 cylinders, increasing efficiency and reducing cylinder back-pressure. This improves horsepower / torque, with the added feature of positive performance-exhaust sound. Kit includes the headers, gasket, and mounting hardware.

Inlets: 1.32" x 1.6" oval. Outlet: 1.85".

**NOTE:** The kit does not include instructions. We recommend professional installation of this product.

'70 - '77	6-cylinder.			
			ADHDS-L6	kit..... 249.95

**HEDMAN® HEADERS**



Hedman Heddgers® are built using the finest materials and manufacturing procedures. Each is covered by a lifetime guarantee to the original purchaser against defects in workmanship and materials (part must be accompanied by the original sales invoice). Made in the USA.

For vehicles without A.I.R. systems, considered as OEM replacement parts when existing emission controls are not removed from vehicle.

**NOTE:** Due to size, additional shipping charges apply.

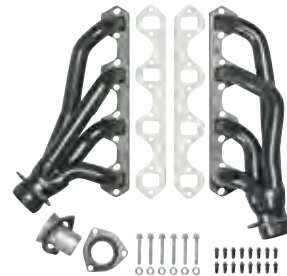

88400

**Shorty Headers**

Compact design, making them perfect for low-to-the-ground cars and tight quarters. Built using the finest materials and techniques.

1 1/2" primary tubes and 2 1/2" collectors. 16 gauge mild steel tubing.

'71 - '77 260, 289, 302 all with A/C, P/S, and floor-shift A/T, without smog injection or injection heads. Modification of stock exhaust required to retain catalytic converter.

		88400	set..... 249.95
--	--	-------	-----------------

**Polished High-Temperature Coating**

More durable than chrome, and won't peel like chrome. Gives thermal protection up to 1,300° F.

		88406	set..... 499.95
--	--	-------	-----------------

**Boxing Fee**

**Oversize**

**Truck Freight**

**HEDMAN® HEADERS CONTINUED**

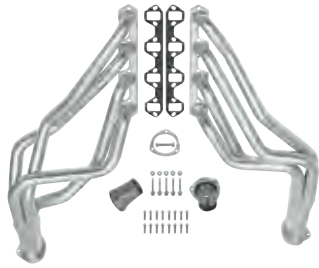

**Elite™ Headers**

Square port. 14 gauge tubing with 3/8" heavy-duty flanges. Tube size: 1 5/8". Collector size: 3" collector. Features Hedman's high-temperature coating, which offers thermal protection up to 1,300° F.

**NOTE:** Requires Power Steering Cylinder Drop-Off Bracket #88303 (see below) for installation.

'70 - '74 260 / 289 / 302 C4 A/T with floor shift, A/C and P/S but without smog injection or injection heads.  
 ⚙️ ..... 88308 ..... ea ..... 579.95

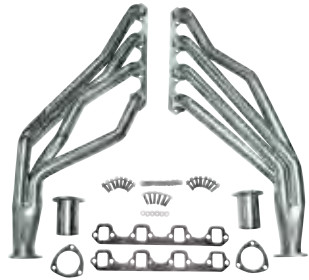

**CERAMIC COATED HEADERS**



Tube size: 1 5/8" with a 2 1/2" collector.

**NOTE:** Due to size, additional shipping charges apply.

Requires Power Steering Cylinder Drop-Off Bracket #88303 (below) for installation.

'71 - '74 302 C4 with floor shift, A/C and P/S.  
 ⚙️ ..... D668 ..... set ..... 708.90



6901



6901-1



**HOOKER® COMPETITION HEADERS**

16 gauge tubing finished with a heat-cured, high heat-resistant black paint, or optionally, with Hooker's Metallic Thermal Barrier Coating.

Tube size: 1 5/8" x 28", 3" collector.

Vehicles with P/S require Power Steering Cylinder Drop-Off Bracket #88303 (see below) for installation.

**NOTE:** Due to the size of this item, additional shipping charges apply.

'71 - '74 289 / 302 M/T or A/T with floor shift.  
**Painted**  
 ⚙️ ..... 6901 ..... pr ..... 259.95  
**Ceramic Coated**  
 ⚙️ ..... 6901-1 ..... pr ..... 436.95



**Hooker® Header Reducers**

3" inlet (from collector) with 2 1/2" outlet (to tail-pipe). 3-bolt flange. Steel reducers painted black.

⚙️ ..... HH11040 ..... pr ..... 57.95



**POWER STEERING CYLINDER DROP-OFF BRACKET**

Lowers the power steering cylinder so that it will clear some aftermarket headers.

'70 - '74  
 ⚙️ ..... 88303 ..... ea ..... 19.95



8913

**LOCKING HEADER BOLTS**

Double hex heads. 16 bolts per kit.



'70 - '77 Small-block.  
 3/8", 16 x 3/4" ..... 8913 ..... kit ..... 69.95  
 3/8", 16 x 1" ..... 8913A ..... kit ..... 74.95

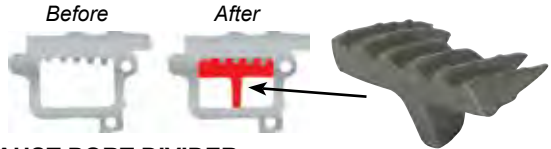

**EXHAUST PORT DIVIDER**

This cast-iron port divider is designed to correct the flow of No. 3 and 4 exhaust ports to equal that of the other cylinders. By doing so, each cylinder produces an equal amount of power at all RPM points, thus an increase of as much as 10% can be gained. This part should be bonded into place with high-temperature epoxy or tack-welded into the port.

'70 - '77 170, 200, 250.  
 ⚙️ ..... 73-1136 ..... ea ..... 24.95



**EXHAUST MANIFOLD**

'70 - '72 170, 200, 250.  
 Without IMCO ..... D3BZ-9430B ..... ea ..... 129.95



9802

133901

**MANIFOLD-TO-MUFFLER INLET PIPE GASKETS**

'70 - '77 6-cylinder.  
 ⚙️ ..... 9802 ..... ea ..... 2.95  
 '71 - '77 302.  
 ⚙️ ..... 133901 ..... ea ..... 4.95



23025



18020

**EXHAUST MANIFOLD GASKET SETS**

Made of graphite facing mechanically bonded to perforated metal most suitable for sealing hot exhaust gases.

'70 - '77 170, 200, 250.  
 ⚙️ ..... 23025 ..... ea ..... 14.95  
 260, 289, 302.  
 ⚙️ ..... 18020 ..... pr ..... 19.95



**EXHAUST MANIFOLD / HEADER GASKET SET**

Can be used for exhaust manifold or header gaskets. Port size: 1.12" x 1.48". Set of 2.

'71 - '77 302.  
 ⚙️ ..... 5930 ..... pr ..... 24.95

## Wiring / Electrical

**NOTE:** Electrical parts are non-returnable once installed. We will replace defective units only.

**NOTE:** We have available a limited number of NOS switches not listed in our catalogs. Please call if you do not find listed the switch you need.



### FLAME-THROWER® STOCK-LOOK CAST-ALUMINUM DISTRIBUTOR **PERTRONIX**

Features a lightweight cast-aluminum housing modeled after the original Motorcraft® distributors. Built with all-new components, not remanufactured parts like the other guys. No longer will you need to hassle with adjusting points or replacing capacitors, because this distributor is equipped with maintenance-free Ignitor® electronics, providing decades of trouble-free operation.

This distributor is complete with the original Ignitor® and high dielectric strength cap and rotor with brass contacts, so you're ready to run right out of the box. Also features a hardened gear, ground to exact tolerances for precise meshing with the cam; adjustable vacuum-advance canister that provides extra tunability; optimized phasing that ensures maximum energy to the spark plug; and tailored advance curve for optimal performance and drivability.

'70 - '74 221 / 260 / 289 / 302 without electronic ignition.  
 ⚙️ ..... D134600 .....ea ..... 212.10



### FLAME-THROWER® BILLET DISTRIBUTOR **PERTRONIX**

Upgrade your outdated points or stock electronic distributor to a performance-proven distributor featuring the patented Ignitor® II electronic ignition module and a CNC machined 6061 T-6 polished billet housing and deck. PerTronix® electronics are compatible with any inductive ignition system coil, but high RPM performance can be improved when used with a low resistance (0.6 ohm) Flame-Thrower® II coil (see next page).

Compatible with multi-spark CD ignition boxes. Features a tempered .500" diameter shaft with low torsion displacement; an upper roller bearing; lower self-lubricating, oil-impregnated copper powder metal bushing; and a durable machined heat-treated gear. Distributors come with a factory set performance curve, a mechanical advance-limiting adjustment. Black cap.

'70 - '73 289 / 302 without factory electronic ignition.  
 ⚙️ ..... D130700 .....ea ..... 277.57

#### Replacement Cap for the Above

Black.  
 ⚙️ ..... D650700 .....ea ..... 29.95

#### Replacement Rotor for the Above

Black.  
 ⚙️ ..... D660701 .....ea ..... 13.31



### FLAME-THROWER® HEI DISTRIBUTORS **PERTRONIX**

Performs misfire-free up to 7,500 RPM, nearly 3,000 RPM higher than the original factory HEI. Finally, a coil and module engineered to work together. Limited 1-year manufacturer's warranty.

260, 289, 302.  
 Black cap.  
 ⚙️ ..... D1350 .....ea ..... 280.76  
 Blue cap.  
 ⚙️ ..... D1352 .....ea ..... 280.76

**D1352**

## FLAME-THROWER® HEI DISTRIBUTORS CONTINUED



### Replacement Caps for HEI Distributors

Black.  
 ⚙️ ..... D4050 .....ea ..... 29.95  
 Blue.  
 ⚙️ ..... D4052 .....ea ..... 29.95

**D4050**

## IGNITOR® ELECTRONIC IGNITION SYSTEMS **PERTRONIX**



**1281**

### Ignitor® I

Improvement over points in current fall time for increased coil output. Features rotating cobalt magnets which trigger a Hall Effect integrated circuit. Will trigger most multi-spark CD ignitions. Available for 6- and 12-volt negative and positive ground systems.

For optimal performance, use with Flame-Thrower® 40,000-volt coil (see next page).

'70 - '74 V8 with single-point distributor.  
 Use with coils #40001 (chrome) or #40011 (black).  
 ⚙️ ..... 1281 .....ea ..... 89.95  
 '70 - '72 V8 with dual-point distributor.  
 Use with coils #40001 (chrome) or #40011 (black).  
 Without vacuum advance.  
 ⚙️ ..... 1281D .....ea ..... 95.96  
 '70 - '72 V8 with dual-point distributor.  
 Use with coils #40001 (chrome) or #40011 (black).  
 With vacuum advance.  
 ⚙️ ..... 1281DV .....ea ..... 91.06  
 '70 - '74 6-cylinder with Motorcraft® single-point distributor.  
 Use with coils #40501 (chrome) and #40511 (black).  
 ⚙️ ..... 1261 .....ea ..... 89.95



### Ignitor® II

Has many of the same great features of the Ignitor® I, but it's smarter. The Ignitor® II senses the coil current levels and uses a powerful microcontroller to control dwell period for the best possible spark over the entire RPM range, thus reducing misfires and improving engine performance. Ignitor® II systems develop up to 4 times more energy between 3,000 and 5,000 RPMs than standard ignition systems. Peak current level is reached just prior to spark for maximum energy without the heat buildup, increasing coil and module life. Adjusts spark timing at higher RPMs to compensate for the inherent electronic delay. Senses startup and develops more energy for quicker, easier starting. Built-in reverse polarity and over-current protection shuts down the system, preventing component damage.

Use with Flame-Thrower® II 45,000-volt coil for optimal performance.

'70 - '72 V8 with dual-point distributor.  
 Use with coils #45001 (chrome) or #45011 (black).  
 Without vacuum advance.  
 ⚙️ ..... 91281D .....ea ..... 136.33  
 With vacuum advance.  
 ⚙️ ..... 91281DV .....ea ..... 129.39  
 '70 - '74 V8 with Motorcraft® single-point distributor.  
 Use with coils #45001 (chrome) or #45011 (black).  
 ⚙️ ..... 91281 .....ea ..... 124.17



### Ignitor® III

Millions have upgraded their point-type ignitions with original Ignitor® and Ignitor® II electronic modules. Ignitor® III upgrades even more by adding thermal-clad construction, integrated adjustable rev limiter with LED feedback and multi-spark ignition.

Use with Flame-Thrower® II coils (part #44001 and or part #44401) for optimal performance.

'70 - '74 8-cylinder with single-point Motorcraft® distributor.  
 ⚙️ ..... 71281 .....ea ..... 149.95



**IGNITOR®  
POWER  
RELAY KIT**



Most vehicles are equipped with OE resistant wires or ballast resistors. When using the Ignitor® II and Ignitor® III ignition systems, they require a full +12V power

connection between the ignition switch and the positive coil terminal. To get the full benefit of the PerTronix® high-performance ignition system, the primary resistance needs to be eliminated or bypassed. In most cases, it is easier to add the PerTronix® ignition power relay rather than cutting into the vehicle's wiring harness and replacing wires.

Kit includes: 30-amp auto relay, relay socket and harness, 3-amp 400-volt diode, mounting screw, and connectors. Comes with easy-to-follow instructions that include an 800-number tech line for additional help.

'70 - '77 ..... PR30A.....kit..... 39.95



**DIGITAL HP  
IGNITION BOXES**



The Digital HP ignition box represents the latest innovation in ignition technology. Its ultra-small form factor (4.18" long, 5.75" wide and 1.65" high) provides more installation options, and the

simple dial interface accommodates quick and easy adjustments.

This ignition box features:

- 187 milli-Joules of spark energy
- multiple spark all the way to redline
- on-board diagnostics and tach calibration
- integrated 3-step digital rev limiter (burnout limit, launch control and fatal over rev protection)
- RPM-activated trigger (accurately controls shift lights, solenoids and other RPM devices)
- adjustable start retard and locking Molex connector.

50 state emissions legal – C.A.R.B. E.O. #D-57-37.

**Specifications:**

Operating voltage: 9–22 volts, cranking voltage: 8–22 volts  
Current draw: 1.2A per 1,000 RPM  
Input triggers: Points, Electronic, or Mag  
Output voltage: 530 volts, output energy: Up to 187 mJ primary  
Multi-spark window: Up to 20 crank degrees  
Start retard: 0–18 degrees / 500–1,400 RPM.

Mounting bolt pattern is 3.5" x 3.25".

Use with coils part #s 60100, 44001, or 44011 (next column).

90-day manufacturer's warranty.

Black anodized ..... 510 .....ea ..... 217.21  
Silver anodized ..... 512 .....ea ..... 217.21



**FLAME THROWER®  
SPARK PLUG WIRE SETS**



Low resistance, high performance, stock look. These wires have a low 500 ohms-per-foot resistance. Silicone jackets are used to resist high temperatures, moisture, oil and chemicals. Manufacturer's lifetime warranty. Made in the USA.

**7.0 mm**

'70 - '77 Maverick 6-cylinder; '71 - '76 Comet 6-cylinder.  
⚡ ..... SPW4 .....set..... 49.95  
'71 - '74 302.  
⚡ ..... SPW1 .....set..... 59.95  
'75 - '76 302.  
⚡ ..... SPW2 .....set..... 49.95

**8.0 mm HEI**

For use with HEI distributors #s D1350 and D1352.

260, 289, 302 ..... SPW3 .....set..... 59.95



40501 40001 40011 45001 45011

**FLAME-THROWER IGNITION COILS**



High performance ignition coil replaces most canister type coils in distributor-type induction ignition systems. Maximizes energy and reliability over the full RPM range, enables larger plug gaps for greater fuel efficiency and more power, delivers an average of 15% more spark energy and voltage and fits existing brackets. Legal in all 50 states. 90-day manufacturer's warranty.

**Flame-Thrower®**

40,000 volts.

'73 - '74 6-cylinder.  
3.0 ohms resistance.  
Chrome.

⚡ ..... 40501 .....ea ..... 49.95

⚡ ..... 40511 .....ea ..... 39.95

'73 - '77 6- or 8-cylinder.  
1.5 ohms resistance. Oil filled.  
Chrome.

⚡ ..... 40001 .....ea ..... 40.51

⚡ ..... 40011 .....ea ..... 39.95

**Flame-Thrower® II**

45,000 volts.

'73 - '77 6- or 8-cylinder.  
0.6 ohms resistance.  
Chrome.

⚡ ..... 45001 .....ea ..... 49.95

⚡ ..... 45011 .....ea ..... 44.95

**Flame Thrower® III 6- or 8-Cylinder**

45,000 volts, 0.32 ohms resistance.

For use with Ignitor® III ignition system (part #71281 in previous column).

Chrome ..... 44001 .....ea ..... 49.95

Black ..... 44011 .....ea ..... 49.95



**Flame Thrower® HP**

This HP (high power) 50,000 volt E-core coil is specifically designed for use with the PerTronix® Digital HP ignition.

It features:

- highly efficient epoxy-filled E-core design
- vacuum-potted body for longer life and increased reliability
- 6063 T5 aluminum heat sink with anodized corrosion-resistant finish
- precision-machined male high-tension terminal
- brass primary terminals

Maximum voltage 50,000, Primary resistance 0.2 ohms.

Suitable for 4-, 6- and 8-cylinder engines when using the PerTronix® Digital HP ignition box. Legal in all 50 states and Canada (C.A.R.B. E.O. #D-57-21).

For HP ignition box, see part #510 or #512 (previous column)

For use with Ignitor® III ignition system (part #71281 on previous page).

**NEW** Black ..... 60100 .....ea ..... 87.23

C.A.R.B. = California Air Resources Board



**B6A-12019**



**DG313A**



**DG314**

**IGNITION COILS**

- '70 - '77 Yellow top coil.
  - ☛ ..... B6A-12019 .....ea ..... 39.95
- '70 - '77 Blue with black top. Replacement; not like original.
  - ☛ ..... DG313A .....ea ..... 24.95
- '75 - '77 Maverick except '77 California; Comet 6- or 8-cylinder with breakerless ignition, except '77 California. Black.
  - ☛ ..... DG314 .....ea ..... 19.95

**C4DZ-12043A**



**C4DZ-12043S**



**IGNITION COIL BRACKETS**

- '70 - '77 V8. Black.
  - ☛ ..... C4DZ-12043A .....ea ..... 14.95
- Stainless steel.
  - ☛ ..... C4DZ-12043S .....ea ..... 21.95



**POINTS ELIMINATOR KIT**

BY ACCEL®

Puts an end to replacing points while improving performance and fuel efficiency. This system uses special electronic circuitry and an infrared signal that allows ignition timing to be stable from 1 to 10,000 RPM. The Thermal Clad-based surface mount allows for maximum dependability and long life. Can be installed with simple hand tools.

- '70 - '74 V8 with Motorcraft® single-point distributor.
  - ☛ ..... 2020 .....kit ..... 99.95



**DISTRIBUTOR HOLD-DOWN CLAMP**

Chrome. Includes installation bolt.

- V6, V8 except FE.
  - ..... M12270A302 .....ea ..... 10.95



**DISTRIBUTOR CAP AND ROTOR KIT**

Features both a blue distributor cap and a blue rotor. The cap has brass contacts.

- V8 ..... G5208 ..... kit ..... 24.95



**DISTRIBUTOR CAP**

Black with brass contacts, no logo.

- '70 - '77 8-cylinder; '71 - '73 Comet.
  - ☛ ..... B7A-12106A .....ea ..... 12.95

**SPARK PLUG WIRES - 7MM**



**Motorcraft**

All plug wires black have straight orange boots on plug end and straight black boots on cap end. Includes coil wire.

- '70 - '76 6-cylinder.
  - ☛ ..... E5PZ-12259MR .....set ..... 23.95
- '71 - '73 302.
  - ☛ ..... E5PZ-12259HR .....set ..... 47.95

**SPARK PLUG WIRES - 7MM CONTINUED**



**D3DZ-12259A**



Ends

**OE Replacements**

High-temperature wires with conductive silicone core and silicone jacket. Black wires and boots. Includes coil wire. All the plug wires are straight at the plug end and cap end.

- '70 - '76 6-cylinder.
  - ☛ ..... D1AZ-12259B .....set ..... 20.95
- '71 - '73 302.
  - ☛ ..... D3DZ-12259A .....set ..... 29.95



**SPARK PLUG WIRES - 8MM**



High-performance 8mm spark plug wires for 6-cylinder engines. These custom-fit wires require no trimming and are made with a premium nickel-chromium spiral-wound inner core, silicone boots / outer jacket, brass distributor terminals, and stainless steel spark plug terminals. Printed with a repeating Ford logo, they also come pre-marked with the correct cylinder numbers for easy installation.



**C4DZ-12259BL**

- 170, 200, 250.
  - Black ..... C4DZ-12259BK .....set ..... 44.95
  - Blue ..... C4DZ-12259BL .....set ..... 44.95



**B8Q-12297A**



**B6A-12297A**



**D7AZ-12297B**

**SPARK PLUG WIRE SEPARATORS**

- '70 - '73 8-cylinder. Has 7-8 mm openings.
  - ☛ ..... B8Q-12297A .....ea ..... 2.95
- '73 - '76 6-cylinder requires 1; 8-cylinder requires 2.
  - ☛ ..... B6A-12297A .....ea ..... 1.50
- '75 - '77 8-cylinder. Requires 2. Has 9 mm openings.
  - ☛ ..... D7AZ-12297B .....ea ..... 2.95



**12297SETRD**

**Spark Plug Wire Separators Sets**

Made from ABS plastic. Includes 2 valve cover-mounted separators and 2 regular separators.

- Black ..... 12297SETBK .....set ..... 9.95
- Blue ..... 12297SETBL .....set ..... 14.95
- Red ..... 12297SETRD .....set ..... 13.95



**45**



**24**

**SPARK PLUGS**

- '70 - '74 '70 with 18 mm thread; '71 - '74 302. Autolite.
  - ☛ ..... 45 .....ea ..... 2.50
- '70 - '77 '70 Maverick 250; '71 - '72 Maverick / Comet 170, 200, 250; '73 - '77 Maverick / Comet 200, 250. Autolite.
  - ☛ ..... 46 .....ea ..... 2.25
- '71 302 4/B. Autolite.
  - ☛ ..... 24 .....ea ..... 2.00



**SPARK PLUGS CONTINUED**

'71 - '73 302.  
Motorcraft.  
BSF42C .....ea ..... 3.95

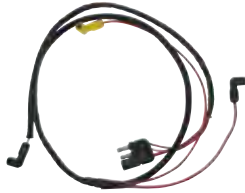

**FIREWALL-TO-ENGINE GAUGE FEED**

'71 302.  
D1AZ-14289B .....ea ..... 26.95



**OIL PRESSURE SENDING UNIT**

'70 - '77  
SW1311 .....ea ..... 13.95



**SW663**



**SW626**

**WATER TEMPERATURE SENDING UNITS**

'70 - '77 '70 - '76 Maverick all; '77 Maverick 200, 250, 302 without VV carburetor; '71 - '77 Comet without VV carburetor.  
SW663 .....ea ..... 13.95  
'77 302 2/B..... SW626 .....ea ..... 29.95



**HORN RELAY**

'70 - '77 Maverick; '71 - '72 Comet.  
C7AZ-13853 .....ea ..... 19.95

**HORNS**



**Replacements**

Fits most 1960-79 Ford and Mercury vehicles.  
Excellent reproduction set of replacement horn assemblies for left and right sides. Includes mounting brackets and nuts.  
High and low tone.  
13832/3SET .....set..... 109.95



**BH101LC**



**BH101HC**

**Aftermarket**

OE replacement-style. Universal fit and easy to install. 125 dB sound level. Corrosion-resistant. Includes hardware. For 12 volt systems.  
Low tone..... BH101LC .....ea ..... 14.95  
High tone..... BH101HC.....ea ..... 14.95

**NEUTRAL SAFETY SWITCHES AND BOLTS**



**Switches**

'70 with non-locking column shift, without vacuum brake release.  
NOS. Limited quantity.  
SW868A .....ea ..... 249.95

**NEUTRAL SAFETY SWITCHES AND BOLTS CONTINUED**



**D1FZ-7A247A**



**SW1615**



**SW1148**



**SW1225**

**Switches Continued**

'71 - '72 C4 A/T before 12/1/71.  
Reproduction.  
D1FZ-7A247A .....ea ..... 49.95  
'71 - '72 '71 Maverick C4; '71 - '72 Comet A/T before 12/71.  
Aftermarket.  
SW1615 .....ea ..... 69.95  
'72 - '73 C4 with console shift after 12/1/71.  
NOS.  
SW1148 .....ea ..... 149.95  
'74 - '77 C4 with console shift.  
NOS.  
SW1225 .....ea ..... 69.95



**Mounting Bolts**

Set of 2 bolts with star washers.  
Ford / Mercury with C4 or C6 A/T and transmission-mounted neutral safety switch.  
42746-S .....pr ..... 3.95



**A/C COMPRESSOR SWITCH AND BRACKET**

Compressor brush and bracket.  
'72 Maverick with hang-on A/C.  
C8SZ-2979A .....ea ..... 36.95



**ENGINE / TRUNK LAMP KIT**

This dome-shaped cover with bulb included comes with wire and is an exact copy of the original Ford kit. For engine compartment and / or trunk.

'70 - '72 C2RZ-15A700A.....kit ..... 29.95



**UNIVERSAL 21-CIRCUIT WIRING HARNESS KIT**

This universal wiring harness kit from Painless is easy to install and features color-coded high-temperature TXL wire with each circuit's routing clearly printed the full length of each wire. Includes all the connectors, fuses, flashers, relays and wire ties you will need for installation. Comes with easy-to-read and -follow instructions. Uses blade-type fuses.

'70 - '76 10123 .....kit ..... 629.95



**SOLDERLESS WIRE TERMINAL / CONNECTOR KIT**

Contains an assortment of the 18 most popular solderless, insulated terminals and connectors. Comes in a plastic display box with dividers. Includes 9" crimping tool. 175 pieces.  
TK50413A .....kit ..... 19.95

Transmission

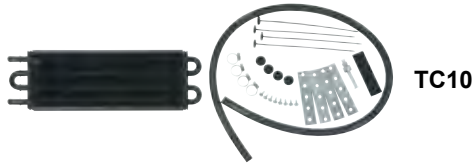

TRANSMISSION COOLERS – HEAVY DUTY

**Light Service**

Rated up to 14,000 lbs. GVW, 2,500 lbs. towing. Copper and aluminum core with black power coat finish. Overall size: 5" x 17" x 3/4".

TC10 .....ea ..... 39.95

**Medium Service**

Rated up to 16,000 lbs. GVW. Aluminum tubes and fins. Overall size: 7 1/2" x 15 1/8" x 3/4", with 3/8" nipple inlet and outlet.

TC16 .....ea ..... 44.95

**Heavy Service**

Rated up to 18,500 lbs. GVW. Copper tubes with aluminum fins. Overall size: 7 1/2" x 17" x 3/4". Inlet size: 1 1/2" barb. Hose size: 1 1/2" x 4'.

TC18 .....ea ..... 59.95



**AUTOMATIC TRANSMISSION FILTER / GASKET KIT**

Kit contains 1 gasket and 1 filter.

'70 - '77 C4.

K7 .....kit ..... 8.95

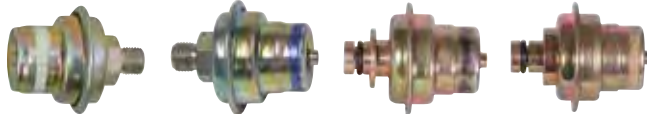

TM9

C1AZ-7A377B

FM2315

FM2317

TRANSMISSION MODULATORS (SHIFT DIAPHRAGMS)

'70 - '74 C4.  
1/2" - 20 thread, single hose, White stripe.  
TM9 .....ea ..... 19.95

'70 - '75 FMX.  
1/2" - 20 thread, single hose, Blue stripe.  
C1AZ-7A377B .....ea ..... 19.95

'70 - '77 302 2/B.  
Black stripe.  
FM2315 .....ea ..... 22.95

'72 - '77 '72 C4; '73 302 2/B C4; '73 - '77 6-cylinder C4; '74 - '77 8-cylinder C4.  
Yellow stripe.

FM2317 .....ea ..... 14.95



C5DZ-7986A



C5DZ-7986B



C5AZ-7986A

A/T TRANSMISSION INSPECTION PLATES

'70 - '77 Maverick 170, 200 C4; '71 - '72 Comet 200 C4.  
C5DZ-7986A .....ea ..... 19.95

'70 - '77 '70 - '75 Maverick 302 C4; '70 - '77 Maverick 250 C4; '71 - '72 Comet 250 / 302 C4.  
C5DZ-7986B .....ea ..... 16.95

'71 - '72 Comet 302 with FMX transmission.  
C5AZ-7986A .....ea ..... 24.95

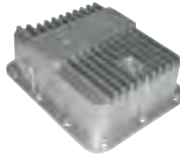

DEEP TRANSMISSION OIL PANS – ALUMINUM



Holds more fluid for more efficient cooling. Their aluminum construction makes them stronger than stock steel pans and promotes faster heat dissipation for further cooling of your transmission.

Includes pan, gasket, drain plug and attaching hardware. 7" wide x 9" long x 4" deep with PA logo.

PA26403

C4 case fill.  
PA26403 .....ea ..... 130.00

C4 pan fill.  
PA26404 .....ea ..... 154.00



PA26406



TRANSMISSION DIPSTICK AND FILLER TUBES

Has a "no leak" hat seal and lock-top stick to prevent any fluid from coming out your dipstick tube when pressure builds.

C4 case fill.  
PA26406 .....ea ..... 89.95

C4 pan fill.  
PA26407 .....ea ..... 84.95

TRANSMISSION DIPSTICKS

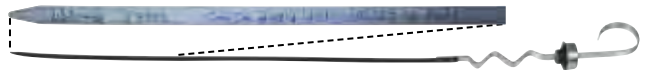

Reproduction

'70 C4 .....C6OZ-7A020B .....ea ..... 19.95



Aftermarket

Mounts on the transmission. High-tech dipstick featuring a braided stainless steel hose. Instructions included.

'70 - '77 C4.  
TD30C4TM .....ea ..... 119.95

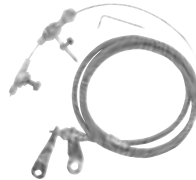

TRANSMISSION KICK-DOWN CABLE KIT



'70 - '77 C4.  
KD20C4HT .....kit ..... 109.95

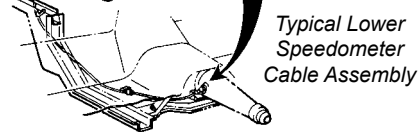
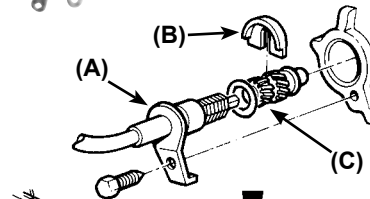

Typical Lower Speedometer Cable Assembly



B9TZ-17264R



C1DZ-17292A

SPEEDOMETER CABLE CLIP (A)

Attaches the speedometer cable to the transmission housing.

'70 - '77 B9TZ-17264R .....ea ..... 5.95

SPEEDOMETER DRIVEN GEAR RETAINER CLIP (B)

C-type clip.

'70 - '77 C1DZ-17292A .....ea ..... 3.95





**C5ZZ-17285A**



**C2DZ-17271-16**



**C0DZ-17271B**

**SPEEDOMETER GEARS (C)**

SEE DIAGRAM ON PREVIOUS PAGE

**Drive Gears**

LH tilt. 1 3/8" I.D., 1 13/16" O.D., 1 1/16" thick.

6 teeth	Pink.		
		C5ZZ-17285A	ea ..... 19.95
7 teeth	Black.		
		C4DZ-17285A	ea ..... 19.95

**Driven Gears**

**LH Tilt**

White (color may not be correct).

16 teeth		C2DZ-17271-16	ea ..... 9.95
17 teeth		C2DZ-17271-17	ea ..... 9.95
18 teeth		C2DZ-17271-18	ea ..... 9.95
19 teeth		C2DZ-17271-19	ea ..... 9.95
20 teeth		C2DZ-17271-20	ea ..... 9.95
21 teeth		C2DZ-17271-21	ea ..... 9.95

**RH Tilt**

16 teeth	Burgundy.		
		C0DZ-17271A	ea ..... 9.95
17 teeth	White.		
		C3DZ-17271C	ea ..... 9.95
18 teeth	Yellow.		
		C0DD-17271B	ea ..... 9.95
19 teeth	White.		
		C0DZ-17271B	ea ..... 9.95
20 teeth	Black.		
		C1DZ-17271A	ea ..... 9.95

**TRANSMISSION MOUNTS**



**Rubber**

Distance between transmission-side mounting holes, center-to-center: 5 1/2". Distance between crossmember-side mounting studs, center-to-center: 2 3/4".

'70 - '77		2333	ea ..... 18.95
-----------	--	------	----------------



**6-1605BL**



**41136G**

**Polyurethane**

Replacements. Black polyurethane. Built to control torque and eliminate breakage.

'70 - '77		6-1605BL	ea ..... 49.95
'71 - '77	8-cylinder.		
	Includes the mount, backing plate, mounting hardware and installation instructions.		
		41136G	set ..... 49.95



**SHIFT IMPROVER KIT**



The easy way to get faster shifts, longer clutch and band life, better fuel economy, and cooler running temperatures. Choose between two performance types: heavy duty or street / strip. Takes just a few hand tools and a few hours to improve your transmission into the solidly-tuned unit you want. Kit includes a pan gasket, specialty separator plates, twist drill and step-by-step instructions.

'70 - '77	C4	50262	kit ..... 49.95
-----------	----	-------	-----------------



**SHIFT LINKAGE REPAIR KIT**

Includes 3 each of studs, nuts, washers, and pins.

'71 - '76	'71 - '73 Maverick with 3-speed; '73 - '76 Maverick, all with M/T floor shift; '71 - '72 Comet, all with M/T.		
		C5ZZ-7285RPK	kit ..... 22.95



**TRANSMISSION CROSSMEMBER**

'70 - '77	8-cylinder with C4, 3- or 4-speed toloader. Works with dual exhaust.		
		D0DZ-6A023	ea ..... 99.95



**SMALL-BLOCK C6 AUTOMATIC TRANSMISSION**



The economical TCI Street Rodder C6 transmission is ideal for small-block powered vehicles, producing up to 400 horsepower - perfect for a mild daily driver, muscle car, or street rod. Equipped with a TCI automatic valve body and valve body improver kit, it gives a firmer, yet not-too-harsh shift while remaining fully automatic. Features a forward shift pattern, stock pan, 13.500" tail shaft, 32-spline input shaft, and case fill. Torque converter and dipstick / tube are not included.

**NOTE:** Shipped without the speedometer driven gear or its housing. If replacing the same model of transmission, these may be re-used from existing. If not, they must be purchased separately. This transmission is not SFI-approved. Free shipping in lower 48 states.

289, 302, 351W	TCI-SBC6	ea ... 1,472.00
----------------	----------	-----------------



**FRG157N**



**C3AZ-6375J**

**FLYWHEEL RING GEAR**

'70 - '77	'70 - '77 250 M/T; '71 - '72 302 M/T. 157 teeth, 12" I.D. Replacement.		
		FRG157N	ea ..... 29.95

**FLYWHEELS - MANUAL TRANSMISSION**

'71 - '77	Maverick 302; '71 - '72 Comet 302 2/B.		
		C3AZ-6375J	ea ..... 179.95



**FLYWHEEL BOLTS AND WASHERS**

Includes 6 bolts and 6 washers. 7/16" - 20 x 1". Grade 8. 912



**C3DZ-6375B**



**E0AZ-6375A**

**FLEXPLATES - AUTOMATIC TRANSMISSION**

'70 - '77	'70 - '72 Maverick 170, 200; '73 - '77 Maverick / Comet 200 C4.		
	Does not include ring gear.		
		C3DZ-6375B	ea ..... 22.95
'76 - '77	'76 Comet 302 with pan fill transmission; '77 Maverick / Comet 302 FMX and C4 Overdrive.		
	164 teeth, 12° pitch, 14.23" O.D. 28.2 oz. balance weight.		
		E0AZ-6375A	ea ..... 29.95



**FLEXPLATE BOLTS AND WASHERS**

Includes 6 bolts and 6 washers.  $\frac{7}{16}$ " - 20 x  $1\frac{3}{16}$ ".

..... 6711 ..... set..... 19.95



**High Performance**

$\frac{7}{16}$ " - 20 x .680". Superior to OEM fasteners and rated at 180,000 PSI, these bolts are forged from aerospace alloy steel before machining. Features include black oxide finish, 12-point head design and a larger-than-OEM shank diameter. Does not include washers. Set of 6.

289 - 400.

..... 100-2901 ..... set..... 16.95



**BELLHOUSING SEPARATOR PLATE**

9 bolt holes and 2 pin holes. Includes inspection plate.

**NOTE:** This will not fit smaller bellhousings with 157-tooth flexplates.

'71 - '73 302 C4 with 164-tooth flexplate.

..... C9DZ-7007/7986 ..... ea ..... 49.95



**C3AZ-4841D**

**DRIVE SHAFT YOKES**

For small-block V8. No specific applications are available. Please check measurements before ordering.

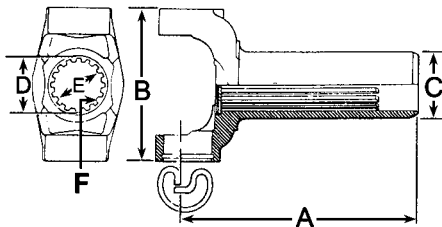

- (A) Length from center or u-joint hole to end of shaft:  $8\frac{3}{32}$ "
  - (B) Outside-to-outside length of u-joint:  $3\frac{1}{2}$ "
  - (C) O.D. of shaft:  $1\frac{1}{2}$ "
  - (D) I.D. of shaft to spline:  $1\frac{19}{32}$ "
  - (E) I.D. of spline:  $1\frac{13}{32}$ ".
  - (F) 28 splines. Uses an outer lock ring.
- ..... C3AZ-4841D ..... ea ..... 89.95

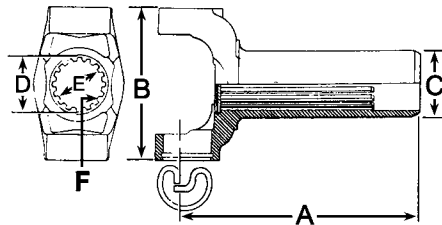

- (A) Length from center or u-joint hole to end of shaft:  $7\frac{3}{4}$ "
  - (B) Outside-to-outside length of u-joint:  $3\frac{1}{2}$ "
  - (C) O.D. of shaft:  $1\frac{1}{2}$ "
  - (D) I.D. of shaft to spline:  $1\frac{17}{16}$ "
  - (E) I.D. of spline:  $\frac{63}{64}$ ".
  - (F) 25 splines. Uses an outer lock ring.
- ..... C3DZ-4841A ..... ea ..... 99.95

**DRIVE SHAFT YOKES CONTINUED**

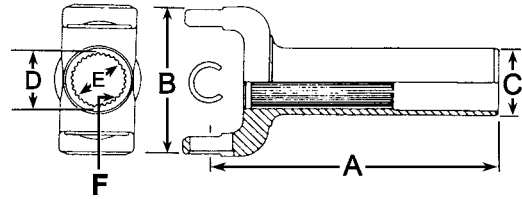

- (A) Length from center or u-joint hole to end of shaft:  $8\frac{3}{32}$ "
  - (B) Outside-to-outside length of u-joint:  $3\frac{1}{2}$ "
  - (C) O.D. of shaft:  $1\frac{1}{2}$ "
  - (D) I.D. of shaft to spline:  $1\frac{19}{32}$ "
  - (E) I.D. of spline:  $1\frac{13}{32}$ ".
  - (F) 28 splines. Uses an inner c-clip.
- ..... C5DZ-4841A ..... ea ..... 99.95



**U-JOINT REPAIR KIT - UNIVERSAL**

For driveshaft u-joints with  $1\frac{1}{8}$ " O.D. bearings. Kit includes (1)  $1\frac{1}{4}$ " U-bolt; (2)  $\frac{5}{16}$ " - 18 hex nuts; (2)  $\frac{5}{16}$ " lock washers.

With driveshaft u-joints that have  $1\frac{1}{8}$ " O.D. bearings.  
 ..... 81004 ..... kit ..... 4.95

**Clutch**

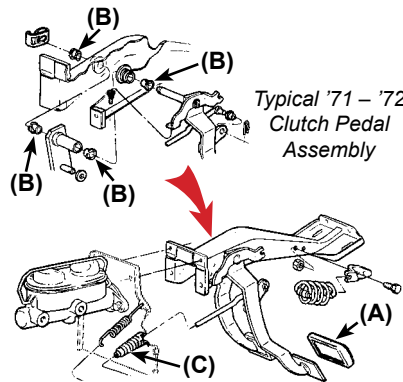

**C5ZZ-7A624B**



**C5ZZ-7B544A**

**CLUTCH PEDAL PAD AND TRIM (A)**

'70 - '77 Pad ..... C5ZZ-7A624B ..... ea ..... 3.95  
 Trim ..... C5ZZ-7B544A ..... ea ..... 6.95



**CLUTCH PEDAL ARM MOUNTING BRACKET BUSHING (B)**

Requires 2 per arm.

'70 - '77

..... B7AZ-2471B ..... ea ..... 1.95



**1508BUSH**



**C5ZZ-2478RB**

**CLUTCH PEDAL SUPPORT REPAIR KITS**

**Bushing Kits**

Kit includes 2 plastic bushings, 2 snap rings and 2 metal sleeves.

'70 - '77 M/T.  
 Without roller bearings and metal sleeves.  
 ..... 1508BUSH ..... kit ..... 22.95  
 With roller bearings and metal sleeves.  
 ..... C5ZZ-2478RB ..... kit ..... 39.95

**CLUTCH PEDAL SUPPORT REPAIR KITS CONTINUED**

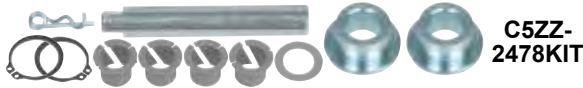

**Support Rebuild Kit**

Replacement style. Kits include 2 metal sleeves, 1 retainer pin, 2 snap rings, and 1 pedal support shaft (5/8" diameter x 4 1/4" long).

- '70 - '73 M/T.  
Without roller bearings.  
Also includes 4 plastic bushings and 1 flat washer.  
⌘ ..... C5ZZ-2478KIT .....kit..... 39.95
- With roller bearings.  
Also includes 2 plastic bushings, 2 wave (crush) washers, and 2 flat washers.  
⌘ ..... C5ZZ-2478RBMK .....kit..... 61.95



**CLUTCH PEDAL ROD-TO-FIREWALL SEAL (C)**

SEE DIAGRAM ON PREVIOUS PAGE  
'70 - '77 Maverick 6- or 8-cylinder; '71 - '72 Comet 6- or 8-cylinder; '73 - '77 Comet 8-cylinder.  
⌘ ..... C6OZ-7A533C .....ea ..... 10.95

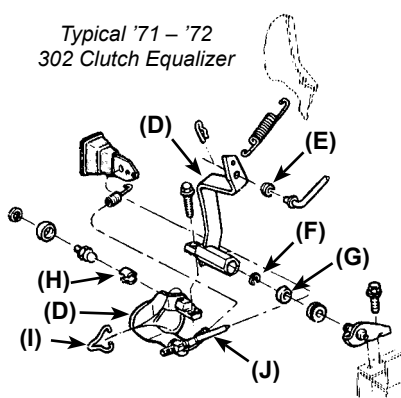

**CLUTCH EQUALIZER PARTS**

**Clutch Release Equalizer Bar (D)**

2 piece as original.  
'70 - '77 302.  
⌘ ..... D1DZ-7528AB .....ea ..... 209.95

**Idle Lever Bushing (E)**

3/8" I.D.  
'70 - '77 ⌘ ..... C0AZ-7526B .....ea ..... 2.95

**Shaft Bearing Retainer (F)**

'70 - '77 C-type.  
⌘ ..... C1DD-7A629A .....ea ..... 4.50

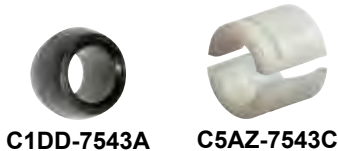

**Ball - At Clutch Release Equalizer Bar (G)**

'70 - '77 6-cylinder.  
⌘ ..... C1DD-7543A .....ea ..... 2.95

**Equalizer Bar Split Bushing (Socket) (H)**

2-piece bushing to replace the original 1-piece socket.  
'71 - '77 6- or 8-cylinder.  
⌘ ..... C5AZ-7543C .....ea ..... 24.95



C5AZ-7B545A



C5AZ-7543CKIT

**CLUTCH EQUALIZER PARTS CONTINUED**

**Equalizer Bar Bushing Retainer Clip (I)**

Hold the C5AZ-7543C bushing in the equalizer bar.  
'71 - '77 8-cylinder.  
⌘ ..... C5AZ-7B545A .....ea ..... 9.95

**Equalizer Bar Bushing and Clip Kit**

Includes 2 felt washers, ball bushing (frame mount side) and C-clip, 2-piece socket bushing (engine mount side), and spring clip.  
'71 - '77 8-cylinder.  
⌘ ..... C5AZ-7543CKIT .....kit..... 32.95



**Clutch Equalizer Bar Repair Kit**

Includes 2 felt washers, 2 nylon ball bushings, 2 clevis clips, and 1 metal washer.  
'70 - '77 '70 - '77 Maverick 6-cylinder; '71 Comet 250 / 302.  
⌘ ..... C1DD-7543KIT .....kit..... 14.95



**Clutch Release Lever Rod (J)**

Includes rod, 2 nuts and tip. Adjustable replacement.  
'71 - '74 '71 - '72 302; '73 - '74 6-cylinder with 3-speed M/T.  
..... D3TZ-7521A .....ea ..... 14.95

**Clutch Equalizer Bar-to-Clutch Release Lever Rod Lower Adjustment Swivel**

1 5/8" long, 3/8" hole. Not threaded.  
'70 - '75 Maverick 200 / 250 / 302 before 12/16/74; '71 - '75 Comet 302 before 12/16/74; '72 - '75 Comet 200 / 250 before 12/16/74.  
⌘ ..... D1DZ-7A528A .....ea ..... 16.95

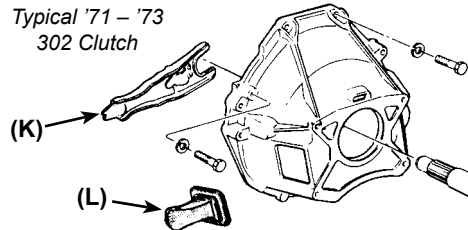

**CLUTCH RELEASE LEVER (FORK) (K)**

This retrofit clutch fork is manufactured to OE standards and features a gold anodized finish. Clip-type.  
'71 - '74 302.  
⌘ ..... D3DZ-7515A .....ea ..... 79.95





**CLUTCH RELEASE LEVER DUST SHIELDS (L)**

SEE DIAGRAM ON PREVIOUS PAGE

'71 - '72	'71 Comet 302; '72 Maverick 302; '72 Comet 250.	
	C6OZ-7513C.....ea	19.95
'73 - '77	6-cylinder.	
	C6GY-7513A.....ea	19.95



**C8OZ-7522A C8AZ-7522A**

**CLUTCH RELEASE LEVER PIVOT BRACKETS**

Attaches to the bellhousing. Includes attaching hardware.

'71 - '72	'72 Maverick; '71 - '72 Comet All with 6-cylinder. L-shaped. 7/8" x 1 1/16" x 1 15/16" wide.	
	C8OZ-7522A.....ea	22.95
'72 - '77	8-cylinder with clip-type lever.	
	C8AZ-7522A.....ea	26.95

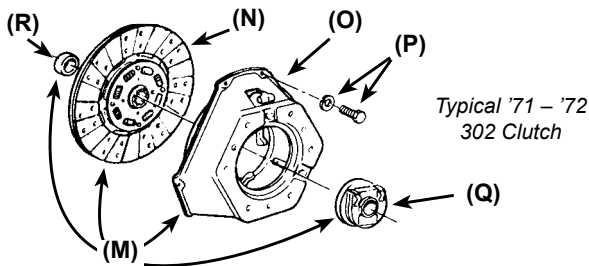

**07-014**



**10578**

**COMPLETE CLUTCH KITS (M)**

Diaphragm style. Kit includes a high quality clutch and disc assembly, release bearing, pilot bearing, and alignment tool.

'70 - '74	'70 - '74 Maverick / Comet 250; '71 - '74 Comet 302. Diaphragm style. 10" O.D. disc with 1 1/16", 10-tooth spline.	
	07-014.....kit	149.95
'71 - '77	Comet 200. Lever style. 9" O.D. disc with 1 5/16", 10-tooth spline.	
	10578.....kit	219.95
'74 - '77	Maverick 250. Diaphragm style. 10" O.D. disc with 1 1/16", 10-tooth spline.	
	..... 90216.....kit	139.95



**10" CLUTCH DISC (N)**

Diaphragm style.



For pressure plate, see part #CF360030 listed below.

For Dual Friction® kit with 90% holding capacity, see part #DF490030 listed below.

Requires throwout bearing #N1714 (see below).

**NOTE:** OE clutch may be 10 1/2".

'73 - '77	250, 302.	
	280490.....ea	179.95



**PRESSURE PLATE (O)**



Offers 30% more holding capacity than a stock OEM clutch, while maintaining a stock pedal feel. This system (#280490 and #CF360030) is recommended as the finest-quality upgrade from the original clutch.

Must be used with clutch disc #280490 (see above).

Requires throwout bearing #N1714 (see below).

'73 - '77	250, 302.	
	CF360030.....ea	249.95



**10" CLUTCH DISC / PRESSURE PLATE SET**



This Centerforce Dual Friction® System generates up to 90% increase in holding capacity over stock systems. Suitable for engines producing high horsepower and torque, as well as for high-performance street vehicles.

Requires throwout bearing #N1714 (see below).

Diaphragm style.

**NOTE:** OE clutch disc may be 10 1/2".

'73 - '77	250, 302.	
	DF490030.....set	449.95



**PRESSURE PLATE BOLTS AND WASHERS (P)**

Includes 6 bolts and 6 washers. 5/16" - 18 x 1".

'70 - '77	V8.....911.....set	14.95
-----------	--------------------	-------



**THROWOUT BEARING (Q)**

Use with Pressure Plate #CF360030, Clutch Disc / Pressure Plate Set #DF490030 and Clutch Disc #280490 (see above).

'73 - '77	250, 302.	
	N1714.....ea	44.95



**PILOT BEARING (R)**

'70 - '73 170, 200, 250, 302 351W; '74 200, 302 before 4/74; '75 - '77 Maverick 200.

	FC65662.....ea	17.95
--	----------------	-------

**Auto Krafters, Inc.**  
is a long-time member of the  
**Specialty Equipment Market Association**



## Front Suspension

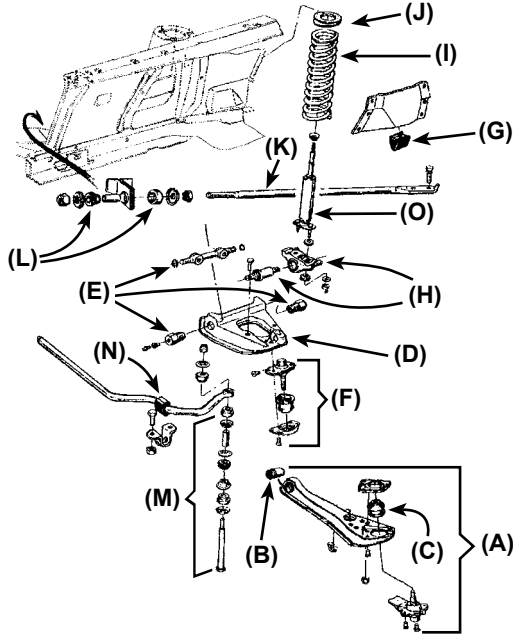

**K8123**      **10812**

### LOWER CONTROL ARM ASSEMBLIES (A)

Includes 3 cotter pins, 2 washers, 1 castle nut, and 1 grease fitting.

'70 - '77	<b>Moog</b>			
		K8123	ea	69.95
	<b>Import</b>			
		10812	ea	59.95
	<b>Heavy-Duty</b>			
	Has a reinforcement plate welded on the bottom for extra support.			
	<b>NEW</b>	D1OZ-3078HD	ea	89.95



**FB365**      **43102G**

### LOWER CONTROL ARM SHAFT BUSHINGS (B)

Used with lower control arm shaft kit #K8243A below.

#### With Metal Shells

Requires 2 per vehicle.

'70 - '77	1 7/16" O.D.			
		12268	ea	18.95
	1 7/16" O.D.			
		FB292	ea	18.95
	1 9/16" O.D.			
		FB365	ea	14.95

#### Without Metal Shells

Urethane. Must reuse existing outer metal shells.

'70 - '77	1 7/16" O.D.			
		43102G	set	19.95
	1 9/16" O.D.			
		43106G	set	19.95



### LOWER CONTROL ARM SHAFT KIT

Includes 2 shafts, 2 cams, 2 nuts, and 2 washers. Used for camber adjustment. Kit does 1 vehicle.

'70 - '77		K8243A	kit	28.95
-----------	--	--------	-----	-------



### LOWER BALL JOINT DUST BOOT COVER (C)

'70 - '77 Maverick after 7/14/69; '71 Comet.

	C7OZ-3A105A	ea	8.95
--	-------------	----	------

**C7OZ-3082**



**13173A**

### UPPER CONTROL ARM ASSEMBLIES (D)

Aftermarket. 3-rivet ball joint with natural rubber boot. Import.

'70 - '77	<b>Moog</b>			
		C7OZ-3082	ea	84.95

#### Heavy-Duty

Upgraded heavy-duty shaft assembly with rubber bushings.



		C7OZ-3082HD	ea	99.95
--	--	-------------	----	-------

### UPPER CONTROL ARM SHAFT KIT (E)

Includes the upper control arm shaft, 2 bolts, 2 nuts, 2 large bushings, 2 o-rings, and 2 grease fittings. Moog.

'70 - '77	Requires 2 kits per vehicle.			
		13173A	kit	49.95



### UPPER CONTROL ARM GREASE FITTING KIT

Eliminate squeaking from dry hard-to-reach upper control arm bushings. Regular 90°

fittings do not fit between the control arm and the shock tower wall. Our special 2-piece 90° grease fittings eliminate the need to destroy shock towers in order to inject grease into these bushings. Includes positioning wrench (for access where space is limited), instructions, and 4 fittings.

'70 - '77		610-041	kit	19.95
-----------	--	---------	-----	-------



**K8036**

**10230AB**



**K8142**

**10235**

### UPPER BALL JOINTS (F)

Includes mounting hardware.

'70	Before 7/14/69.			
	4 bolt.			
		K8036	ea	39.95
		10230AB	ea	19.95
'70 - '77	Maverick after 7/14/69; '71 - '77 Comet.			
	3 bolt.			
		Moog.		
		K8142	ea	39.95
		Import.		
		10235	ea	19.95



### UPPER FRONT SUSPENSION BUMPER (G)

Mounts on outer shock tower / coil spring cover. Rubber. Includes nut.

'70 - '77 requires 2 per vehicle.

	C9OZ-3020	ea	9.95
--	-----------	----	------



**BF** Boxing Fee



**OS** Oversize



**TF** Truck Freight



**C4DZ-3388A**



**C4DZ-3388RR**

**FRONT COIL SPRING SEATS (H)**

SEE DIAGRAM ON PREVIOUS PAGE

Bolts to upper control arm. Includes bushing.

- '70 - '77 Replacement. Black.  
 ..... C4DZ-3388A .....ea ..... 29.95  
 Aftermarket. Gold anodized with red nitrile rubber bushing and insulators.  
 ..... C4DZ-3388RR .....ea ..... 39.95

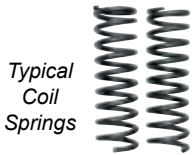

Typical Coil Springs



**C4DZ-5415A**



**C4DZ-5415U**

**COIL SPRINGS (I)**

SEE DIAGRAM ON PREVIOUS PAGE

Standard springs. Please specify year, engine size, and with or without Grabber option when ordering. Sold in pairs.

**NOTE:** These are oversized items. Additional shipping charges apply.

- '70 - '77 ..... starts at ..... 99.95



**COIL SPRING TOP INSULATORS (J)**

SEE DIAGRAM ON PREVIOUS PAGE

- '70 - '77 Rubber.  
 ..... C4DZ-5415A .....ea ..... 5.95  
 Polyurethane. Set of 2.  
 ..... C4DZ-5415U .....pr ..... 21.95



**FRONT COIL SPRING COMPRESSOR TOOL**

When used properly, this tool makes removal and installation of coil springs easier. Includes instruction sheets (please read all instructions very carefully and pay attention to safety procedures). Made in USA.

- '70 - '77  
 ..... 6080CSC .....ea ..... 119.95



**STRUT ROD (K)**

Made as original. Does include the nut and pin.

For bushing kit, see part #K8157 or #47112G (previous page).

- '70 - '77 LH.  
 ..... C8OZ-3468B .....ea ..... 49.95  
 RH not available.



**K8157**

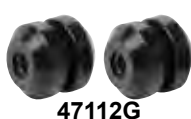

**47112G**

**STRUT ROD BUSHING KITS (L)**

SEE DIAGRAM ON PREVIOUS PAGE

- '70 - '77 With midolyne bushings. Includes hardware.  
 ..... K8157 .....kit ..... 26.95  
 With polyurethane bushings. Does not include hardware.  
 ..... 47112G .....kit ..... 29.95

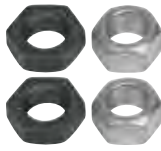

**STRUT ROD NUT SET**

For the under-body end of the strut rod. Includes 2 inner nuts (1 1/16" - 18 x 1 1/8", serrated) and 2 outer nuts (1 1/16" - 18 x 1").

- '71 - '77  
 ..... AK1031 .....set ..... 14.95



**K8097**



**98117G**



**K700528**

**SWAY BAR END LINK KITS (M)**

SEE DIAGRAM ON PREVIOUS PAGE

Includes 1 bolt, 4 bushings, 4 washers, 1 sleeve, and nut(s). Requires 2 kits per vehicle.

**Rubber Bushings**

- '70 - '76  
 ..... K8097 .....kit ..... 9.95  
 '76 - '77  
 ..... K440 .....kit ..... 8.95

**Polyurethane Bushings**

- '70 - '77  
 ..... 98117G .....kit ..... 24.95  
 '76 - '77  
 ..... Moog replacement. Made in the USA.  
 Features include a grade-8, 3/8" - 16 x 5.50" bolt, bolt-on end piece, hex spacer (1.620"), 3 flat washers, and 4 white polyurethane bushings of improved design for high-stress durability and better oil and heat resistance.  
 ..... K700528 .....kit ..... 9.95

**SWAY BAR MOUNTS (N) SEE DIAGRAM ON PREVIOUS PAGE**



**54935/8**



**54937/8**

**Without Brackets**

Rubber bushings only.

- '70 - '77 With 5/8" bar ..... 54935/8 .....pr ..... 14.95  
 With 1 1/16" bar ..... 549311/16 .....pr ..... 14.95  
 With 3/4" bar ..... 54933/4 .....pr ..... 14.95  
 With 7/8" bar ..... 54937/8 .....pr ..... 20.95  
 With 1 5/16" bar ..... 549315/16 .....pr ..... 20.95  
 With 1" bar ..... 54931 .....pr ..... 14.95



- '70 - '77 With 5/8" to 1 1/16" bar.  
 ..... K5227 .....pr ..... 10.95



**95105G**



**95108G**

**With Brackets**

Polyurethane. Includes brackets and bushings.

- '70 - '77 With 1 1/16" bar.  
**NOTE:** Must drill new holes. The brackets do not line up.  
 ..... 95105G .....kit ..... 22.95  
 With 3/4" bar.  
**NOTE:** Must drill new holes. The brackets do not line up.  
 ..... 95106G .....kit ..... 22.95  
 With 7/8" bar.  
 ..... 95108G .....kit ..... 22.95

**SWAY BAR MOUNTS CONTINUED**

**With Brackets Continued**

'70 - '77	With 1 <sup>5</sup> / <sub>16</sub> " bar	95109G	kit	22.95
	With 1" bar	95110G	kit	22.95
	With 1 <sup>1</sup> / <sub>8</sub> " bar	95112G	kit	22.95



**FRONT SUSPENSION LOWER CROSSMEMBER**

Improves handling by giving greater stability and more strength in the front end. Fits

under the vehicle and bolts to the under-side of the frame rail, just behind the shock tower.

'71 - '77	302.			
		D0DZ-5025A	ea	79.95

**SHOCKS (O) SEE DIAGRAM ON PAGE 67**

**NOTE:** Shock absorbers contain compressed gases and must be shipped using only ground services. No air shipments will be allowed.



**Monroe-Matic Plus® Gas Shocks**



Combines exclusive position-sensitive pressure tube grooves with specially-tuned valving to improve ride and handling. Adapts more rapidly to changing road and weight conditions.

'70 - '77	Front.			
		KY33059	ea	29.95
	Rear.			
		KY32103	ea	29.50



**Max-Air® Gas Shocks**



Features large air chambers that inflate up to 150 PSI. Contains all-weather fluid that ensures smooth reaction for the 1/2" piston rod. Features sintered iron pistons for durability and air fittings that resist air leakage. Includes mounting hardware and air line installation kit.

'70 - '77	Rear.			
		MA709	ea	89.95



**Max Air® Hose Kit**

This air line installation kit will work with most Monroe® Max-Air® shock absorber sets. Kit includes the air lines, anchors, caps, plastic fittings, and o-rings. Made in USA.

<b>NEW</b>		AK29	kit	19.95
------------	--	------	-----	-------



**Gabriel® Shocks**



Tuned to the specific needs of your vehicle. Provides a real step up in performance and handling. Includes hardware.

**NOTE:** Shocks may be painted red or blue.

'70 - '77	Front.			
		81076	ea	34.95
	Rear.			
		82130	ea	34.95

**SHOCKS CONTINUED**



**KYB® Excel-G Premium Shocks**



Designed to compensate for worn suspensions and built with components and valving for these specific applications. Your best choice for OE replacement and normal driving conditions. Made in Japan.

'70 - '77	Front.			
		343146	ea	39.95
	Rear.			
		343136	ea	49.95



**Performance Gas-Charged Shock**



Get improved handling and control with this performance-tuned shock absorber. Its highly-efficient design delivers superior, consistent performance compared to traditional shocks. Developed for the classic Ford owner seeking sporty handling without a punishing ride. Includes high-quality rubber bushings and locking nuts.

'70 - '77	Front.			
		D0DZ-18124HP	ea	39.95

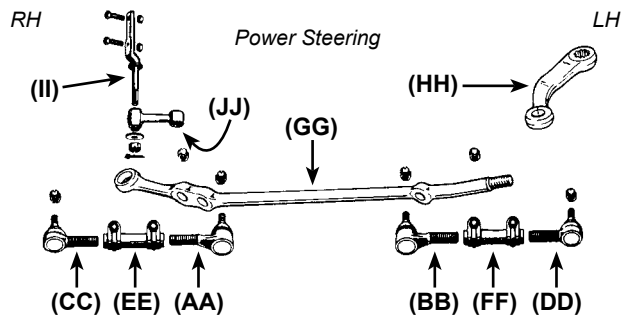
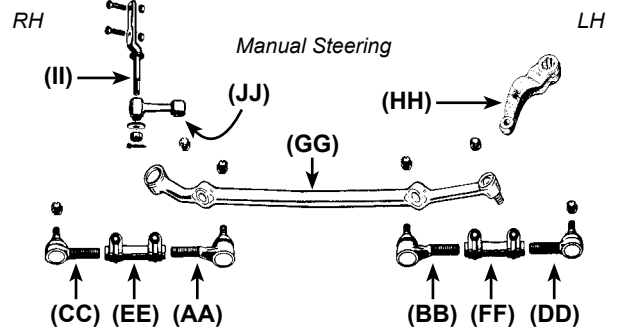

ES387L



ES387R

**TIE ROD ENDS**

Includes cotter pin, castle nut, grease fitting, and dust boot.

'70 - '74	Inner. LH or RH.			
	(AA) (BB)	ES387L	ea	69.95
		Import.		
	(AA) (BB)	D0ZZ-3A131B	ea	22.95
'70 - '74	Outer. LH or RH.			
	Moog.			
	(CC) (DD)	ES387R	ea	39.95
		Import.		
	<b>NEW</b> (CC) (DD)	D0OZ-3A130B	ea	19.95



ES436L



ES445RL

**TIE ROD ENDS CONTINUED**

SEE DIAGRAM ON PREVIOUS PAGE

'75 - '77	Inner. LH or RH.	(AA) (BB)..... ES436L.....ea	49.95
	Outer. LH or RH.	(CC) (DD)..... ES445RL.....ea	29.95

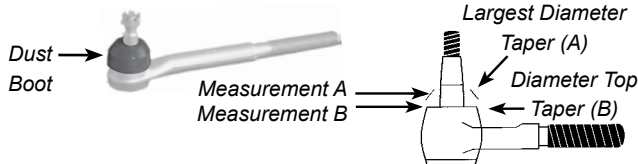

913101G

**TIE ROD END DUST BOOTS - POLYURETHANE**

Replace your tie rod dust boot without having to buy a new tie rod end. Made from high-quality black polyurethane, these new dust boots will help resist damage from rocks, sand, water, road salt, and oils by sealing the tie rod end to prevent loss of lubricants - the major cause of tie rod wear.

Measure the rod end per the diagram shown to find the closest fit.

'70 - '77	Dimension A = 3 <sup>1</sup> / <sub>64</sub> " or .472" or 12 mm. Dimension B = 1 <sup>13</sup> / <sub>64</sub> " or 1.200" or 30.5 mm.	913103G.....pr	5.95
'70 - '77	Dimension A = 1 <sup>9</sup> / <sub>64</sub> " or .590" or 15 mm. Dimension B = 1 <sup>3</sup> / <sub>8</sub> " or 1.375" or 35 mm.	913101G.....pr	5.95



ES2004S



ES426S

**TIE ROD END CONNECTING SLEEVES (EE) (FF)**

SEE DIAGRAM ON PREVIOUS PAGE

Includes 2 nuts and 2 bolts. Required 2 per vehicle.

'70 - '72	Maverick; '71 - '72 Comet. LH or RH.	ES2004S.....ea	9.95
'72 - '77	LH or RH.	ES426S.....ea	14.95



D0DZ-3304



RP25881



RP25914

**CENTER LINKS (DRAG LINKS) (GG)**

SEE DIAGRAM ON PREVIOUS PAGE

'70 - '74	M/S. Reproduction.	D0DZ-3304.....ea	149.95
'75 - '77	M/S. No core required.	RP25881.....ea	139.95
'75 - '77	P/S.	RP25914.....ea	106.95
	Core fee	RP25914CORE.....ea	100.00



**PITMAN ARM (HH)**

SEE DIAGRAM ON PREVIOUS PAGE

'75 - '77	M/S.	RP20130.....ea	99.95
-----------	------	----------------	-------



**PITMAN ARM-TO-STEERING GEAR NUT**

Holds the pitman arm to the steering gear sector shaft. 7/8" - 14, 1<sup>5</sup>/<sub>16</sub>" hex.

'70 - '77	With 1 1/8" sector shaft.	AK1032.....ea	4.95
-----------	---------------------------	---------------	------



K8150



K8245



K8103

**IDLER ARM ASSEMBLIES (II)**

SEE DIAGRAM ON PREVIOUS PAGE

'70 - '72	Maverick; '71 - '72 Comet.	K8150.....ea	69.95
'75 - '77		K8245.....ea	49.95

**IDLER ARM BUSHING (JJ)**

SEE DIAGRAM ON PREVIOUS PAGE

Center link end.

'70 - '77		K8103.....ea	14.95
-----------	--	--------------	-------

**Rebuilt Power Steering Components**

These premium remanufactured units carry a manufacturer's limited lifetime warranty against defects in material or workmanship for as long as you own your vehicle. We will repair or replace ANY remanufactured steering component found to be defective due to the failure of material or workmanship in our judgment. This warranty does NOT cover operator negligence, misuse, accidents, improper installation, changes in adjustments or disassembly.

If you do not have a unit to be rebuilt, call our Rebuild Department for availability of a rebuildable core. Please allow 3 to 4 weeks *plus shipping time* to rebuild the unit. Core fees are in addition to the price of the unit and are refundable in 3 to 4 weeks after receiving a rebuildable core.

**\* ALL CORES MUST BE RETURNED COMPLETE WITHIN 60 DAYS TO RECEIVE A FULL REFUND \***

**NOTE:** There will be an additional cost for replacement parts, such as ball stud, end cap, worm gear, or sector shaft.



CV8535 / CV8536



CV8535  
Port Detail



CV8536  
Port Detail

**CONTROL VALVE REBUILDS**

If your control valve needs the ball stud or end cap replaced, you will be notified. Additional cost for the ball stud is \$20.00, additional cost for the end cap is \$24.00.

'70 - '76	Before 4/5/76. Flared fitting.	CV8535.....ea	189.95
	Core for above	CV8535CORE.....	200.00
'76 - '77	After 4/5/76. O-ring fitting.	CV8536.....ea	189.95
	Core for above	CV8536CORE.....	150.00





**POWER CYLINDER REBUILD**

When necessary, shafts are replaced at no extra charge. Rebuild includes boot insulator kit #C3AZ-3C651A below.

**NOTE:** Customer must supply core to be rebuilt.

'70 - '77 ..... PCRB .....ea ..... 189.95



**POWER CYLINDER BOOT INSULATOR KIT**

Accordion-type sleeve, approximately 9" long but compresses to 3", extends to 12". Includes 2 washers, 2 bushings, and 1 retaining ring.

**NOTE:** This kit is included as part of the power cylinder rebuild above.

'70 - '77 ..... C3AZ-3C651A .....kit..... 16.95



**POWER CYLINDER SEAL KIT**

Includes all the necessary seals and bushings when a power cylinder rebuild is done.

'70 - '77 ..... 2745 .....kit..... 19.95



**POWER CYLINDER BALL STUD END BOOT AND CLAMP**

'70 - '71

..... C5ZZ-3A540B .....ea ..... 14.95



**STEERING COUPLER REPLACEMENT KIT (RAG JOINT)**

Helps prevent steering wheel shimmy and vibration, and tightens up loose steering. Kit includes disc, nuts, bolts, and washers. Requires 1 kit.

'70 - '77 ..... 31000 .....kit..... 12.95

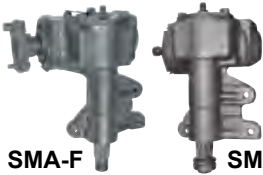

**REMANUFACTURED STEERING GEAR BOXES**

Rebuild consists of new bushings, bearings and seals. The worm gear and sector shaft are polished and inspected to ensure quality, and the gear box is set to original specifications. If the worm gear or sector shaft need replacing, you will be notified. If available, these parts can be replaced for an additional charge.

**\*\* MUST HAVE TAG NUMBER READY WHEN ORDERING \*\***

'70 - '77 7<sup>3</sup>/<sub>16</sub>" input shaft.  
M/S.  
 ..... SMA-F .....ea ..... 219.95  
Core fee .....ea ..... 150.00  
P/S.  
 ..... SMA-B .....ea ..... 229.00  
Core fee .....ea ..... 150.00



**POWER STEERING PUMP REBUILDS**

'75 6-cylinder..... P136 .....ea ..... 119.95  
Core for above ..... P136CORE .....ea ..... 100.00



P313

P308

**POWER STEERING PUMP REBUILDS CONTINUED**

'76 - '77 6-cylinder.  
Flared fitting ..... P307 .....ea ..... 119.95  
Core for above ..... P307CORE .....ea ..... 75.00  
'76 - '77 V8.  
Flared fitting ..... P313 .....ea ..... 119.95  
Core for above ..... P313CORE .....ea ..... 75.00  
O-ring fitting..... P308 .....ea ..... 119.95  
Core for above ..... P308CORE .....ea ..... 75.00

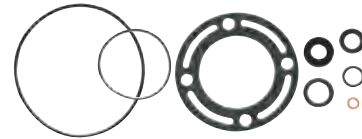

**POWER STEERING PUMP SEAL REPAIR KIT**

'70 - '77 With Ford pump.  
 ..... 2773 .....kit..... 19.95

**New Power Steering Components**

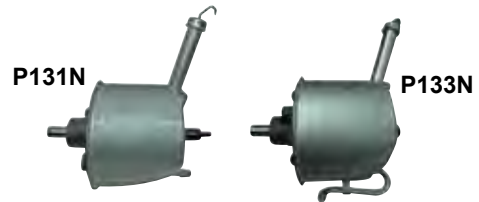

P131N

P133N

**NEW POWER STEERING PUMPS**

Ford-type pumps with correct canister.

'70 - '74 6-cylinder.  
 ..... P131N .....ea ..... 157.50  
'71 - '75 '71 - '74 8-cylinder; '75 8-cylinder without A/C.  
Has female pressure port.  
 ..... P133N .....ea ..... 157.50



**POWER STEERING PUMP ADJUSTING BRACKET**

'70 - '77 Maverick 170, 200; '71 - '77 Comet 170, 200.

..... C7SZ-3A732A .....ea ..... 59.95



C7AZ-3A006B



C7AZ-3A006C

**POWER STEERING PUMP CAPS AND DIPSTICKS**

'71 - '72 Comet.  
Zinc.  
 ..... C7AZ-3A006B .....ea ..... 16.95  
Chrome.  
 ..... C7AZ-3A006C .....ea ..... 19.95



**NEW CONTROL VALVE**

New, not remanufactured. No core fee.

'70 - '76 ..... FR8535 .....ea ..... 269.95

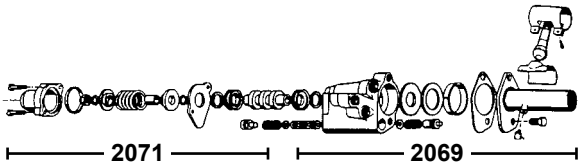

**POWER STEERING CONTROL VALVE REPAIR KITS**

**Control Valve Seal Kit**

Includes all the necessary seals required when a control valve rebuild is done. Kit includes paper seal, 2 plastic washers, 3 o-rings, nut, 2 rubber seals, and 2 rubber grommets.

'70 - '77 ..... 2071 ..... kit ..... 19.95

**Control Valve Ball Stud Kit**

Kit includes spring, 2 ball stud seats, ball stud, bracket, 2 screws, and 3 gaskets.

'70 - '77 ..... 2069 ..... kit ..... 34.95



**Control Valve Seal and Ball Stud Repair Kit**

Combines seal kit #2071 and stud kit #2069 (above). Includes all the necessary seals required when a control valve rebuilt, plus the ball stud, ball stud seats, spring, ball stud seal and bracket with screws. Ball stud socket sold separately (see part #C1AA-3A754C below).

'70 - '77 ..... 5060KIT ..... kit ..... 49.95



**POWER STEERING CONTROL VALVE SOCKET BALL STUD**

'70 - '72 ..... C1AA-3A754C ..... ea ..... 23.95



**POWER STEERING CONTROL VALVE TUBE SEATS**

Aluminum. Includes (3) 5/16" tube seats and (1) 3/8" tube seat.

'70 - '76 ..... 372896/373430SET ..... set ..... 16.95



**POWER STEERING CONTROL VALVE END CAP**

Aluminum end cap used on all control valves.

'70 - '77 ..... CVENDCAP ..... ea ..... 24.00



**POWER-TO-MANUAL STEERING CONTROL VALVE ELIMINATOR**

A hassle-free, economical method for converting from power steering to manual steering. Simply remove the control valve and thread this adapter on in its place. Complete with instructions and is ready to install. Greaseable and includes an original-looking rubber seal.

'70 - '77 ..... '70 - '77 Maverick with P/S; '71 - '75 Comet with P/S. RP27483 ..... ea ..... 149.95

**Not sure of a term used here?**

**Check out the Glossary in the back of this catalog.**

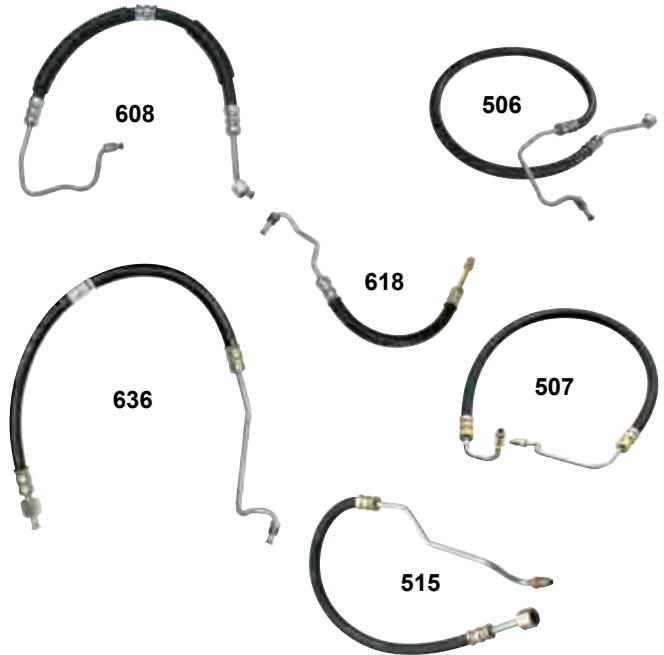

**POWER STEERING HOSES**

**Pressure Hoses**

- '70 - '74 '70 - '72 170, 200, 250; '73 - '74 250. 36 1/2" long with 3/8" female S.A.E. x 5/16" male inverted flare. ..... 608 ..... ea ..... 29.95
- '70 - '75 250 without hydro-boost. 51 3/4" long with 3/8" female S.A.E. x 5/16" male inverted flare. Flared fitting. ..... 506 ..... ea ..... 39.95
- '71 - '74 302. 22" long with 3/8" male inverted flare x 3/8" male S.A.E. Pump end. ..... 618 ..... ea ..... 29.95
- '71 - '75 302. 30" long with 3/8" female S.A.E. x 5/16" male inverted flare. Valve end. ..... 636 ..... ea ..... 29.95
- '75 250. Flared fitting. 51 3/4" long with 3/8" female S.A.E. x 5/16" male inverted flare. ..... 506 ..... ea ..... 39.95
- '75 8-cylinder. Valve end. 30" long with 3/8" female S.A.E. x 5/16" male inverted flare. ..... 636 ..... ea ..... 29.95
- '76 200, 250 before 4/5/76 without hydro-boost. Flared fitting. 51 3/4" long with 3/8" female S.A.E. x 5/16" male inverted flare. ..... 506 ..... ea ..... 39.95
- '76 302 with o-ring pump and flared gear fittings or flared pump and gear fittings. Fits to gear. 30" long with 3/8" female S.A.E. x 5/16" male inverted flare. Valve end. ..... 636 ..... ea ..... 29.95
- '76 6-cylinder after 4/5/76 with o-ring fittings. 40 1/2" long, 3/8" male o-ring x 5/16" male o-ring. ..... 507 ..... ea ..... 34.95
- '76 302 after 5/6/76 with o-ring fittings. Valve end. 30 1/2" long x 3/8" female S.A.E. x 5/16" male o-ring. ..... 515 ..... ea ..... 29.95
- '77 6-cylinder. 40 1/2" long, 3/8" male o-ring x 5/16" male o-ring. ..... 507 ..... ea ..... 34.95
- '77 302. Valve end. 30 1/2" long x 3/8" female S.A.E. x 5/16" male o-ring. ..... 515 ..... ea ..... 29.95



**POWER STEERING HOSES CONTINUED**



**Return Hoses**

'70 - '74	Maverick all 6-cylinder; Comet 170, 200, 250. 55½" long with ¾" male inverted flare.	817	ea	24.95
'71 - '75	8-cylinder. Valve end, return from gear. 32¾" long with ¾" male inverted flare × ¾" bead.	651	ea	24.95
'71 - '77	Maverick 302	491	ea	22.95
'73 - '74	8-cylinder. Cooler to pump.	903-9	ea	8.95
'75	200, 250. 55½" long with ¾" male inverted flare.	817	ea	24.95
'76	8-cylinder before 1/5/76 with flared gear fitting. From gear. 32¾" long with ¾" male inverted flare × ¾" bead. Valve end.	651	ea	24.95
'76	200, 250 with flared fitting. 55½" long with ¾" male inverted flare.	817	ea	24.95
'76	302 with o-ring fittings. From gear. 33¼" long with ¾" male o-ring × ¾" bead.	519	ea	19.95
'77	302. From gear. 33¼" long with ¾" male o-ring × ¾" bead.	519	ea	19.95



**Control Valve-to-Cylinder Hoses**

'70 - '74	9½" long with 5/16" male inverted flare × 5/16" male inverted flare. Composed of one #C6OZ-3A714A (to cylinder) hose and one #C6OZ-3A717A (to control valve) hose. Requires 1 pair per vehicle.	C6OZ-3A714/7PR	pr	59.95
'76	200, 250 after 4/5/76; 302 from 1/5/76 to 5/6/76 o-ring fitting. Requires 2. 10¾" long with 5/16" male o-ring × 5/16" male o-ring.	523	ea	19.95
'77	302. Pump end.	523	ea	19.95



**POWER STEERING HOSE INSULATOR**

Molded rubber, which resists hardening and cracking.  
'71 - '72 Maverick; '73 - '75 Maverick without hydro-boost and skid control; '76 - '77 Maverick; '71 Comet.  
C7ZZ-3A609A .....ea ..... 9.95



**STEERING COLUMN LOWER FLANGE BEARING**

Aluminum housing and press-fit sealed bearing. 2.115" O.D. × .75" I.D. × .902" deep. Replaces the O.E. plastic bearing or the rubber flange insulator in the column. Can also be used in vehicles that had the felt seal.

Helps restore smooth steering and eliminated a steering wheel vibration. Includes stainless mounting hardware for a finished look.

**NOTE:** Will fit many applications—check the dimensions of your steering column shaft and tube to verify fit.

.....	3517	.....ea	64.95
-------	------	---------	-------

**INTEGRAL POWER STEERING CONVERSION KITS**

Upgrade your stock steering with these complete integral power steering conversion kits. Kits include all components necessary for conversion.

**IMPORTANT INSTALLATION NOTES:**

- Steering column must be shortened to fit conversion box.
- Steering column modifications can be extensive on column shift cars.
- Power conversion box will not fit with factory clutch linkage.
- Does not include instructions. We recommend an experienced person with the understanding of modifications to do this installation.



**Manual-to-Power Kit**

Upgrades manual steering to integral power steering.

Kit includes integral power steering box, universal joint / rag joint, power steering pump kit (pump, mounting bracket, pulley), and hose kit.

'70 - '77	289, 302, 351W.	6571FARKTMS8	.....kit	999.00
-----------	-----------------	--------------	----------	--------



**Power Assist-to-Integral Power Kit**

Upgrades power assist steering to integral power steering. Eliminates the power cylinder and control valve, and replaces the manual steering box with an integral power steering box.

Kit includes integral power steering box, rag joint, hose kit, and drag link adapter.

'70 - '77	289, 302, 351W.	6671FARKTPS8	.....kit	869.00
-----------	-----------------	--------------	----------	--------

## Rear Suspension

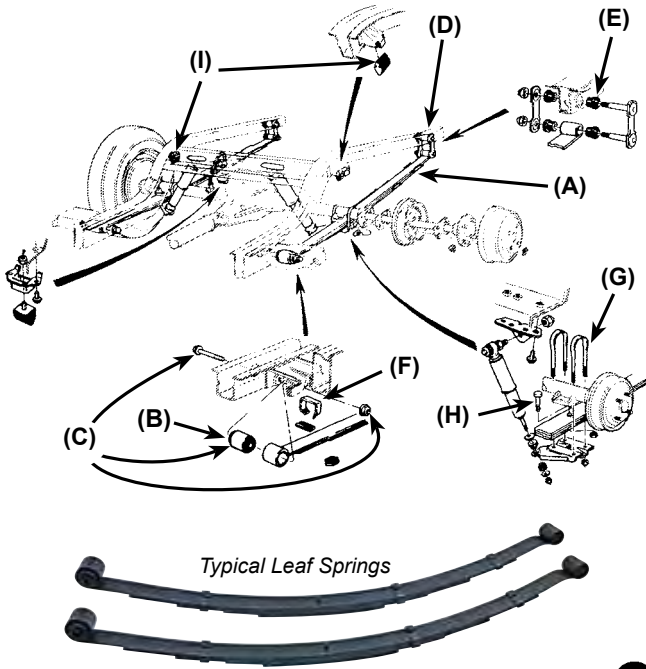

### REAR LEAF SPRINGS (A)

Made in the USA. Please specify year, model, engine size, with or without A/C, and number of leaves when ordering.

**NOTE:** These are oversized items. Additional shipping charges apply.

'70 - '77 ..... starts at .... 299.95

### FRONT OF LEAF SPRING BUSHING (B)

Requires 2 per vehicle.

'70 - '77 ..... RB82 ..... ea ..... 16.95

### FRONT OF REAR LEAF SPRING MOUNT KIT (C)

Includes bolt, bushing, and nut. Requires 2 per vehicle.

'70 - '73 ..... F53 ..... kit ..... 24.95



FS772



FS1008

### REAR LEAF SPRING SHACKLE KITS (D)

Requires 2 kits per vehicle.

'70 - '73 Measures 3 1/2" inches center-to-center. Bushing size: 6 3/64" inch. Uncoated.

..... D1OZ-5630AR ..... kit ..... 29.95

Black powder-coated.

..... FS772 ..... kit ..... 29.95

'74 - '77 4" center to center. Includes 4 bushings and 2 nuts.

..... FS1008 ..... kit ..... 49.95

### REAR LEAF SPRING SHACKLE KITS CONTINUED

'75 - '77 Measures 3 1/2" inches center-to-center. Bushing size: 6 3/64" inch.

Uncoated.

..... D1OZ-5630AR ..... kit ..... 29.95

Black powder-coated.

..... FS772 ..... kit ..... 29.95



### REAR LEAF SPRING SHACKLE BUSHING (E)

Requires 8 per vehicle.

'70 - '77

..... HB1059 ..... ea ..... 2.95



### REAR LEAF SPRING BAND CLAMP SET (F)

Includes 2 short bands, 2 medium bands, 2 long bands, and 6 rubber insulators. Used with 2 1/2" wide spring with 4 leaves.

'71 - '72 ..... C4DZ-5724A ..... ea ..... 39.95

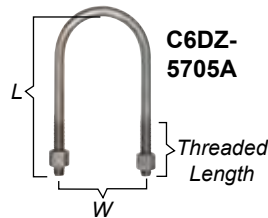

C6DZ-5705A



D5DZ-5705A

### REAR SPRING U-BOLTS (G)

Includes nuts. Requires 4 per vehicle.

**NOTE:** Please verify the measurements of your u-bolt before ordering. To get u-bolt width, measure plate holes center to center.

'70 - '74 '70 - '74 Maverick; '71 - '72 Comet.

5 7/8" long, top inside to end; 3 1/4" wide, center to center. Bolt size: 7/16" - 20 threads / inch x 2" threaded length.

..... C6DZ-5705A ..... ea ..... 9.95

'75 - '77

6" long, top inside to end; 2 3/4" wide, center to center. Bolt size: 7/16" - 20 threads / inch x 2 1/8" threaded length.

..... D5DZ-5705A ..... ea ..... 8.95



### REAR LEAF SPRING CENTER BOLTS (H)

Correct center bolts that hold together the leaves of the rear leaf springs. 5/16" - 24 x 1.39", .5" O.D. Package of 2 bolts, 2 nuts and 2 washers. Requires 1 package per vehicle.

..... 378683SKT ..... kit ..... 9.95



### SUPERIOR AUTOMOTIVE RIDE EFFEX 500 LIFT KIT

Fits most vehicles with rear leaf springs. This set of rear shackle bars is easy to install and has three adjustable positions to provide additional fender and tire clearance. Includes (4) shackle bars; (4) installation bolts with nuts and washers; installation instruction sheet.

'70 - '77 ..... 134000 ..... kit ..... 39.95



### REAR AXLE BUMPER (I)

Requires 2 per vehicle.

'70 - '74 Maverick; '71 - '73 Comet.

..... C6AZ-4730A ..... ea ..... 8.95

**BF** Boxing Fee

**OS** Oversize

**TF** Truck Freight



**BRAKE BOOSTER CHECK VALVE**  
'75 - '77 with Bendix booster.  
..... D0AZ-2365A .....ea ..... 8.95



**BRAKE BOOSTER  
PUSH ROD-TO-FIREWALL BOOT**  
'70 - '71  
..... RP32AA .....ea ..... 9.95

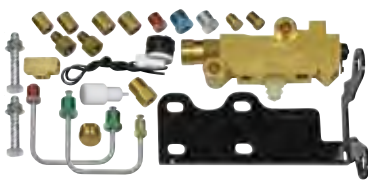

**VL3350KF**



**VL3359KN**

**BRAKE PROPORTIONING VALVE KITS**

Features a fluid metering pressure failure indicator as well as pressure proportioning function. Includes valve, bracket, fittings, brass tee, switch plug with wire, and bleeder plugs. Universal kits; can be used as a replacement.

'70 - '77 With disc / drum brakes.  
Also includes master cylinder lines.  
..... VL3350KF .....kit..... 159.95  
'70 - '77 With disc / disc brakes.  
..... VL3359KN .....kit..... 159.95



**DISC BRAKE PROPORTIONING VALVE**  
Adjustable replacement; not like OEM. Requires modified brake lines.  
'70 - '77 with front disc brakes.  
..... A0707 .....ea ..... 49.95



**C5ZZ-2B257A**



**C7ZZ-2B257A**

**BRAKE DISTRIBUTION VALVES**

**NOTE:** May not be an exact replacement. May require bending or replacement of brake lines.

For conversion from single-reservoir to dual-reservoir master cylinder.  
Does not include brake pressure differential valve warning lamp switch.

**NEW** ..... C5ZZ-2B257A .....ea ..... 89.95

With drum / drum brakes and dual-reservoir master cylinder. Includes brake pressure differential valve warning lamp switch.

**NOTE:** This valve will work on 1953-77 Fords, but the brake pressure differential warning lamp switch is a dual-prong type for 1968-77 Fords.

..... C7ZZ-2B257A .....ea ..... 99.95



**C8AZ-2B264A**



**D5AZ-2B264A**

**BRAKE PRESSURE DIFFERENTIAL VALVE  
WARNING LAMP SWITCHES**

'70 Before 7/14/69..... C8AZ-2B264A .....ea ..... 34.95  
'73 - '77 Maverick; '75 - '77 Comet.  
..... D5AZ-2B264A .....ea ..... 34.95



**MASTER CYLINDER  
PUSH ROD BOOT**  
'70 - '73 with drum brakes.  
..... OA-2180 .....ea ..... 6.95



**MASTER CYLINDER PUSH ROD BUSHING**  
'71 - '73  
..... C9AZ-2474A .....ea ..... 5.95



**MC39495**



**MC36440**



**D6FZ-2140C**

**MASTER CYLINDERS - NEW**

'70 - '73 '70 - '73 Maverick all; '71 - '73 Comet without power brakes. Dual reservoir.  
..... MC39495 .....ea ..... 79.95  
'74 - '77 1 5/16" bore.  
With manual front drum or manual front disc brakes.  
..... MC36440 .....ea ..... 69.95  
With power front disc brakes.  
..... D6FZ-2140C .....ea ..... 49.95

**SINGLE RESERVOIR-TO-DUAL RESERVOIR MASTER  
CYLINDER CONVERSION KITS AND SWITCH KIT**



**MC1504K**

**Conversion Kits**

Use these kits to change from power to manual brakes or from single-reservoir master cylinder to dual. Includes dual-reservoir master cylinder with manual rod only. Limited 1-year manufacturer's warranty.

**NOTE:** Vehicles with the brake lamp switch mounted on pedal arm must be changed to an inline tee and switch (see part #HW2003 below).

'70 - '73 With drum brakes ... MC1504K .....kit..... 99.95  
With disc brakes ..... MC1502K .....kit..... 119.95



**Brake Lamp Switch and T Kit**

3/8" - 24 threads. Recommended for use with part #MC1504K and #MC1502K (see above).

'70 - '73 ..... HW2003 .....kit..... 39.95



**C7AZ-2162A**



**D3AZ-2162A**

**MASTER CYLINDER CAPS**

'70 - '73 With drum brakes before 1/15/73.  
Chrome. Includes gasket.  
..... C7AZ-2162A .....ea ..... 22.95  
'70 - '73 With manual drum brakes before 1/15/73.  
Cadmium.  
..... D3AZ-2162A .....ea ..... 19.95



**42068**



**42069**

**MASTER CYLINDER CAP GASKETS**

'70 - '73 Before 1/15/73.  
..... 42068 .....ea ..... 9.95  
'74 - '77 ..... 42069 .....ea ..... 6.95



**C7OZ-2078A**

**SP4959**

**BRAKE HOSES – RUBBER**

**Front Drum**

'71 – '73	..... C7OZ-2078A.....ea	..... 19.95
'74 – '75	..... SP5290.....ea	..... 19.95

**Front Disc**

'74 – '77	All..... SP4959.....ea	..... 19.95
-----------	------------------------	-------------

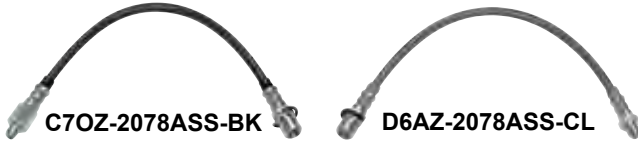

**C7OZ-2078ASS-BK**

**D6AZ-2078ASS-CL**

**BRAKE HOSES – BRAIDED STAINLESS STEEL**

**Front Drum**

'71 – '73	Black jacket..... C7OZ-2078ASS-BK.....ea	..... 34.95
	Clear jacket..... C7OZ-2078ASS-CL.....ea	..... 34.95
'74 – '75	Black jacket..... D4DZ-2078ASS-BK.....ea	..... 34.95
	Clear jacket..... D4DZ-2078ASS-CL.....ea	..... 34.95

**Front Disc**

'74 – '77	Black jacket..... D6AZ-2078ASS-BK.....ea	..... 32.95
	Clear jacket..... D6AZ-2078ASS-CL.....ea	..... 32.95



**BRAKE HOSE CLIP SET**

Set of 3.

'70 – '77	..... BHC101.....set.....	..... 5.95
-----------	---------------------------	------------



**WHEEL CYLINDERS**

**Front**

'70	1 1/16" bore.	
	LH..... WC36100.....ea	..... 19.95
	RH..... WC36101.....ea	..... 19.95
'71	Maverick 170, 200, 250, 302; Comet 6-cylinder except 250.	
	1 1/8" bore.	
	LH.	
	..... WC37177.....ea	..... 29.95
	RH.	
	..... WC37178.....ea	..... 29.95
'71	Comet 250, 302.	
	1 1/8" bore.	
	LH.	
	..... WC36017.....ea	..... 19.95
	RH.	
	..... WC36018.....ea	..... 19.95

**WHEEL CYLINDERS CONTINUED**

**Front Continued**

'72	6-cylinder except 250.	
	1 1/8" bore.	
	LH.	
	..... WC37177.....ea	..... 29.95
	RH.	
	..... WC37178.....ea	..... 29.95
'72	250, 302.	
	1 1/8" bore.	
	LH.	
	..... WC36017.....ea	..... 19.95
	RH.	
	..... WC36018.....ea	..... 19.95
'73 – '75	1 1/8" bore.	
	LH.	
	..... WC36017.....ea	..... 19.95
	RH.	
	..... WC36018.....ea	..... 19.95



**WC37108**



**134.61032**



**134.61033**



**WC17507**



**WC17508**

**Rear**

'70	27/32" bore.	
	LH or RH..... WC37108.....ea	..... 19.95
'71	170, 200.	
	27/32" bore.	
	LH or RH..... WC37108.....ea	..... 19.95
'71 – '73	250, 302.	
	27/32" bore.	
	LH..... 134.61032.....ea	..... 29.95
	RH..... 134.61033.....ea	..... 29.95
'72	27/32" bore.	
	LH or RH..... WC37108.....ea	..... 19.95
'74 – '75	7/8" bore.	
	LH.	
	..... WC17507.....ea	..... 19.95
	RH.	
	..... WC17508.....ea	..... 19.95



**BD1634**



**BD2641**



**BD2623**

**BRAKE DRUMS**

**Front**

'70 – '73	6-cylinder.	
	9". 4 lug holes..... BD2642.....ea	..... 39.95
'70 – '73	All with finned drum, full cast drum.	
	10" x 2 1/4" or 10" x 2 1/2". 5 lug holes.	
	..... BD1634.....ea	..... 55.00

**Rear**

'70 – '73	9" x 1 1/2". 2.434" center hole. 4 lug holes.	
	..... BD2641.....ea	..... 39.95
	10" x 1 3/4". 2.434" center hole. 5 lug holes.	
	..... BD2623.....ea	..... 44.95



**NEW BRAKE SHOES**

Requires 1 set per vehicle.

**NOTE:** Please be sure of your brake size before placing your order.

**Front**

For Brake Self-adjuster Repair Kits, see part #QA2514 and #QA2515 below.

'71	250, 8-cylinder with 10" x 2 1/4".	
	QA154.....set.....	39.95
'72	250, 302 with 10" x 2 1/2".	
	QA169.....set.....	34.95
'73 - '75	10" x 2 1/2".	
	QA169.....set.....	34.95

**Rear**

'71	10" x 1 3/4".....	QA151.....set.....	29.95
'73 - '77	10" x 1 3/4".....	QA151.....set.....	29.95

**REMANUFACTURED BRAKE SHOES**

**Front**

'70 - '72	'70 - '72 Maverick with 9" x 2 1/4"; '71 - '72 Maverick / Comet 6-cylinder (except 250) with 9" x 2 1/4".	
	QA243.....set.....	29.95

**Rear**

'70 - '72	'70 all; '71 - '72 6-cylinder (except 250) with 9" x 2 1/4".	
	QA244.....set.....	29.95



**BRAKE DRUM HARDWARE KIT**

Includes springs and hold-down kit.

'71	Comet front with 10" x 2 1/4" brakes and rear with 10" x 2" shoes. Requires 2 per vehicle.	
	H7045.....kit.....	19.95



**BRAKE SELF-ADJUSTER REPAIR KITS**

Each kit includes screw assembly, lever spring, cable, and rubber plug. Each kit does 1 wheel.

'70 - '77 with 10" shoes. Front or rear.	
LH.	
QA2514.....kit.....	16.95
RH.	
QA2515.....kit.....	15.95



**DRUM BRAKE ADJUSTMENT HOLE COVERS**

Oval plugs. 5/16" x 1". Set of 4.  
'70 - '72 front drums; '70 - '77 rear drums.

AK108.....set.....	3.00
--------------------	------



**REAR DRUM BRAKE PLATE MOUNTING BOLTS**

Holds the backing plate to the rear axle housing. Set of 4 bolts. Requires 2 sets per vehicle. 3/8" - 24 x 1 3/16" bolt, .62" x 1.0" head.

With 8" or 9" rear end.	
375748S.....set.....	5.95



**DISC BRAKE ROTOR**

**NOTE:** Due to weight, there is a \$15.00 per order shipping charge for this item.

'74 - '77	D6042.....ea.....	59.95
-----------	-------------------	-------

184070



184069

**REMANUFACTURED DISC BRAKE CALIPERS**

All units sold on an exchange basis only. Call for information.

'74 - '77	LH.	
	184070.....ea.....	29.95
	RH.	
	184069.....ea.....	29.95
	Core fee for either.....ea.....	25.00



**FRONT DISC BRAKE PADS**

'74 - '77	D91.....set.....	27.95
-----------	------------------	-------



639540

**BRAKE SPEED BLEEDERS**

Replaces the original bleeder screw to make bleeding brakes a one-person task. Uses OEM-style sealing area to guarantee a positive leak-proof seal.

'70 - '75	Front and rear brake drums.	
	1/4" - 28 thread x 1" long.	
	639540.....pr.....	17.95
'70 - '77	'70 - '75 Maverick front disc brakes, front / rear drum brakes; '76 - '77 Maverick front disc brakes, rear drum brakes.	
	3/8" - 24 thread x 1" long.	
	639590.....pr.....	16.95



A-6



A-13



A-12

**WHEEL BEARINGS AND RACE ASSEMBLIES**

**Front - Inner**

'70	Before 8/25/69.....	A-6.....ea.....	12.95
'70 - '77	After 8/25/69.		
	.....	A-13.....ea.....	13.95

**Front - Outer**

'70	Before 8/25/69.....	A-2.....ea.....	12.95
'70 - '77	After 8/25/69.		
	.....	A-12.....ea.....	12.95

**Rear - Outer**

'70 - '77 with 7.75", 8", 9" (28 spline) or 9" (31 spline) ring gear. Requires 2 per vehicle.		
.....	RW207CCRA.....ea.....	27.50



**INNER WHEEL BEARING SEAL**

'70 - '77	.....	6815.....ea.....	4.95
-----------	-------	------------------	------



**REAR WHEEL SEAL (AXLE SEAL)**

'70 - '77 with 7.75", 8", 9" (28 spline) or 9" (31 spline) ring gear. Requires 2 per vehicle.		
.....	9569S.....ea.....	11.95



Boxing Fee



Oversize



Truck Freight



**WHEEL BEARING DUST CAPS**

Prevents mud, dust, and dirt from reaching the wheel bearings.

**Zinc Plated**

- '70 - '77 With 1<sup>9</sup>/<sub>16</sub>" (39.7 mm) I.D. wheel hubs.
  - ..... 13976 ..... ea ..... 3.95
  - With 1<sup>25</sup>/<sub>32</sub>" (45.25 mm) I.D. wheel hubs.
    - ..... 13975 ..... ea ..... 4.50



**Chrome Plated**

1.790" in diameter. Heavy-duty chrome plating.  
..... 2485 ..... pr ..... 9.95



**FRONT SPINDLE LOCK NUT KIT**

This universal kit includes (1) 3/4" - 16 nut; (1) washer; (1) retainer; (1) cotter pin. This kit will work with most of the applications above but check your spindle thread size before ordering.

- '70 Maverick before 8/24/69.
  - ..... 04990 ..... kit ..... 7.95

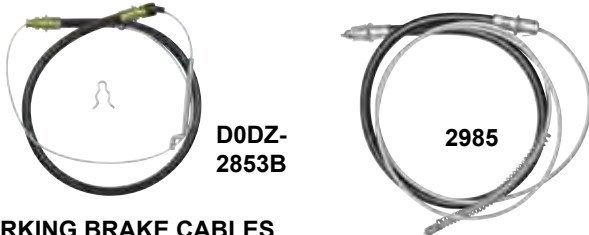

**PARKING BRAKE CABLES**

Made in the USA.

**Front**

- '70 - '72 All. Overall inner cable length: 50.75".
  - ..... D0DZ-2853B ..... ea ..... 59.95
- '73 - '74 All. Overall inner cable length: 52.75", outer housing mounting length: 24.625".
  - ..... D3DZ-2853A ..... ea ..... 59.95
- '75 Maverick. Overall inner cable length: 46.9375".
  - ..... D5DZ-2853A ..... ea ..... 59.95
- '76 - '77 All. Overall inner cable length: 58.375".
  - ..... D6DZ-2853B ..... ea ..... 59.95

**Rear**

- '70 LH or RH. Overall length of wire and fittings: 69", outer housing mounting length: 23.75".
  - ..... D0DZ-2A635A ..... ea ..... 39.95
- '71 - '74 '71 - '74 with drum brakes; '74 with front disc brakes. LH. Inner cable length: 75.5", outer housing length: 25".
  - ..... 2985 ..... ea ..... 34.95
- RH. Inner cable length: 62.38", outer housing length: 25".
  - ..... 2984 ..... ea ..... 34.95
- '75 - '77 LH. Inner cable length: 58.75", outer housing length: 25.94".
  - ..... D7DZ-2A635D ..... ea ..... 39.95
- RH. Inner cable length: 33.25", outer housing length: 25.44".
  - ..... D7DZ-2A635C ..... ea ..... 39.95



**PARKING BRAKE CABLE RETAINER SET**

Holds the cable to the bracket, crossmember, etc. Set of 3 clips. Not all applications use all the clips.

- '70 - '77 ..... AK1030 ..... set ..... 4.95



**PARKING BRAKE CABLE CONNECTOR**

'70 - '74 Maverick; '72 Comet.
 

- ..... C6OZ-2A790A ..... ea ..... 9.95



**C7ZZ-2A808A**



**ST2A816**

**PARKING BRAKE REAR CABLE IDLER**

'70 - '74 ..... C7ZZ-2A808A ..... ea ..... 11.95

**PARKING BRAKE REAR CABLE IDLER BRACKET**

Welds to the front floor pan.
 

- '70 - '74 ..... ST2A816 ..... ea ..... 9.95

Typical Parking Brake Cable Assembly

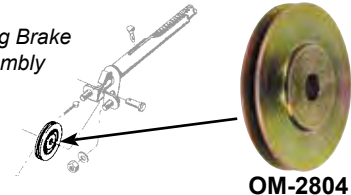

**OM-2804**

**PARKING BRAKE CABLE PULLEY**

'71 - '75 Maverick; '71 - '72 Comet.
 

- ..... OM-2804 ..... ea ..... 19.95



**PARKING BRAKE CABLE EQUALIZER ROD**

7 1/2" long. Includes 2 nuts.
 

- '71 - '77 ..... B7A-2628B ..... ea ..... 15.95



**C1DD-2A642R**



**D1OZ-2A642R**



**D1OZ-2A642SET**

**PARKING BRAKE LEVER LINKS**

This is the link between the parking brake lever and the primary brake shoe. 6" long.

- '70 - '72 6-cylinder with 9" rear drum brakes. Requires 2 per vehicle.
  - ..... C1DD-2A642R ..... ea ..... 7.95
- '71 - '75 250 / 302 with 10" rear drum brakes. Requires 2 per vehicle. Link only.
  - ..... D1OZ-2A642R ..... ea ..... 9.95
- Link and spring.
  - ..... D1OZ-2A642SET ..... ea ..... 14.95



**C8SZ-2454B**



**C8SZ-2A798A**

**PARKING BRAKE PEDAL PAD AND TRIM**

**Pad**

'75 ..... C8SZ-2454B ..... ea ..... 6.95

**Trim**

'75 ..... C8SZ-2A798A ..... ea ..... 9.95



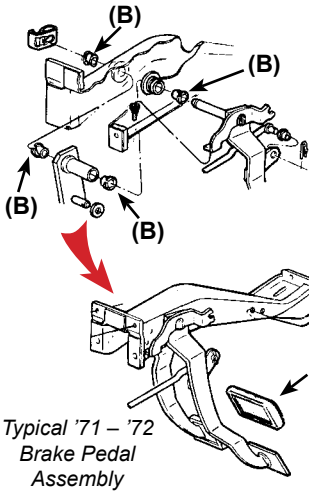

Typical '71 - '72 Brake Pedal Assembly



**BRAKE PEDAL PADS AND TRIM (A)**

**Pads**

'70	M/T	..... C5ZZ-2457G	..... ea	..... 3.95
'71	Maverick; Comet with drum brakes.			
	M/T.			
		..... C5ZZ-2457G	..... ea	..... 3.95
	A/T.			
		..... C6OZ-2457A	..... ea	..... 6.95
'72	M/T.			
		..... C5ZZ-2457G	..... ea	..... 3.95
	A/T after 4/3/72.			
		..... C6OZ-2457A	..... ea	..... 6.95
'73 - '75	With drum brakes.			
	M/T	..... C5ZZ-2457G	..... ea	..... 3.95
	A/T	..... C6OZ-2457A	..... ea	..... 6.95
'74 - '75	With disc brakes before 12/16/74.			
	M/T	..... C5ZZ-2454D	..... ea	..... 9.95
	A/T	..... D3ZZ-2454A	..... ea	..... 9.95
'75	With disc brakes after 12/16/74.			
	M/T	..... C5ZZ-2457G	..... ea	..... 3.95
	A/T	..... C6OZ-2457A	..... ea	..... 6.95
'76 - '77	M/T	..... C5ZZ-2457G	..... ea	..... 3.95
	A/T	..... C6OZ-2457A	..... ea	..... 6.95



**D1ZZ-2A487B**

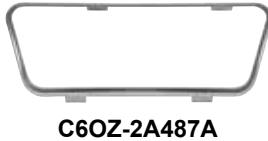

**C6OZ-2A487A**

**Pad Trim**

'72 - '77	M/T	..... D1ZZ-2A487B	..... ea	..... 14.95
	A/T after 4/3/72	..... C6OZ-2A487A	..... ea	..... 13.95



**BRAKE PEDAL PAD AND TRIM**

Includes brake pedal pad with "DISC BRAKE" emblem in the middle and outer trim piece.

For individual parts, see #s D3ZZ-2454A and C6OZ-2A487A above.

'74 - '75	A/T with disc brake before 12/16/74.			
		..... D3ZZ-2454/2A487A	..... ea	..... 19.95



**BRAKE PEDAL ARM MOUNT BRACKET BUSHING (B)**

Requires 2 per arm.

'70 - '77				
	..... B7AZ-2471B	..... ea	..... 1.95	



**BRAKE / CLUTCH PEDAL SUPPORT REPAIR KIT**

Kit includes 2 plastic bushings, 2 roller bearings, 2 metal sleeves, 1 shaft, 1 cotter pin, 2 crush washers, 1 flat washer, 2 snap rings, and 2 washers.

'70 - '73	Maverick; '71 - '73 Comet. All with M/T and roller bearings.			
	..... C5ZZ-2478RBMK	..... kit	..... 61.95	

**BRAKE LAMP (STOP LAMP) SWITCH AND RETAINER PIN**



**Switch**

'70 - '77				
	..... SW881	..... ea	..... 15.95	



**Switch Retainer Pin**

Attaches the switch to the master cylinder.

'70 - '72				
	..... 380699-S100	..... ea	..... 3.25	



**REAR DRUM BRAKE 11" UPGRADE KIT**

Convert your small rear drum brakes to big 11" brakes with heavy-duty finned drums. Fully assembled and ready to bolt on. Features high-performance ceramic brake shoes and high-volume wheel cylinders pre-assembled on new backing plates. Limited 1-year manufacturer's warranty.

With drum brakes and 8" or 9" Ford small bearing (3 3/8" x 2") rear end ..... DR1504K ..... kit ..... 579.00



**FRONT DRUM-TO-DISC BRAKE CONVERSION KIT**

Convert your front drum brakes to disc brakes. This front manual disc brake kit bolts to your original spindles.

Kit includes:

- 1" bore dual-reservoir master cylinder
- OE-style cast-iron 4-piston calipers
- pads
- 11 1/4" rotors
- proportioning valve kit
- dust caps
- caliper brackets
- rubber hoses
- bearings and seals
- hardware

**NOTE:** 14" or larger disc brake wheels required. Not all 14" wheels will fit this application. Wheel fitment is customer's responsibility.

Limited 1-year manufacturer's warranty.

**NOTE:** This is an oversized item; additional shipping charges apply.

'71 - '77		..... DB7177MAV	..... kit	..... 899.00
-----------	--	-----------------	-----------	--------------



**REAR DRUM-TO-DISC BRAKE CONVERSION KITS**

Includes single-piston cast-iron calipers with built-in parking brake and 10.5" x .9375" rotors.

**NOTE:** These are oversized items; additional shipping charges apply.

**A110-2**  
8" or 9" 28-spline rear end with small bearing. Minimum 14" wheel.

..... A111-2 ..... kit ..... 729.00  
9" 31-spline rear end with large bearing. Minimum 14" wheel.

..... A110-2 ..... kit ..... 729.00

**NOTE:** The A111-2 is to be used with all 14" wheels including the Styled Steel and Magnum 500s.

**BF** Boxing Fee      **OS** Oversize      **TF** Truck Freight



**TAILLIGHT, TRUNK, INTERIOR LAMP WIRE LOOM CLIP**

Fits various Ford and Mercury vehicles. Black plastic clip that fastens onto sheet metal and hooks around wire.

..... 643558 ..... ea ..... 1.30



**UNIVERSAL TAPE-ON WIRE LOOM ANCHOR CLIP**

Fits all Ford and Mercury vehicles. Tapes onto the wire loom and then fastens to sheet metal (fender apron, etc.)

..... 642553 ..... ea ..... 1.50



**AV14874**



**AV2769**

**SPIN LOCK NUTS**

1/4" - 20.

Standard flange (19/32" O.D.) ..... AV14874 ..... ea ..... .25

Large flange (11/16" O.D.) ..... AV2769 ..... ea ..... .30

**Interior Hardware**



**270442**

**INTERIOR SCREW KITS**

Kit consists of all the screws that are visible inside the passenger compartment.

Kits usually contain screws for the following: coat hooks, sunvisors, dash bezel, dash panel, radio bezel, door weatherstrip, quarter seals, kick panels, pillar moulding, radio speaker, quarter

panels, step plates, seat side, and steering column cover. May contain more screws than needed.

'70 - '72 2-door.  
46 pieces ..... FO1600 ..... kit ..... 15.95

'74 - '75 2-door.  
42 pieces.  
 ..... 270442 ..... kit ..... 15.95

'74 - '75 4-door.  
63 pieces ..... FO1786 ..... kit ..... 24.95

**SEAT BELT MOUNTING HARDWARE**



**382626-S**



**382627S**



**384966-S**



*Head Detail*

**Torx-Head Bolts**

Yellow zinc plated. May be correct for some factory applications. Can also be used when adding aftermarket belts if you want the Torx-style bolt. Verify measurements before ordering. Made in the USA.



**Shoulder Harness Bolt**

3/8" - 16 threads, 1 1/2" long with .23" long shoulder.

..... 382626-S ..... ea ..... 6.95

**Seat Belt Bolt**

7/16" - 20 threads, 1 3/4" long with 1/2" long shoulder.

..... 382627S ..... ea ..... 8.95

**Rear Seat Belt Bolt Set**

7/16" - 20 threads, 1 3/4" long, full threads with lead point. Set of 4.

..... 384966-S ..... set ..... 6.00

**SEAT BELT MOUNTING HARDWARE CONTINUED**

**Hardware Kits - Grade 5**



**Lap Belt Kit**

Includes (2) grade-5 bolts, (2) grade-5 nuts, (2) flat washers, and (2) lock washers. 7/16" - 20 threads.

..... AK199 ..... kit ..... 2.50

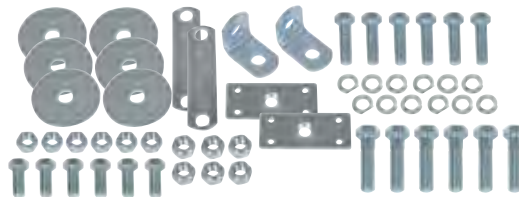

**Shoulder Harness Kit**

Includes (12) nuts, (18) grade-5 bolts, (12) lock washers, (6) flat washers, anchors, and L-brackets to install 2 lap and shoulder belts. All hardware is zinc coated for an attractive finish.

**NOTE:** Not for off-road or racetrack applications.

..... AK200 ..... kit ..... 39.95



**C6AZ-6224146B**



**AK236**



**AK273**

**ARM REST CLIP AND SCREWS**

**Clip**

'70 - '77 '70 - '72 Maverick; '73 - '77 Maverick without molded arm rest;

'71 - '72 Comet without molded arm rest.

..... C6AZ-6224146B ..... ea ..... 3.50

**Screws**

Set of 2.

'70 - '77 Hex washer head.

..... AK236 ..... pr ..... 1.00

Phillips pan head.

..... AK273 ..... pr ..... 1.00



**STEP PLATE SCREWS**

Phillips oval head. 3/4" long. Set of 12.

'70 - '77 2-door. '70 requires 8, '71 - '77 requires 12.

..... AK120 ..... set ..... 2.75



**DOOR LATCH SCREWS**

Set of 3 screws.

'70 - '72 ..... AK400 ..... set ..... 2.50



**DOOR HINGE PIN**

'70 - '77 Requires 1 per hinge. Requires trimming.

..... AV14559 ..... ea ..... 1.95



**DOOR HINGE PIN BUSHING**

'70 - '77 requires 2 per hinge.

..... AV14550 ..... ea ..... 1.25



**DOOR LOCK CYLINDER RETAINER**

'70 - '77 Maverick; '71 - '72 Comet.  
 ⚙️ ..... C5AZ-6222023A .....ea ..... 2.00



**AK560**

**DOOR STRIKER PLATE SCREWS**

Set of 4.  
 '70 - '77 Zinc plated.  
 ⚙️ ..... AK560 .....set ..... 3.00  
 Stainless steel.  
 ⚙️ ..... AK562 .....set ..... 3.00



**D3DZ-6252136A**

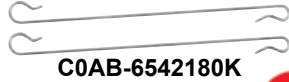

**C0AB-6542180K**



**HEADLINER RETAINERS**

**Front Retainers**

Small plastic retainers at the tops of the windshield posts. Black.  
 '70 - '77 ..... D3DZ-6252136A .....pr ..... 11.95

**Rear Rod Retainers**

Holds the rear headliner rod in place, attaches to the roof. 4" long.  
 ..... C0AB-6542180K .....pr ..... 3.95



**COAT HOOK SCREW**

'70 - '77 ⚙️ ..... AV2713 .....ea ..... 25



**C9OZ-9760A**



**C5AZ-9C804B**



**C8OZ-9873A**

**ACCELERATOR PEDAL HARDWARE**

**Pivot Springs**

'70 - '71 '70 Maverick 6-cylinder before 6/16/69; '71 Comet all.  
 ⚙️ ..... C9OZ-9760A .....ea ..... 5.95  
 '71 - '72 All.  
 ⚙️ ..... C5AZ-9C804B .....ea ..... 3.50

**Pin**

'70 - '71 '70 Maverick 6-cylinder; '71 Comet all.  
 ⚙️ ..... C8OZ-9873A .....ea ..... 4.95



**FIREWALL INSULATION RETAINER**

Rubber. 1 1/8" long, 1" diameter head.  
 '70 - '72  
 ⚙️ ..... C8ZZ-6501691A .....ea ..... 1.95



**HEATER BOX CLIP**

Holds the heater box that houses the heater core. Quantity varies by vehicle.  
 '70 - '77 Maverick; '71 - '72 Comet.  
 ⚙️ ..... C0DF-19A779A .....ea ..... 2.95



**STEERING WHEEL MOUNTING NUT**

Correct-style lock nut for mounting the wheel to the column shaft. 5/8" - 18. 1 5/16" hex. Grade 5, cadmium plated.  
 '70 - '77  
 ⚙️ ..... 382412-S .....ea ..... 4.95

**Trunk / Exterior Hardware**



**TRUNK LID MOUNTING BOLT**

Fits multiple applications. 1/2" hex head, 5/16" - 18 threads, 1 5/16" long. Black phosphate with a dog point and 7/8" diameter SEMS washer.



**NOTE:** Please verify that the threads and length of your original bolt match before ordering. .... 57039-S2 .....ea ..... .50



**SPARE TIRE MOUNTING NUT**

'70 - '77 ⚙️ ..... C8AZ-1462B .....ea ..... 4.95



**WINDSHIELD WIPER ARM CLIP**

Reproduction.  
 '70 - '77 ⚙️ ..... C5ZZ-17531A .....ea ..... 2.95



**HEADLAMP BULB RETAINING RING SCREWS**

These stainless steel screws hold the headlight bulb retaining ring to the adjusting bucket. Set of (6) #8 - 18 x 7/16" Phillips head screws (replaces Ford part number 375452-S).



'70 ..... AK294 .....set ..... 3.75



**C6AZ-13031R**



**D5UZ-13031A**

**HEADLAMP SPRINGS**

'70 ..... C6AZ-13031R .....ea ..... 2.95  
 '75 - '77 Genuine Ford.  
 ⚙️ ..... D5UZ-13031A .....ea ..... 8.95



**HEADLAMP ADJUST KIT**

Includes 2 adjusting screws and nuts, 4 attaching screws, and 1 spring. Enough to do 1 headlamp.

'70 - '74 Maverick; '73 - '74 Comet.  
 ⚙️ ..... AK413 .....kit ..... 8.95

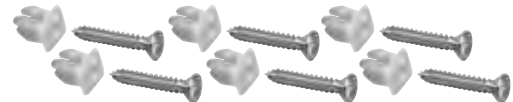

**HEADLAMP DOOR MOUNTING KIT**

Includes 6 stainless steel screws and 6 nylon nuts.  
 '70 - '77 ⚙️ ..... AK1014 .....kit ..... 4.00



**MARKER LAMP HOUSING MOUNTING STUDS**

'70 - '77 Maverick; '71 - '77 Comet.  
 ⚙️ ..... D0ZZ-15201S .....pr ..... 2.50



**EXTERIOR SCREW KITS**

Kits include screws for headlamp moulding, exterior (side-view) mirror, license plate lamp mounting, and license plate lamp lens.

- '75 11 pieces..... FO1785.....kit..... 4.95
- '75 Also includes screws for wheelhouse moulding.  
39 pieces..... FO1785A.....kit..... 12.95



**BODY BOLTS**

- '70 5/16" - 18 x 1". Has "LF" stamped on top. Requires 12.  
..... AV9756 .....ea ..... 40
- 5/16" - 18 x 1 5/16". With flat washer. Has flag stamped on top.  
Zinc plated ..... 57140-S8 .....ea ..... 1.50



**FENDER BOLTS**

- '70 - '77 Requires 12.  
5/16" - 18 x 1 5/16". With star washer. Has "HTS" logo on top.  
Cadmium ..... AK433C .....ea ..... 1.50
- '70 - '77 Requires 12.  
5/16" - 18 x 1". With star washer. Has "01IG" stamped on top. Black ..... AK341B .....ea ..... 1.00
- '70 - '77 7/8". With flat washer. Has flag stamped on top. Zinc plated.  
..... 57140-S8 .....ea ..... 1.50
- '70 - '77 1/4" - 20 x 7/8". With disc washer (washer O.D.: 3/4"). 7/16" hex). Has "LF" stamped on top. Parkerized.  
Use with U-nut #AV10050 or #AV10051 below.  
..... AV10823 .....ea ..... 50



**FENDER MOUNT U-NUTS**

- '70 - '77 1/4" - 24.  
1 7/32" center of hole to edge. Use with body bolt #AV10823 (see above)..... AV10050 .....ea ..... 50
- 2 5/32" center of hole to edge. Use with body bolt #AV10823 (see above)..... AV10051 .....ea ..... 60
- '70 - '77 5/16" - 18. Long reach.  
Requires approximately 10 per vehicle.  
..... AV8814 .....ea ..... 50
- Set of 12..... AK119 .....set..... 5.00



**CAGE NUTS**

- Used to attach the bottom of the front fender to the cowl.
- 1/4" - 20 threads. Fits 5/16" square hole (panel range: 0.025" - 0.063").  
..... AK3144 .....ea ..... 1.25
  - 5/16" - 18 threads. Fits 1/2" square hole (panel range: 0.025" - 0.063").  
..... 356833-S2 .....ea ..... 1.25
  - 3/8" - 16 threads. Fits 1/2" square hole (panel range: 0.093" - 0.126").  
..... 382329-S2 .....ea ..... 1.25



**TUBE NUTS (BARREL CLIPS)**

Used to attach to your vehicle emblems that have pins on the back. They are not necessary for self-adhesive emblems.

- Small Fits 1/16" stud, 1/8" panel hole.  
..... 378362S .....ea ..... 50
- Medium Fits 1/8" stud, 3/16" panel hole.  
..... AV11293 .....ea ..... 50
- Large Fits 3/16" stud, 1/4" panel hole.  
..... AV8405 .....ea ..... 1.00



**BUMPER BOLT KITS**

Each kit does both front and rear bumpers.

- '70 - '71 20 pieces..... FO193.....kit..... 22.95
- '74 - '77 40 pieces..... FO196.....kit..... 32.95



**HOOD Moulding SCREWS**

Zinc plated. 6 pieces.

- '70 - '77 Maverick..... AK2001.....set..... 1.50

'73 - '77 Windshield

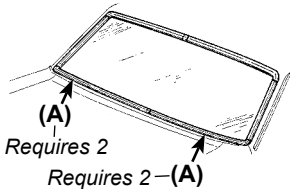

'73 - '77 4-door Back Glass

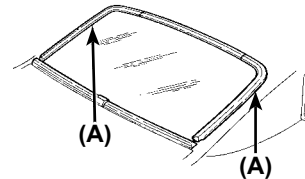

**WINDSHIELD AND BACK GLASS Moulding RETAINERS**

- '70 - '77 '73 - '77 windshield moulding requires 4 (2- or 4-door); '73 - '77 back glass moulding requires 2 (4-door only).  
Brown.  
(A)..... D1AZ-6542413B .....ea ..... 30
- Set of 12..... AK247 .....set..... 3.00
- '73 - '77 Blue..... D0DZ-6203174A.....ea ..... 40



**WINDSHIELD Moulding REMOVAL TOOL**

Can be used on most Ford vehicles. Metal ends with plastic grip in the middle. .... 2107 .....ea ..... 11.95



**UNIVERSAL ROCKER PANEL MOULDING CLIPS**

3/4" x 3 3/16" plate, 1/2" stud. Butterfly style. Includes nut and rubber washer.

..... 3164 ..... ea ..... 2.50  
Set of 12 ..... 3164SET ..... set ..... 26.95

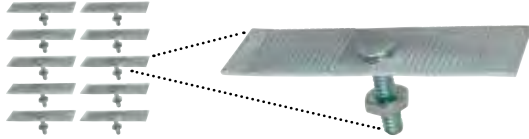

AK1008

**UNIVERSAL BODY MOULDING CLIP SET**

Snaps off to fit almost any body moulding. 24 x 3/4" stud. Package of 10.

..... AK1008 ..... pkg ..... 9.95



**UNIVERSAL MOULDING CLIP - NYLON**

Nylon clip with a push-pin for a 5/16" hole. The clip can be snapped off at 5/32" perforations to fit the moulding. The clip plate is 3" long and 3/4" wide. On some mouldings the clip may need to be installed in the moulding and then pushed onto the vehicle.

..... AK8581 ..... ea ..... 2.00

AK2818

AK19626

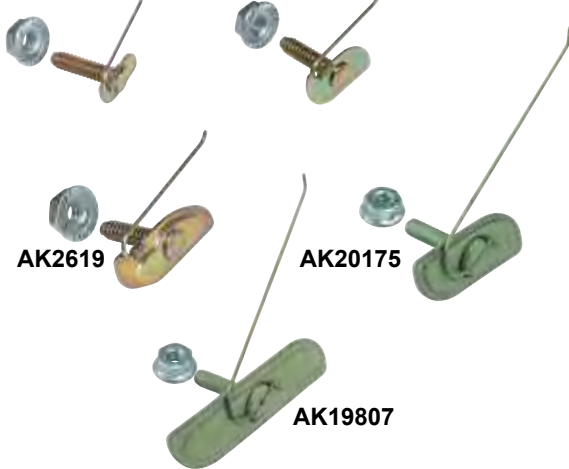

AK2619

AK20175

AK19807

**UNIVERSAL MOULDING CLIPS AND NUTS**

Thread size: 10 - 24.

3/8" x 1 3/16" plate, 5/8" long stud..... AK2818 ..... ea ..... 1.50  
1/2" x 1 1/16" plate, 3/4" long stud ..... AK19626 ..... ea ..... 1.50  
9/16" x 1 1/2" plate, 3/4" long stud ..... AK2619 ..... ea ..... 1.50  
1 1/16" x 1 5/8" plate, 3/4" long stud... AK20175 ..... ea ..... 2.00  
1 1/16" x 2 17/32" plate, 3/4" long stud. AK19807 ..... ea ..... 2.00



**WHEELHOUSE MOULDING SCREW KIT**

Requires 1 kit per wheelhouse, 4 kits per vehicle. 8 pieces.

'70 - '77 With wheelhouse moulding.  
..... AK588 ..... kit ..... 1.75



**STUD FOR WINDSHIELD AND TRIM MOULDING CLIPS**

This zinc-plated steel screw-in stud is to replace broken weld-on studs used for attaching moulding clips to body. Short length for shallow areas with Phillips flat head.

With weld-on studs for windshield or trim moulding clips.

..... AK1017 ..... ea ..... .50

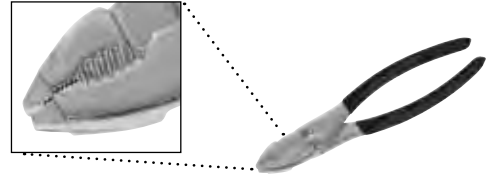

**MOULDING CLIP INSTALLATION PLIERS**

Zinc-plated pliers made to install flare-type moulding clips. The tips are designed to take hold and crimp the outer center tabs of the clip. Features rubber grip handles. .... TL300 ..... ea ..... 14.95



AV14231



D6AZ-1107A

**WHEEL STUD BOLTS**

1/2" - 20 x 1 9/16".

'70 - '77 Grade 8. Press-in.  
..... AV14231 ..... ea ..... 1.95  
'76 Rear ..... D6AZ-1107A ..... ea ..... 1.00

**Engine Hardware**

**UNDERHOOD AND TRUNK HARDWARE KIT**

Includes all the bolts, nuts, u-nuts and screws under the hood and in the trunk, such as fender bolts and battery tray bolts and nuts, not including engine and A-frame hardware. This kit is specific to '74 - '75, but most items will work on other years. 190 pieces.

'74 - '75 ..... FO275 ..... kit ..... 109.95



Typical Kit

**COMPLETE ENGINE HARDWARE KIT**



Exact OE fasteners manufactured in the USA. All fasteners are of the correct grade and finish as specified by all Ford engineers. All original manufacturer markings and design details.

This 90-piece kit includes fasteners to attach air cleaner, air cleaner heat shroud, air cleaner snorkel, carburetor, carburetor spacer, crank pulley, harmonic balancer, distributor, distributor points, distributor vacuum unit, engine block drain plugs, engine fan spacer (1.91"), exhaust manifold (with Ramp-Loks), fuel pump, oil pan, starter, timing chain cover, valve cover, thermostat housing (water neck), and water pump.

'70 - '73 250 ..... C9DE-342 ..... kit ..... 82.50



Typical Kit

**AIR CONDITIONING FASTENER KIT**



This 18-piece kit includes fasteners to attach the compressor, compressor braces (side and rear), compressor bracket, compressor clutch, and compressor field coil.

'70 - '73 200 / 250.  
..... D0ZA-AC200/250 ..... kit ..... 24.95



**AK301**



**HC209**



**BPA-18572**

**RADIATOR HOSE CLAMPS**

Wire-type hose clamps.

1 3/4" .....	AK300 .....	ea .....	8.00
2" .....	AK301 .....	ea .....	8.95

**HEATER HOSE CLAMPS**

**Original-Style Tower Clamp**

'70 - '77		HC209 .....	ea .....	2.95
-----------	--	-------------	----------	------

**Bolt-Type Spring Clamp**

'70 - '77	With 5/8" heater hose.		BPA-18572 .....	ea .....	2.00
-----------	------------------------	--	-----------------	----------	------



**STAINLESS STEEL ENGINE HOSE CLAMP KIT**

A great way to finish your engine dress-up project. The clamps have the FoMoCo logo stamping (except for 5/16" - 3/8" size) and feature a worm gear design for tightening. They are also sized correctly so there is no excessive "tail" overhang. Kit includes: (2) lower radiator - 2 1/8"; (2) upper radiator - 2"; (6) heater and bypass - 5/8"; (6) fuel line and sending unit - 5/16" - 3/8" (not stamped FoMoCo).

Fits most 260 / 289 / 302.	.....	8287-SBFK .....	kit .....	29.95
----------------------------	-------	-----------------	-----------	-------



**DISTRIBUTOR HOLD-DOWN CLAMP**

Chrome. Includes installation bolt.

V6, V8 except FE.

.....	M12270A302 .....	ea .....	10.95
-------	------------------	----------	-------



**ALTERNATOR PULLEY NUT AND WASHER**

Gold zinc.



'70 - '77		.....	C7AL-644 .....	ea .....	2.95
-----------	--	-------	----------------	----------	------



**CP5185**



**MG5185**



**RC4300**

**ALTERNATOR BRACKET SETS**

Includes adjustment arm and top bracket.

Includes adjustment arm and top bracket.

'70 - '77	Black.		.....	CP5185 .....	set .....	22.95
	Chrome.		.....	MG5185 .....	set .....	24.95

'70 - '77

302. Adjustable. Made of high-quality, lightweight, T-6061 billet aluminum with a polished finish. Kit includes: mount brackets, adjustable rod, mounting bolts, and spacers.

**NOTE:** Professional installer is highly recommended; no instructions are included.



.....	RC4300 .....	kit .....	46.95
-------	--------------	-----------	-------



**C5AZ-10718A**



**B10718BL**

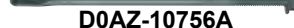

**D0AZ-10756A**

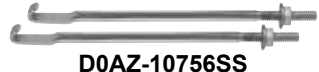

**D0AZ-10756SS**

**BATTERY HOLD-DOWN HARDWARE**

**Clamps**

'70 - '77		.....	C5AZ-10718A .....	ea .....	8.95	
	Billet aluminum.		.....	B10718BL .....	ea .....	40.95

**J-bolts**

'70 - '72	Requires 2.		.....	D0AZ-10756A .....	ea .....	2.50
	Stainless steel.		.....	D0AZ-10756SS .....	pr .....	16.95

**STARTER SOLENOID AND VOLTAGE REGULATOR MOUNTING SCREWS**



Set of 4 .....	AK266 .....	set .....	1.00
----------------	-------------	-----------	------



**376914S**

**WIRING STRAPS**

'70 - '77		.....	376914S .....	ea .....	.70	
	Set of 20.		.....	AK114B .....	set .....	8.00

**SOLDERLESS WIRE TERMINAL / CONNECTOR KIT**



Contains an assortment of the 18 most popular solderless, insulated terminals and connectors. Comes in a plastic display box with dividers. Includes 9" crimping tool. 175 pieces.....

.....	TK50413A .....	kit .....	19.95
-------	----------------	-----------	-------



**358871-S8**



**4210**



**4209**



**M9697A**



**AK241**

**AIR CLEANER WING NUTS AND THUMBSCREW**

**Wing Nut - Reproduction**

Has the same locking notch as OEM. Show-car quality.

'70 - '77	Fits almost everything except some 6-cylinders engines.		.....	358871-S8 .....	ea .....	2.25
-----------	---	--	-------	-----------------	----------	------

**Wing Nuts - Aftermarket**

**Spectre**

Will fit any 1/4" - 20 thread studs. This triple-chrome plated tri-corner design wing nut features a black wrinkle finish in the center.

Small		.....	4210 .....	ea .....	4.95
Large		.....	4209 .....	ea .....	6.95

**Ford Oval**

Chrome oval with dark blue center. Will fit 1/4" - 20 thread stud.

.....	M9697A .....	ea .....	15.95
-------	--------------	----------	-------

**Thumbscrew**

'70 - '77	6-cylinder.		.....	AK241 .....	ea .....	3.75
-----------	-------------	--	-------	-------------	----------	------



**FUEL SENDER LOCKING RING**

'70 - '77 ..... COAZ-9A307B ..... ea ..... 5.95



**FAN SPACER BOLT KIT**

Kit includes (4) 5/16" - 24 x 3 1/4" bolts and (4) lock washers.  
With 2 3/4" fan spacer.

..... AK1040 ..... kit ..... 11.95



**OIL PAN BOLT KIT**

Zinc-plated, grade 5, hex flange-head bolts. Kit includes (6) 5/16" - 18 x 3/4" and (18) 1/4" - 20 x 1/2" bolts.

'71 - '77 ..... 302 ..... 6087 ..... kit ..... 17.95



AK1029

AK1039

**VALVE COVER MOUNT KITS**

Dress up your engine with this stainless steel valve cover mounting kit. Each kit contains (12) stainless steel 3/8" hex washer head bolts and (12) 1/4" internal tooth stainless steel lock washers.

**NOTE:** Steel kits are for use with steel valve covers only, and aluminum kit are for use with aluminum valve covers only.

Fits all small-block Windsor V8s.

**With Steel Valve Covers**

Contains 1/4" x 5/8" bolts.  
..... AK1029 ..... kit ..... 9.95

**With Aluminum Valve Covers**

Contains 1/4" x 3/4" bolts.  
..... AK1039 ..... kit ..... 9.95

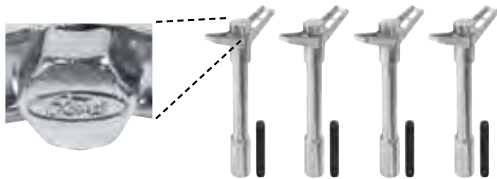

**VALVE COVER BOLTS**

For fast removal of valve covers. Chrome ends feature Ford oval logo. Amount required varies with vehicle. Set of 4.

Fits all chrome V8 valve covers.

..... M6680A302 ..... set ..... 32.95



8913

**LOCKING HEADER BOLTS**

Double hex heads. 16 bolts per kit.

'70 - '77 Small-block.  
3/8", 16 x 3/4".  
..... 8913 ..... kit ..... 69.95  
3/8", 16 x 1".  
..... 8913A ..... kit ..... 74.95



**UNDERDASH WIRING LOOM CLIP**

Fits various Ford and Mercury vehicles. Attaches to firewall / fender apron and snap closes around loom.

..... 377986S ..... ea ..... 1.50



**NEUTRAL SAFETY SWITCH MOUNTING BOLTS**

Set of 2 bolts with star washers.

Ford / Mercury with C4 or C6 A/T and transmission-mounted neutral safety switch.

..... 42746-S ..... pr ..... 3.95

**Transmission / Clutch Hardware**



**SHIFT LINKAGE REPAIR KIT**

Kit includes 3 each of studs, nuts, washers, and pins.

'71 - '76 '71 - '73 Maverick 3 speed; '73 - '76 Maverick M/T with floor shift and '71 - '72 Comet M/T.

..... C5ZZ-7285RPK ..... kit ..... 22.95



**FLYWHEEL BOLTS AND WASHERS**

Includes 6 bolts and 6 washers. 7/16" - 20 x 1". Grade 8.

..... 912 ..... set ..... 14.95



**FLEXPLATE BOLTS AND WASHERS**

Includes 6 bolts and 6 washers. 7/16" - 20 x 1 3/16".

..... 6711 ..... set ..... 19.95



**High Performance**

7/16" - 20 x .680". Superior to OEM fasteners and rated at 180,000 PSI, these bolts are forged from aerospace alloy steel before machining. Features include black oxide finish, 12-point head design and a larger-than-OEM shank diameter. Does not include washers. Set of 6.

289 - 400.

..... 100-2901 ..... set ..... 16.95



**PRESSURE PLATE BOLTS AND WASHERS**

Includes 6 bolts and 6 washers. 5/16" - 18 x 1".

'70 - '77 V8 ..... 911 ..... set ..... 14.95



**U-JOINT REPAIR KIT - UNIVERSAL**

This universal repair kit is for driveshaft u-joints with 1 1/8" O.D. bearings. Kit includes (1) 1 1/4" U-bolt; (2) 5/16" - 18 hex nuts; (2) 5/16" lock washers.

With driveshaft u-joints that have 1 1/8" O.D. bearings.  
..... 81004 ..... kit ..... 4.95

Suspension / Steering Hardware



STRUT ROD NUT SET

For the under-body end of the strut rod. Includes two inner nuts (1 1/16" - 18 x 1 1/8", serrated) and two outer nuts (1 1/16" - 18 x 1").

'71 - '77 ..... AK1031 ..... set..... 14.95



PITMAN ARM-TO-STEERING GEAR NUT

Holds the pitman arm to the steering gear sector shaft. 7/8" - 14, 1 5/16" hex.

'70 - '77 with 1 1/8" sector shaft. ..... AK1032 ..... ea ..... 4.95



REAR LEAF SPRING BAND CLAMP SET

This set includes 2 short bands, 2 medium bands, 2 long bands and 6 rubber insulators. Used with 2 1/2" wide spring with 4 leaves.

'71 Comet. ..... C4DZ-5724A ..... set..... 39.95

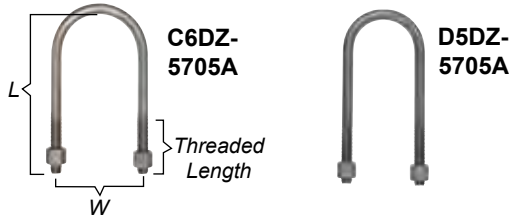

REAR SPRING U-BOLTS

Includes nuts. Requires 4 per vehicle.

**NOTE:** Please verify the measurements of your u-bolt before ordering. To get u-bolt width, measure plate holes center to center.

'70 - '74 '70 - '74 Maverick; '71 - '72 Comet. 5 7/8" long, top inside to end; 3 1/4" wide, center to center. Bolt size: 7/16" - 20 threads / inch x 2" threaded length. ..... C6DZ-5705A ..... ea ..... 9.95  
 '75 - '77 6" long, top inside to end; 2 3/4" wide, center to center. Bolt size: 7/16" - 20 threads / inch x 2 1/8" threaded length. ..... D5DZ-5705A ..... ea ..... 8.95



REAR LEAF SPRING CENTER BOLTS

Correct center bolts that hold together the leaves of the rear leaf springs. 5/16" - 24 x 1.39", .5" O.D. Package of 2 bolts, 2 nuts and 2 washers. Requires 1 package per vehicle.

..... 378683SKT ..... kit..... 9.95

Brake Hardware



BRAKE HOSE CLIP SET

Set of 3.

'70 - '77 ..... BHC101 ..... set..... 5.95



QA2514

BRAKE SELF-ADJUSTER REPAIR KITS

Each kit includes screw assembly, lever spring, cable, and rubber plug. Each kit does 1 wheel.

'70 - '77 With 10" shoes. Front or rear.  
 LH. ..... QA2514 ..... kit..... 16.95  
 RH. ..... QA2515 ..... kit..... 15.95



BRAKE DRUM HARDWARE KIT

Includes springs and hold-down kit.

'71 Comet front with 10" x 2 1/4" brakes and rear with 10" x 2" shoes. Requires 2 per vehicle. ..... H7045 ..... kit..... 19.95



FRONT SPINDLE LOCK NUT KIT

This universal kit includes (1) 3/4" - 16 nut; (1) washer; (1) retainer; (1) cotter pin. This kit will work with most of the applications above but check your spindle thread size before ordering.

'70 Maverick before 8/24/69. .... 04990 ..... kit..... 7.95



REAR DRUM BRAKE PLATE MOUNTING BOLTS

Holds the backing plate to the rear axle housing. Set of 4 bolts. Requires 2 sets per vehicle. 3/8" - 24 x 1 3/16" bolt, .62" x 1.0" head.

With 8" or 9" rear end. ..... 375748S ..... set..... 5.95



PARKING BRAKE CABLE RETAINER SET

Holds the cable to the bracket, crossmember, etc. Set of 3 clips. Not all clips are used with some applications.

'70 - '77 ..... AK1030 ..... set..... 4.95



PARKING BRAKE CABLE CONNECTOR

'70 - '74 Maverick; '72 Comet. ..... C6OZ-2A790A ..... ea ..... 9.95



BRAKE LAMP SWITCH RETAINER PIN

Attaches the switch to the master cylinder.

'70 - '72 ..... 380699-S100 ..... ea ..... 3.25



**AIR CLEANER DECALS**



**200 Engine**

- '70 120 horsepower.  
.....DF941..... ea..... 9.00
- '70 Has I.D. #D0ZF-9C611-D and is blue with white lettering.  
.....DF1297..... ea..... 8.50
- '70 Has no I.D. number and is dark metallic blue with black lettering. Not as OEM.  
.....DF59..... ea..... 8.50
- '71 .....DF560..... ea..... 9.00
- '72 - '73 1/V .....DF854..... ea..... 9.00



**250 Engine**

- '70 - '73 250 cubic inches.  
.....DF172..... ea..... 9.00
- 1/V .....DF1457..... ea..... 8.50
- '74 - '75 1/V .....DF643..... ea..... 9.00

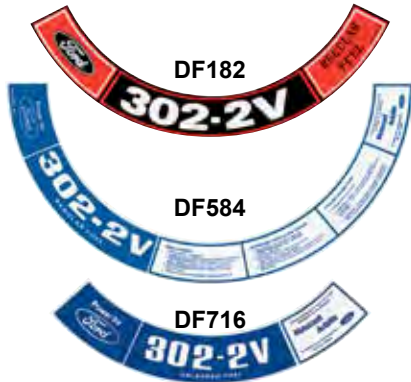

**302 Engine**

- '71 2/V regular fuel.  
.....DF182..... ea..... 9.00
- '71 4/V premium fuel.  
.....DF183..... ea..... 9.00
- '72 - '73 2/V regular fuel.  
.....DF253..... ea..... 9.00
- '72 - '73 4/V regular fuel.  
.....DF254..... ea..... 9.00
- '73 After 1/1/73. 2/V regular fuel.  
.....DF584..... ea..... 9.00
- '76 - '77 2/V unleaded fuel.  
.....DF716..... ea..... 9.00

**AIR CLEANER DECALS CONTINUED**



**Autolite Replacement Parts**

- '70 - '72 .....DF325..... ea..... 8.50



DF607



DF608

**AFTERMARKET VALVE COVER DECALS**

- Ford Powered by 302. DF607..... pr..... 9.50
- Ford Powered by 302 High-Performance.  
.....DF608..... pr..... 9.50
- Ford Powered by 302 Windsor.  
.....DF614..... pr..... 9.50

**ENGINE COMPARTMENT DECALS**



DF435



DF697

**A/C Charge**

- '71 .....DF435..... ea..... 9.00
- '74 - '77 .....DF697..... ea..... 9.00

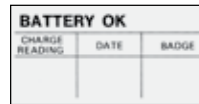

**Battery Test OK**

- '70 - '77 .....DF194..... ea..... 8.00



DF224



DF715

**Coil**

- '70 - '72 Autolite®. DF224..... ea..... 9.00
- '72 - '77 Motorcraft®  
.....DF715..... ea..... 9.00



DF348



DF714

**Voltage Regulator**

- '70 - '72 Autolite®. Yellow print.  
.....DF348..... ea..... 9.00
- '72 - '77 Motorcraft®. Silver print.  
.....DF714..... ea..... 9.00

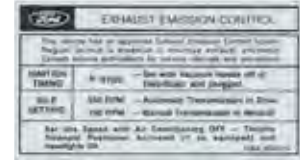

DF772



DF763

**EMISSION DECALS**

- '70 200 / 250. 10/1/69 through 1/1/70.  
.....DF772..... ea..... 9.00
- '71 200 M/T or A/T.  
.....DF666..... ea..... 9.00
- '71 302 2/V M/T or A/T.  
.....DF763..... ea..... 9.00
- '72 302 2/V M/T or A/T.  
.....DF843..... ea..... 9.00

**INTERIOR DECALS**



DF1216

**New Car Window Price Stickers**

- Sold blank; customer must fill in information.
- '71 .....DF1243..... ea..... 9.00
- '76 .....DF1216..... ea..... 9.00



DF1167

**New Car Factory Build Sheets**

- Sold blank; customer must fill in information.
- '71 .....DF1381..... ea..... 9.00
- '72 .....DF1214..... ea..... 9.00
- '77 .....DF1167..... ea..... 9.00

**INTERIOR DECALS CONTINUED**

Front



Back

**Sunvisor Sleeve – Starting Instructions**

'74 .....DF1508..... ea..... 9.00



**“Get It Together” Seat Belt Window Decal**

Applied to the lower rear corner of front door windows.

'75 – '77 .....DF879..... ea..... 8.50



**Glove Box “Maintenance Schedule ‘B’” Decal**

'76 – '77 .....DF1287..... ea..... 8.50

MAVERICK		RECOMMENDED TIRE SIZE and INFLATION PRESSURE	
MODEL	YEAR	FRONT	REAR
170 x 300	1970-1977	8.00-14 34 36	8.80-14 28 26
FULL RATED MAXIMUM LOAD 2000 LBS.			
MODEL	YEAR	FRONT	REAR
ALL	700	4	2 100

DF1235

MAVERICK		RECOMMENDED TIRE SIZE and INFLATION PRESSURE	
MODEL	YEAR	FRONT	REAR
4.0000	1970-1977	8.00-14 34 36	8.80-14 28 26
4.0000	1970-1977	8.00-14 34 36	8.80-14 28 26
4.0000	1970-1977	8.00-14 34 36	8.80-14 28 26
FULL RATED MAXIMUM LOAD 2000 LBS.			
MODEL	YEAR	FRONT	REAR
ALL	700	4	2 100

DF1245

MAVERICK		RECOMMENDED TIRE SIZE and INFLATION PRESSURE	
MODEL	YEAR	FRONT	REAR
4.0000	1970-1977	8.00-14 34 36	8.80-14 28 26
4.0000	1970-1977	8.00-14 34 36	8.80-14 28 26
4.0000	1970-1977	8.00-14 34 36	8.80-14 28 26
FULL RATED MAXIMUM LOAD 2000 LBS.			
MODEL	YEAR	FRONT	REAR
ALL	700	4	2 100

DF949

**Tire Pressure**

Applied to the end of the RH front door above the latch mechanism or on the jamb below the striker plate.

'70 – '71 From late '70.  
 .....DF1235..... ea..... 9.00  
 '72 .....DF1245..... ea..... 9.00  
 '73 .....DF949..... ea..... 9.50  
 '77 .....DF1506..... ea..... 9.00

**TRUNK DECALS**

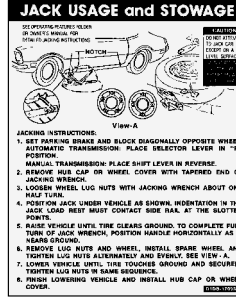

DF544



DF1213

**Jack Instructions**

'70 .....DF943..... ea..... 8.50  
 '71 – '72 .....DF544..... ea..... 6.00  
 '73 – '76 .....DF1213..... ea..... 8.50  
 '77 .....DF962..... ea..... 8.50

**EXTERIOR DECALS**



**“Grabber” Fender Decals**

'71 – '72 Orange / black.  
 .....DF914..... ea..... 13.50  
 Yellow / black.  
 .....DF915..... ea..... 13.50  
 Silver / black.  
 .....DF916..... ea..... 13.50



DF816

DF815

**Stallion Fender Decals**

'76 – '77 LH.....DF816..... ea..... 17.50  
 RH.....DF815..... ea..... 17.50



**Sprint “U.S.A.” Shield Quarter Panel Decal**

Red, white and blue shield with gold trim. Applied to rear quarter panel, above the marker lamp.

'72 Maverick Sprint.  
 .....DF391..... ea..... 10.50

**MISCELLANEOUS DECALS**



DZ5

**Autolite Spark Plugs Circle**

4" .....DZ5..... ea..... 9.00  
 6 1/2" .....DZ4..... ea..... 10.00



DZ115

**Ford Drag Team**

5" .....DZ115..... ea..... 9.00  
 8" .....DZ116..... ea..... 10.50



**Ford Oval**

3 1/2" .....DF361..... ea..... 9.00  
 6 1/2" .....DF362..... ea..... 8.50  
 9 1/2" .....DF363..... ea..... 9.00  
 17" .....DF364..... ea..... 10.50



DZ114

**“Muscle Power” Decals**

Inside window.  
 .....DZ113..... ea..... 10.50  
 Exterior decal.  
 .....DZ114..... ea..... 10.50

**Miscellaneous Window Decals**



1 1/2" x 2 1/2" Autolite Ford.  
 .....DZ120..... ea..... 9.00



3" Genuine Ford Parts.  
 .....DF531..... ea..... 8.00

# NEW TITLES FOR 2021

## Book Sales Policy

Once the plastic cover is unsealed on a book, it is no longer returnable.



### HUBERT PLATT: FAST FORDS OF THE "GEORGIA SHAKER"



By Allen Platt. Foreword by Linda Vaughn. Details of the life and career of this legendary drag racer. Read how the once-Chevy driver moved over to Ford and stayed until his retirement. This one-time moonshine runner raced some of the biggest names in Ford muscle cars of the era and was inducted into the NHRA Hall of Fame in 1986. Includes many color photos. Sftbd.

191 pgs ..... B253977 .....ea ..... 32.95

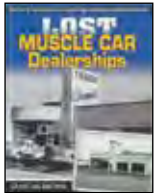

### LOST MUSCLE CAR DEALERSHIPS



By Duncan Brown. Chronicles the history of one-time car dealerships that offered the fast muscle cars that were famous on the drag strips. These dealerships helped start the legacy of the muscle car with their creative advertising and excellent performance. Some of these dealers survive today, but, sadly, most are gone. This book preserves the story of these long-gone dealerships. Includes many color photos. Sftbd.

191 pgs ..... B254516 .....ea ..... 32.95



### 1970 FORD MODELS PRICE AND OPTIONS SHEET

Reproduction of the original paper brochure. Lists base prices and optional equipment for 1970 full-size Fords, Torino, Mustang, Thunderbird, Cortina, Maverick, Falcon, 1970½ Falcon and recreational vehicles. B&W, 4 pgs.

'70 ..... B5113 .....ea ..... 8.95



### OWNER'S MANUAL

Printed in the USA.

'71 ..... 71MAVOM .....ea ..... 16.95

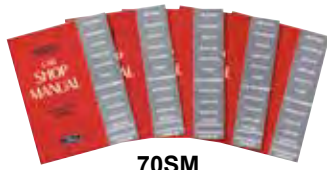

70SM

### SHOP MANUALS – REPRINTS

Covers all models of Ford and Mercury passenger cars for the given year. These 5-volume sets lay out technical information required to maintain vehicle performance: volume 1 covers the chassis; volume 2 covers the engine; volume 3 covers electrical; volume 4 covers the body; volume 5 covers pre-delivery, maintenance, and lubrication. All manuals are full-sized reprints authorized and licensed by the Ford Motor Company®.

'70 ..... 70SM .....set ..... 59.95  
 '71 ..... 71SM .....set ..... 59.95  
 '72 ..... 72SM .....set ..... 59.95



### SHOP MANUALS ONLY – CD-ROMS

Unless otherwise noted, these informational CD-ROMs contain the factory shop manuals and master parts catalogs, including illustrations, sales brochures and other historical vehicle facts for the years specified. Search for parts using categories such as brakes, sheet metal and more. View part locations from the master parts catalog. Print reference pages as needed.

Requires Microsoft® Windows® or Apple® Macintosh® OS X, Intel® processor, CD drive, and Adobe Reader or other PDF reader. NOT RETURNABLE.

'75 – '76 All Ford cars ..... CD75FDCAR .....ea ..... 29.95  
 '77 All Ford cars ..... CD77FDCAR .....ea ..... 29.95



CDSM70

### SHOP MANUALS ONLY – CD-ROMS

Contains the original shop manuals used by Ford mechanics, reproduced in electronic form. Includes illustrations, photographs and diagrams.

Requires Microsoft® Windows® or Apple® Macintosh® OS X, Intel® processor, CD drive, and Adobe Reader or other PDF reader. NOT RETURNABLE.

'70 Maverick ..... CDSM70 .....ea ..... 21.95  
 '71 Maverick ..... CDSM71 .....ea ..... 21.95  
 '72 Maverick ..... CDSM72 .....ea ..... 21.95  
 '73 Maverick ..... CDSM73 .....ea ..... 21.95



### FMX AUTOMATIC TRANSMISSION DIAGNOSIS, SERVICE AND TRAINING MANUALS – CD-ROM

Three Ford manuals in one CD-ROM. Includes *FMX Automatic Transmission Diagnosis and Service (Course 1715-108)*, *FMX Transmission Principles of Operation (Course 1715-106-INN1)*, and *Automatic Transmission Diagnosis – Programmed Instruction Book (Volume 70 S6-L2, Course 7530)*. These manuals were used to instruct Ford techs in the operation, diagnosis, and service of FMX transmissions. With step-by-step procedures, the manuals contain material that was in effect at the time of approval for printing. Officially licensed by Ford.

Requires Microsoft® Windows® or Apple® Macintosh® OS X, Intel® processor, CD drive, and Adobe Reader or other PDF reader. NOT RETURNABLE..... CD10174.....ea ..... 12.95



### FORD SHOP TIPS MAGAZINES 1963–1973 – USB

A complete 10-year collection of *Shop Tips* magazine, a Ford technical service publication provided to servicemen in service stations and independent garages to help mechanics with the servicing of Ford vehicles. Begins with the October 1963 issue and ends with August 1973. Each issue is jam-packed full of shortcuts, tips, and tricks to make repairs fast and easy. Covers both car and truck models. Officially licensed by Ford.

Requires Windows, Mac, or Android operating system with USB 2.0 or higher port and PDF viewer software. It is recommended that you have at least 128MB of RAM and hard drive storage space. It is also advisable to have the latest version of Adobe Reader DC. NOT RETURNABLE..... USB10062 .....ea ..... 14.95



**FORD CAR MASTER PARTS AND ACCESSORY CATALOG – DVD-ROM**

The original Ford master parts catalog, with all part numbers and illustrations for 1965–72 cars and 1966–72 Broncos, in electronic form. Includes explanations for the Ford parts numbering system, warranty plate and certification label info, body codes, hard parts, soft trim, sheet metal, exterior and interior trim colors and much more. Over 6,000 pages, 10,000 part numbers and 1,000 diagrams. Features printable pages in a high-resolution format. Requires Microsoft® Windows® or Apple® Macintosh® OS X, Intel® processor, CD drive, and Adobe Reader or other PDF reader. NOT RETURNABLE..... FCMP6572.....ea ..... 24.95

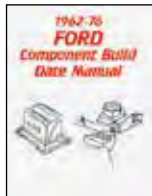

**1962–76 FORD COMPONENT BUILD DATE MANUAL**

Includes ID codes and date stamp locations for engines, automatic transmissions, electrical components, heating and air conditioning, chassis, steering, suspension, axles, brakes, shocks, and body. Line drawings and tables. Sftbd.

12 pgs..... MP377.....ea ..... 10.00



**FORD HIGH PERFORMANCE PARTS IDENTIFIER**

By Robert M. Winkelman. Authenticate any high-performance engine! This pocket-sized book lists casting numbers on engines, engine components, transmission, and differential. An invaluable reference.

88 pgs..... BOOK10.....ea ..... 9.95



**AMK PRODUCTS GUIDE TO FORD FASTENERS 1955–73**

Representing four years of research and composition, this volume covers the majority of 1955–73 Ford car and truck threaded fasteners, as well as hose clamps and many other common non-threaded fasteners. The book's primary purpose is to assist the Ford restorer in identifying original equipment fasteners found on their vehicles. Contents include: 10,000 items, history, finishes, measuring, grades, and refinishing. Spiral bound.

274 pgs. .... 9657662.....ea ..... 40.50



**FORD MECHANICAL & BODY INTERCHANGE MANUAL 1963–74**

Lists identically-used parts on all Ford, Mercury and Lincoln products. Every commonly-needed part is listed under headings such as: axle, bearing, brake, clutch, cooling, electrical, engine, fuel, suspension, transmission, wheel, body, and glass. Invaluable for the owner and restorer. Comb bound.

278 pgs. .... B102194 .....ea ..... 34.95



**FORD CARBURETOR SERVICE MANUAL**

Compiled from multiple sources – Ford, among others – and features plenty of detailed information and diagrams for rebuilding, cleaning, and adjusting Ford, Autolite, and Motorcraft carburetors.

'70 – '74 with model 2100 2/V carburetor.  
78 pgs..... 2100SM .....ea ..... 9.95

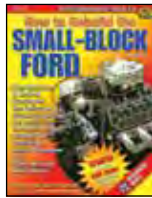

**HOW TO REBUILD THE SMALL-BLOCK FORD**

By George Reid. Takes you step-by-step through the process of rebuilding a small-block Ford engine. Go from planning your rebuild, disassembly, and inspection through choosing the right parts, machine work, assembling your engine, first firing and break-in. Gives helpful hints and tips on performance upgrades, including cams, heads, ignition and more. Covers Ford engines 221, 260, 302, Boss 302, 351W, 351C, 351M and 400M. 600 illustrations. Sftbd.

144 pgs. .... B932494 .....ea ..... 32.95



**B116664**



**B116661**

**MUSCLE CAR & HI-PO ENGINES**

From *Hot Rod* magazine comes tips for “tuning up” as well as power secrets of the fabulous muscle engines of the '60s and '70s. Information and advice packed into over 20 different articles on how to increase horsepower for your muscle car. 180 illustrations. Sftbd. 100 pgs.

Ford 289, 302, Boss 302, 351W. B116664 .....ea ..... 24.95

Ford 351C and Boss 351..... B116661 .....ea ..... 24.95

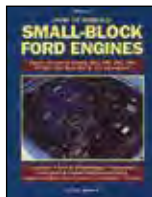

**HOW TO REBUILD SMALL-BLOCK FORD ENGINES**

By Tom Monroe. Complete guide to rebuilding any 221, 260, 289, 302 and 351W Ford engine. Parts inspection, diagnosis, reconditioning, and assembly are outlined in simple text. Hundreds of photos, charts, and diagrams visually walk you through the entire rebuild. Also covers tune-ups to maximize performance and economy, and parts interchanging to help identify all parts and determine which ones can or cannot be swapped. 567 illustrations. Sftbd.

160 pgs. .... 45089.....ea ..... 19.95



**FORD ENGINE BUILDUPS 302, 351, 4.6, 5.4**

Compiled by the expert tech editors and writers at *Muscle Mustangs and Fast Fords* magazine. This book features 20 chapters of the latest technical information on how to build horsepower for the 302 small-blocks to the 4.6 L and 5.4 L modular V8s.

Buildups include a target goal of performance and horsepower levels, a list of components, and combinations on how to achieve them. Covers 1968–95 302 / 351 small-blocks and 1996–2008 4.6 L / 5.4 L modular engines. Sftbd.

154 pgs. .... HP1531.....ea ..... 24.95

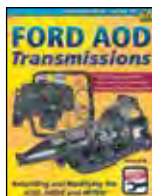

**FORD AOD TRANSMISSIONS: REBUILDING AND MODIFYING THE AOD, AODE AND 4R70W**

By George Reid. A complete step-by-step rebuild manual demonstrating the complete process of removing the transmission from the vehicle, disassembly and cleaning, reassembly, installation, and road testing. This book is great for those who already have the AOD transmission and want to add performance modifications, or for those who want to replace their old C4 or C6 in their classic machines. Includes many color photos. Sftbd.

144 pgs. .... B251140 .....ea ..... 24.95

**Can't decide on a gift idea?**

**How about an Auto Krafter's Gift Certificate?**  
They are available in your choice of dollar amount.  
Check online or ask your sales associate today.



**HOW TO REBUILD AND MODIFY FORD C4 AND C6 AUTOMATIC TRANSMISSIONS**

By George Reid. A complete step-by-step guide to rebuilding C4 and C6 automatic transmissions. Takes you through the production history to make you aware of changes you will need to know when rebuilding your transmission. Covers removal, dis-

assembly, reassembly and installation. Also included are troubleshooting and sources chapters, and many color photos. Sftbd.

144 pgs. .... B709825 .....ea ..... 24.95



**HIGH-PERFORMANCE DIFFERENTIALS, AXLES & DRIVELINES**

By Joseph Palazzolo. Helps you buy and install the proper drivetrain for almost any vehicle and application. Often an owner will build a high-performance engine that the driveline components cannot handle. This guide covers everything you need to know to

select proper gear ratio, rebuild differentials, and match the proper driveline components with your engine power output. Includes many color photos. Sftbd.

144 pgs. .... B191543 .....ea ..... 24.95

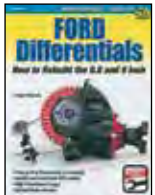

**FORD DIFFERENTIALS: HOW TO REBUILD THE 8.8 AND 9 INCH**

By Joseph Palazzolo. Takes you through the process of identification, disassembly and assembly of the two most popular and best high-performance differentials on the market. After many miles and high-performance use, axle assemblies need to be

rebuilt. Palazzolo guides you step by step in your rebuild project. He explains the work for limited slip and open differential disassembly, inspection, reassembly and final calibration. Includes lots of color photos, illustrations and charts. Sftbd.

144 pgs. .... B250389 .....ea ..... 24.95



**METAL FABRICATOR'S HANDBOOK**

By Ron and Sue Fournier. Covers body work, welding tips, hammer-forming, roll bars and roll cages, exhaust header design and construction, metal shaping tools and techniques, to mention a few. Includes detailed pictures, a glossary of industry terms, and a complete suppliers index. Sftbd.

176 pgs. .... B868709 .....ea ..... 19.95



**AUTOMOTIVE BODYWORK AND RUST REPAIR**

By Matt Joseph. Helps you plan and successfully repair your bodywork project. The author informs you on both simple and more difficult sheet metal repairs. This guide teaches you proper tool selection, cleaning and preparing metal, fabrication, welding, and finishing. Includes many color photos. Sftbd.

160 pgs. .... B191546 .....ea ..... 24.95

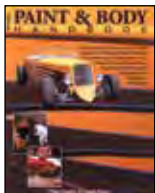

**PAINT & BODY HANDBOOK**

By Don Taylor and Larry Hofer. Everything needed to get professional-looking results, from repairing a small dent to stripping and painting a whole car. Covers tools, welding techniques, choosing and using paint and equipment. Clear detailed photos. 350 illustrations – 16 in color. Sftbd.

144 pgs. .... 40220 .....ea ..... 19.95

**DVD Sales Policy**

Once the tamper seal on the DVD box has been broken, it is no longer returnable. Exceptions will be made if the DVD is defective and cannot be viewed. If you receive a defective DVD and wish to return it, please enclose a statement specifying the defect along with the disc. Defective DVD will be replaced (only) at no additional charge.



**Classic Drag Racing Videos**

**DRAG RACING – WHEN IT WAS FUN!**

Features racing from the 1960s at New York and Pennsylvania regional drag strips. The action includes racing at Pocono Drag Lodge, Pocono International Raceway, Vargo, Tri-Cities, and many others. You will see a variety of Funny Cars, Gassers, Altered, Dragsters, Stockers and Super/Stocker. Included are interviews with big-name racers, along with special-interest stories. Real car sounds have been dubbed in, and narration is included.

2 hours 3 minutes ..... DVD151 .....ea ..... 19.95



**1970 SUPER STOCK NATIONALS**

Begins with a look at the history of York US 30 Dragway and the Super Stock Nationals, examining the 1950s style of racing, then moves on to the most successful independent one-day race of all time, the 1965 Super Stock Nationals. Coverage continues through every year up to the 1970 Super Stock Nationals. Great camera coverage! One of the best nostalgia DVDs of all time. Fully narrated.

120 minutes ..... DVD62 .....ea ..... 19.95

**RUN WHAT YOU BRUNG – CECIL COUNTY**

This DVD includes rare footage of racing events at the Cecil County Drag O Way in Rising Sun, Maryland. Features match races from 1965–67, Mr. Factory Super Stock Showdown from 1966 and a S/S and FX Invitational race from 1965. You will see some top drivers including Bud Shellenberger, Phil Bonner, "Fast" Eddie Shartman, Bill Lawton, and many more. Real car sound has been dubbed in to give this DVD the realistic sounds of the golden age of drag racing.

99 minutes ..... DVD135 .....ea ..... 19.95

**NHRA SPRING NATIONALS 1965–1968**

This DVD looks back at the first 4 NHRA Spring Nationals which were held at Bristol, Tenn. and Englishtown, NJ. Top Fuel, Top Gas, Funny Car, Super Stock, and other eliminators are included in this highly detailed DVD. Hours of research went into the script, and the result is a totally narrated tape full of historic and factual information.

118 minutes ..... DVD132 .....ea ..... 19.95

**THE S/S & FX ERA 1963–1967**

This fully-narrated DVD contains original movie footage of the S/S and FX racers of the era. See "Dyno" Don's '64 A/FX Comet wagon, Sox & Martin's '64 A/FX Comet, Hemi's Cuda, '66 fliptop Comet roadster, '67 FT SOHC Comet and many more. Also features the first and second NHRA Spring Nationals at Bristol in 1965 and 1966. Special interviews with Buddy Martin, Ronnie Sox, and Jake King are also included.

80 minutes ..... DVD131 .....ea ..... 19.95



**1:24 SCALE DIE-CAST '74 MAVERICK 2-DOOR**

Features opening doors and hood, functional steering, and a detailed engine compartment with a six-cylinder engine. Interior is black.

**NOTE:** Small parts – not recommended for children under 6 years old.  
Red ..... MM73326RED .....ea ..... 39.95

**Clothing**



**HTMV-01**



**HTMV-02**



**HTMV-06**

**MAVERICK LOGO HATS**

Black hat with the Maverick logo embroidered in khaki and a khaki band around the brim. 55% polyester / 45% polypropylene. Adjustable.  
..... HTMAV-01 .....ea ..... 19.95

Medium blue hat with Maverick logo embroidered in white.  
..... HTMV-02 .....ea ..... 19.95

Beige hat with the Maverick logo embroidered in black. Navy trim around the brim. 55% polyester / 45% polypropylene. Adjustable.  
..... HTMV-06 .....ea ..... 19.95

Navy blue hat with the Maverick logo embroidered in white. 55% polyester / 45% polypropylene. Adjustable.  
..... HTMV-08 .....ea ..... 19.95



**HATCM**



**HATCM-06**

**COMET LOGO HATS**

Navy blue hat with Comet logo embroidered in white.  
..... HATCM .....ea ..... 19.95

Stone-colored with navy blue trim around the edge of the brim and logo embroidered in navy blue. .... HATCM-06 .....ea ..... 19.95



**HH046YLW**



**HH046RED**



**HH046BLU**

**FORD INFERNO HATS**

Black hat with black and white Ford oval and yellow flames on brim.  
..... HH046YLW .....ea ..... 19.95

Black hat with black and white Ford oval and red flames on brim.  
..... HH046RED .....ea ..... 19.95

Black hat with blue and white Ford oval and blue flames on brim.  
..... HH046BLU .....ea ..... 19.95



**FORD OVAL CAMOUFLAGE HAT**

Camouflage mesh hat with khaki Ford oval on the front. Adjustable.  
..... HH120CAMO .....ea ..... 18.95



**"FIRST ON RACE DAY" FORD RACING HAT**

Black hat with black trim and the slogan "First On Race Day" in white over a blue and white Ford oval with red "Racing" underneath.  
..... HH008BLK .....ea ..... 16.95

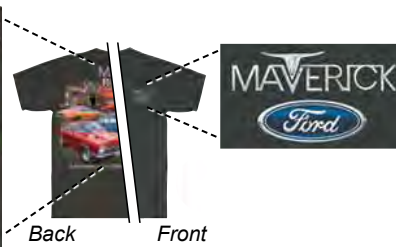
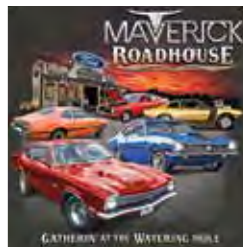

Back Front

**FORD MAVERICK ROADHOUSE T-SHIRTS**

Made of high-quality 50% cotton / 50% polyester. Features highly-detailed, full-size screen print design. Color: charcoal gray.

**Full Back Design:** "Maverick Roadhouse" and "Gatherin' at the Watering Hole" slogans, along with five different Mavericks.

**Front "Pocket" Design:** Maverick over the Ford oval logos.

S .....	FMMAVGYSM .....	ea .....	19.95
M .....	FMMAVGYM.....	ea .....	19.95
L .....	FMMAVGYL.....	ea .....	19.95
XL.....	FMMAVGYXL .....	ea .....	19.95
XXL.....	FMMAVGYXXL.....	ea .....	21.95
XXXL.....	FMMAVGYXXXL.....	ea .....	22.95

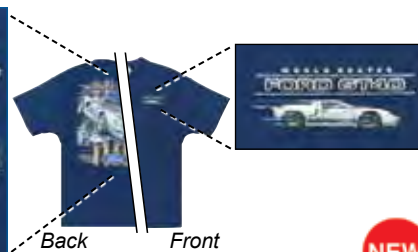

Back Front



**"FORD GT40: WORLD BEATER" T-SHIRTS**

Made of high-quality 100% cotton and featuring highly-detailed screen print designs. Color: navy blue. Ford officially licensed product.

**Full Back Design:** "Ford GT40: World Beater" slogan over three GT40 images against an American flag background, with the Ford logo and "LEMAN'S 1966 FIRST, SECOND & THIRD" underneath.

**Front "Pocket" Design:** Ford GT40 logo.

Medium .....	FMWB2NVBM.....	ea .....	19.95
Large .....	FMWB2NVBL.....	ea .....	19.95
X-Large .....	FMWB2NVBXL .....	ea .....	19.95
XX-Large .....	FMWB2NVBXXL.....	ea .....	21.95
XXX-Large .....	FMWB2NVBXXXL .....	ea .....	22.95

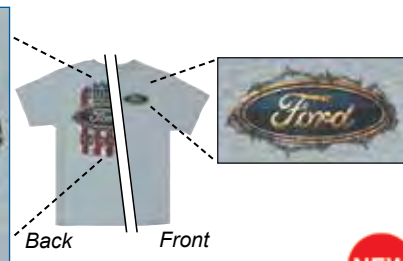

Back Front



**"THIS IS FORD COUNTRY" T-SHIRTS**

Made of high-quality 90% cotton / 10% polyester featuring highly-detailed screen print designs. Color: Oxford Gray. Officially licensed by Ford.

**Full Back Design:** "THIS IS [Ford] COUNTRY" surrounding a Ford oval ringed by barbed wire, with rustic American flag in the background.

**Front "Pocket" Design:** Rustic Ford oval logo surrounded by barbed wire.

Medium .....	FMFCFOM.....	ea .....	19.95
Large .....	FMFCFOL.....	ea .....	19.95
X-Large .....	FMFCFOXL.....	ea .....	19.95
XX-Large .....	FMFCFOXXL.....	ea .....	21.95
XXX-Large .....	FMFCFOXXXL.....	ea .....	22.95



**FORD OVAL LICENSE PLATE FRAME**

High-quality tripe-plated chrome with a Ford oval in each lower corner.

..... WL021C.....ea ..... 29.95



15410



14969



KC021

**FORD LOGO KEY RINGS**

**Stainless Steel**

Features a mirrored finish, stainless steel body, and a satin Ford oval name plate. Comes boxed.

Valet style..... 15410.....ea ..... 12.95  
 Teardrop style ..... 14969.....ea ..... 10.95

**Chrome**

Features a quality die-cast, 3" Ford oval emblem.

..... KC021.....ea ..... 6.95

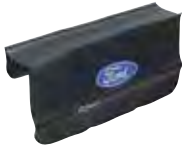

**FORD PERFORMANCE FENDER COVER**

Black with blue and white Ford oval with "PERFORMANCE" in red. Special tool trough keeps tools in place. Acid- and grease-resistant. Measures 26" x 33" and has a non-skid soft backing.

..... M-1822-A7.....ea ..... 29.95



**FORD LOGO GARAGE STOOL**

This stool has chrome-plated legs and would be great for a garage, shop, store, game room, or a work station. It also has a foot rest and a black seat featuring the blue Ford logo in white letters. Unassembled.

14" W x 29.5" H  
 ..... 4751R01.....ea ..... 69.95



**GORILLA® POWER LUG WRENCH**

Removes the tightest lug nuts with ease.

Constructed from hardened steel, the telescoping handle extends to 21" for maximum leverage. Includes a 3" extension and 2 thin wall sockets—19 mm (3/4"), 21 mm (13/16")—that work on both deep-dish wheels and all recessed lug holes. .... 1334.....ea ..... 31.95



**WINDSHIELD MOULDING REMOVAL TOOL**

Can be used on most Ford vehicles. Metal ends with plastic grip in the middle. .... 2107.....ea ..... 11.95

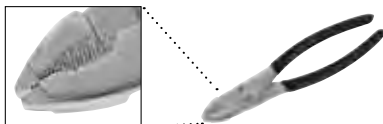

**MOULDING CLIP INSTALLATION PLIERS**

Zinc-plated pliers made to install flare-type moulding clips. The tips are designed to take hold and crimp the outer center tabs of the clip. Features rubber grip handles..... TL300.....ea ..... 14.95



**WINDSHIELD REMOVAL TOOL**

Features a steel cable pull handle. Cuts the butyl adhesive caulking around glass with a specially-designed, tempered steel blade. .... WSR92065.....ea ..... 19.95



**WINDSHIELD REMOVAL WIRE KIT**

For cutting and removing front and rear auto glass. Contains 213' of 1/4 lb. wire, wooden handles and instruction sheet.

..... 0564.....ea ..... 14.95



**PRIORITY START**

Maintain your starting power! When key is off, this device monitors, detects, and automatically disconnects any drain on the battery. Turn key to start, and it automatically reconnects, starting safely from inside your vehicle. Fits any 12 volt vehicle application..... PSIDP12.....ea ..... 79.95



**MAXOUT 1 LB. DRY CHEMICAL FIRE EXTINGUISHERS**

Can be used on the types of fires common to automotive environments. UL rated 2B:C and tested to ANSI/UL711 and ANSI/UL299. The dry chemical is proven protection against flammable liquid fires and will not conduct electricity back to the operator. Steel cylinder with an easy-to-operate trigger handle with locking pin. Features an easy-to-read gauge, metal valve, and a steel mounting bracket. Measures approximately 11 1/2" x 4" x 4". Rechargeable and non-toxic. 6-year limited manufacturer's warranty. Made in the USA.

**MX100B MX100R**

**NOTE:** Shipped via ground services only; cannot be shipped via air.

Gloss black..... MX100B.....ea ..... 109.95  
 Classic red ..... MX100R.....ea ..... 119.95

**Chemicals and Adhesives**

**NOTE:** These products cannot be shipped via air. They must be shipped only via ground services.



**KBS GOLD STANDARD® TANK SEALER**



A superior, single-component, ready-to-use sealer formulated for coating the inside of metal, aluminum, and fiberglass tanks. Widely recommended and easy-to-use, this single-application coating cures into a tough fuel-impervious seal. The entire tank, including pinholes and weld seams, is permanently sealed to prevent rust and corrosion and clogged carburetors. Its rock-hard finish remains flexible to withstand vibration and the repeated expansion and contraction of the tank! Other sealers are little more than paint or adhesive-type coatings which have poor sealing abilities, especially when exposed to today's fuels. Gold Standard® Tank Sealer is impervious to all fuels, alcohol additives, and most solvents. Withstands temperatures of up to 600° F. Contains no methyl ethyl ketone. Seals up to a 25 gallon tank. Made in the USA.

**Quart Only**

..... KBS5400.....ea ..... 34.95

**Full Kit**

Includes (2) quarts of KBS Klean® (a water-based, heavy-duty, cleaner/degreaser); (1) quart of Rust-Blast® (a powerful rust remover/metal etch); (1) quart of Gold Standard Tank Sealer®; black nitrile gloves; stir stick; and detailed instructions.



..... KBS53000.....kit ..... 67.95



**PC-7® 2-PART HEAVY-DUTY EPOXY ADHESIVE PASTE**

**NEW**

Formulated for the maximum in bonding power. Exceptional adhesion to metals, ceramics, masonry, and many plastics. Designed for permanent repairs. Seal a crack in a wall, attach a hanger to a ceramic plaque, seal a leak in an oil pan, repair a granite monument, fix a leak in PVC pipe connection, create a multimedia sculpture, and thousands of other repairs. When mixed, part A (gray) and the hardener part B (black) react to form a bond of tremendous strength. Slow curing, but slow can be a good thing especially for large tasks. Working time: 60 minutes. Minimum cure time: 24 hours (48 hours for full cure).

Two 8 oz. cans ..... PC-7EAP.....ea ..... 14.95



**SEAM SEALER**

Premium-quality, fast-setting sealer with superior adhesion for interior and exterior applications (except windshields). Excellent sealer for quarter panel seams, trunk seams, wheel-house seams, floor seams, cowl seams, and door skins. Use with a cartridge applicator gun (caulking gun).

11 oz. cartridge..... AV1002 .....ea ..... 11.95



**3M™ AUTO BEDDING & GLAZING COMPOUND – BLACK**

For sealing auto body seams, between windshield rubber and the car body, and to attach door water shields. Remains permanently soft and pliable to absorb movement in the auto body. Non-hardening, water-resistant, medium-bodied product. Cleans with a dry cloth. Use with a cartridge applicator gun (caulking gun).

10 oz. cartridge..... 3M08509 .....ea ..... 15.95



**WINDO-WELD™ SUPER FAST URETHANE – BLACK**

One-part, moisture-curing adhesive that bonds replacement auto glass to car bodies. Use with a cartridge applicator gun (caulking gun).

10.5 oz. cartridge..... 3M08609 .....ea ..... 26.95



**BLACK STRIP-CALK**

Soft, non-hardening caulking material in one-foot lengths for use in all types of seams, joints and openings.

Easily thumbed into place and smoothed with finger. May be painted immediately. Has non-sag consistency for vertical and overhead applications. No shrinkage. Adheres to metal, paint, glass, and rubber. Completely waterproof. Will not crack or dry out.

Box of 60 one-foot lengths..... 08578 .....ea ..... 24.95



**WEATHERSTRIP ADHESIVE**

High-quality black adhesive. Strong, flexible and rubbery. Can withstand vibration and extreme temperature variations.

It can be used to bond automotive weatherstripping and is a great adhesive for holding paper, cork or rubber gaskets in place during installation. Not recommended for windshield or back glass weatherstrip.

5 oz. tube ..... 3M08008 .....ea ..... 8.95



**PERMATEX® TRIM ADHESIVE**

Recommended for installation of carpet, headliners, upper quarter trim panels, hood insulation, trunk mats, etc. Also recommended for repair of sunvisors or anywhere you need a good adhesive.

16 oz. aerosol ..... 82019 .....ea ..... 10.95



**MISTY® HEAVY-DUTY TRIM ADHESIVE**

Can be used on a variety of surfaces, uneven or porous, for temporary or permanent bonding. The wide web spray pattern dries clear and is waterproof and non-staining. Contains no chlorinated solvents and is ozone non-depleting. Made in the USA.

**Caution:** Please read all directions carefully. Extremely flammable and harmful if swallowed. Eye irritant. Please keep away from children.

12 oz. aerosol..... A00315 .....ea ..... 9.95



**PERMATEX® HEAVY-DUTY HEADLINER AND CARPET ADHESIVE**

Can be used to adhere foam, carpet, fabrics, plastic, rubber and various other materials. Weather- and water-resistant. Please read directions and cautions before using.

16.75 oz. aerosol..... 27828 .....ea ..... 17.50

**Paints and Related**

**NOTE:** These products cannot be shipped via air. They must be shipped only via ground services.



**VHT™ RUST CONVERTOR**

**NEW**

Specially formulated to stop rust on contact and to prevent its return. Sprays on clear and dries to a black paintable, waterproof finish. Can be used on most metal surfaces and is heat resistant up to 200° F. Please read all warnings and instructions carefully.

10.25 oz. aerosol..... SP229 .....ea ..... 10.95



**PERMATEX® RUST TREATMENT**

One-step rust treatment that destroys old rust on contact and prevents new rust. Just spray on. Within minutes, rust is replaced by a durable, black polymer coating that may be painted. Excellent protective primer. Can be used when temperature is between 50° F and 90° F (10° C and 32° C) and on surfaces which do not exceed 200° F (93° C).

10.25 oz. spray ..... 81849 .....ea ..... 9.95



**RUBBERIZED SPRAY UNDERCOATING**

This is a heavy-duty rubberized undercoating formulated to offer excellent protection, coverage and durability. Combines the flexibility and sealing properties of rubber with superior coating thickness.

16 oz. aerosol..... 135EA .....ea ..... 5.95



**KBS2400**



**KBS2500**

**KBS KLEAN® CLEANER / DEGREASER**

**KBS NEW**

A concentrated, water-based, biodegradable formula that is an excellent alternative to flammable solvents and hazardous chemicals for preparing your paint job with a clean surface. Can be diluted up to 10 times its volume. Non-corrosive, non-

toxic, environmentally safe, and phosphate-free. Safe on non-ferrous metals such as aluminum. Use it on steel, iron, fiberglass, automotive and diesel engines, and much more. A great first step in surface cleaning before painting. Perfect for the home, garage, shop, or plant to effectively remove dirt, grime, oils, lubricants, grease, waxes, scum, algae, road film, and other contaminants. Made in the USA.

Quart ..... KBS2400 .....ea ..... 11.95

Gallon ..... KBS2500 .....ea ..... 20.95





**KBS STRIP®  
PAINT REMOVER**

Aircraft-strength paint remover that sprays as a semi gel coat for fast and easy coverage, resulting in an even, unbroken film which seals and allows deep penetration through multiple layers of paint. Will cling to vertical surfaces with minimal run or sag, while offering low-odor technology. Can be washed off with water or solvent.

Removes lead-based paints, polyurethanes, lacquers, shellacs, marine finishes, and more. Stays wet and active for 2 to 4 hours. If left for an extended period and allowed to completely dry, it can quickly be reactivated by re-spraying the surface. Enough for approximately 20 to 35 square feet. Made in the USA.

Quart ..... KBS1940 .....ea ..... 28.95



**KBS SYSTEM  
SAMPLER KITS**

Everything you need to try out the complete KBS system. Contains (1) 8 oz. KBS Klean®; (1) 8 oz. RustBlast®; (1) 8 oz. RustSeal® (your choice: gloss black or satin black); black nitrile gloves; two brushes; stir stick; and complete and detailed instructions. Seals

12.5 square feet with 2 coats.

For information on the KBS Klean®, see previous page.

For information on RustBlast® and RustSeal®, see previous column.

Made in the USA.

Gloss black..... KBS50001.....kit..... 22.95  
Satin black..... KBS50002.....kit..... 22.95



**KBS RUSTBLAST®  
RUST REMOVER AND  
PRE-PRIMING ETCH**

Removes and neutralizes rust while pre-priming your metal before painting. Can be applied with an easy-to-use spray, submersion, or by brush. Apply at full strength to a clean surface, keeping it wet for 30 to 40 minutes or longer, and watch the rust,

corrosion, metal oxides, and tarnishing vanish before your eyes. Use it on steel, cast iron, brass, aluminum, copper, steel alloys, fiberglass, and more. Great second step before painting, and after using the KBS Klean®. Will acid etch the surface and leave a zinc phosphate coating to ensure additional rust protection and a strong bond with any paint. Non-flammable, non-corrosive, water-based, and biodegradable. Includes sprayer. Made in the USA.

Quart ..... KBS3400 .....ea ..... 15.95  
Gallon ..... KBS3500 .....ea ..... 30.95



**KBS FRAME  
COATER® KITS**

Everything you need to Klean, Blast, and Seal a full-size car or truck frame, or any 50 square foot area with 2 coats of paint coverage. Contains (1) quart of KBS Klean®; (1) quart of KBS RustBlast®; (1) quart of KBS RustSeal® (your choice: gloss or satin black); black nitrile

gloves; two brushes; stir stick; and complete and detailed instructions.

For information on the KBS Klean®, see previous page.

For information on RustBlast® and RustSeal®, see previous column.

Made in the USA.

Gloss black..... KBS57001.....kit..... 62.95  
Satin black..... KBS57002.....kit..... 62.95



**KBS RUSTSEAL®**

An incredible, single-component, ready-to-use, high solids content, rust preventive coating and stop-rust paint with great sealing properties. No other brand is tougher on rust! Using premium-quality materials and advanced color formulations, this high-tech performance coating is the most permanent, cost-effective solution for stopping rust and corrosion any-

place it is a problem: home, automotive, industry, fleet, farm, and more! Unlike other corrosion treatments, RustSeal® is an enhancement that lasts. Water and air are locked out, therefore oxidation cannot take hold. Great for automotive use on chassis, floor pans, wheel wells, fenders, trunks, engines, suspension parts, axles, roof drains, springs, doors—almost every part on a car or truck except the exhaust. Made in the USA.

**NOTE:** *Not intended for use as a final finish.* Repeated or prolonged exposure to direct UV light will cause cosmetic alteration to its color and sheen. Its guaranteed rust protective properties, however, will not degrade. In areas not exposed to direct UV light, such as the underside of a car, RustSeal® will seal as well as serve as a great-looking final finish. To protect against unwanted cosmetic changes, topcoat RustSeal® with any opaque (solid color) paint system.

**Pint** (covers approximately 25 square feet with 2 coats)  
Gloss black..... KBS4301 .....ea ..... 26.95  
Satin black..... KBS4302 .....ea ..... 26.95  
**Quart** (covers approximately 50 square feet with 2 coats)  
Gloss black..... KBS4401 .....ea ..... 36.95  
Satin black..... KBS4402 .....ea ..... 36.95  
Gray ..... KBS4405 .....ea ..... 36.95



**KBS MOTOR COATER®**

This high-quality, fast-drying acrylic enamel is extremely high-gloss. Easy to apply, offers superb coverage, and yields a self-leveling professional-looking finish, whether it is brushed or sprayed. Very durable, protecting your engine from chips, chemicals, and heat. Withstands temperatures up to 450° F. Will not blister, flake, crack, or peel. Oil, transmission

fluid, and gas resistant. Great for brake calipers, too. 1 pint is usually enough to do an entire engine. Made in the USA.

Pint Chevy orange..... KBS60301.....ea ..... 23.95  
Gloss black..... KBS60302.....ea ..... 23.95  
Velvet black..... KBS60312.....ea ..... 23.95



**KBS XTC® XTREME  
TEMPERATURE CONTROL  
HIGH-TEMPERATURE  
COATINGS**

High-temperature heat-resistant coating formulated specifically to protect metal surfaces operating at temperatures from 500° F (260° C) to 1,500° F (812° C). With proper preparation,

it provides outstanding adhesion, film integrity, weathering, and thermal shock-resistance throughout this entire temperature range, and is guaranteed not to burn off! It is also resistant to scratching and marring, reduces underhood temperatures as well as reducing exhaust manifold surface temperatures. Ideal for exterior applications because it resists rust when primed with KBS XTC® Primer (see next page). Can be brushed or sprayed. Great for exhaust headers, manifolds, mufflers and more. Made in the USA.

**12 oz. aerosol** (covers approximately 10 to 15 sq. ft. per coat)  
Jet black ..... KBS65102 .....ea ..... 19.95  
Cast-iron gray..... KBS65105.....ea ..... 19.95



*Here's what our customers are saying about us...*

**"Best service in automotive parts, period!"**

– Baldomero E.

**KBS XTC® XTREME TEMPERATURE CONTROL HIGH-TEMPERATURE COATINGS CONTINUED**

- 8 oz. can** (covers approximately 18 sq. ft. with 1 coat or 9 sq. ft. with 2 coats)
- Jet black ..... KBS65202 ..... ea ..... 19.95
  - Aluminum ..... KBS65203 ..... ea ..... 26.95
  - Cast-iron gray ..... KBS65205 ..... ea ..... 19.95
- Pint can** (covers approximately 36 sq. ft. with 1 coat or 18 sq. ft. with 2 coats)
- Jet black ..... KBS65302 ..... ea ..... 30.95
  - Cast-iron gray ..... KBS65305 ..... ea ..... 30.95



**KBS XTC® XTREME TEMPERATURE CONTROL HIGH-TEMPERATURE COATING PRIMER**



This silicone zinc primer prevents corrosion of metal surfaces exposed to high heat, high humidity, condensation, and salt air. Functioning like galvanizing, it locks itself to bare metal surfaces, leaving a perfect primed surface for top coating. Can be used alone as a finish paint. Free of fluorocarbons, lead, and chromates. Will cover approximately 10 to 15 sq. ft. per coat. Made in the USA.

- 12 oz. aerosol**
- Gray ..... KBS65100 ..... ea ..... 19.95



**KBS BLACKTOP® COATINGS**



A permanent, moisture-cured, UV-stable coating used primarily for top-coating surfaces sealed previously with RustSeal® (previous page) or any other paint / primer application. This high-performance protective coating is formulated specifically to withstand dulling and fading from prolonged sunlight exposure. No chalking or fading. High-temperature resistance up to 300° F. May be used alone as a resilient coating, but will not offer the ultimate rust protection unless used in combination with RustSeal®. For the best stop-rust and ultraviolet protection, first apply RustSeal® to seal permanently the surface, then top-coat with BlackTop® for an incredibly tough, professional-looking finish. Dries to a rock-hard yet flexible coating that can be applied readily to chassis, coil springs, and lightweight panels. High-heat resistant and can be applied to almost all automotive applications except exhaust systems. Made in the USA.

- 15 oz. aerosol** (covers approximately 38 sq. ft.)
- Gloss black ..... KBS8101 ..... ea ..... 22.95
  - Satin black ..... KBS8102 ..... ea ..... 22.95
- Pint can** (covers approximately 18 sq. ft. with 1 coat or 9 sq. ft. with 2 coats)
- Gloss black ..... KBS8301 ..... ea ..... 28.95
  - Satin black ..... KBS8302 ..... ea ..... 28.95
- Quart can** (covers approximately 36 sq. ft. with 1 coat or 18 sq. ft. with 2 coats)
- Gloss black ..... KBS8401 ..... ea ..... 46.95
  - Satin black ..... KBS8402 ..... ea ..... 46.95



**KBS DIAMONDFINISH® HIGH-GLOSS CLEAR COAT**



A long-lasting, moisture-cured top coat designed to add body, depth, and rich gloss to any existing top coat. Guaranteed to never yellow or crack. Can be used as a stand-alone sealant for high-weather surfaces such as wood, concrete, porcelain, or on bare metals such as polished chrome or aluminum. Very durable due to its high solids content, but will also remain permanently flexible. Apply with brush, roller, or conventional spray gun; will always have excellent flow out. Unlike other clear coats, all the hardening compounds are already contained in DiamondFinish Clear®—no measuring or mixing. Permanent UV stability and high-temperature resistance makes it suitable for motors and brake calipers. Made in the USA.

- Pint can** (covers approximately 50 sq. ft. with 1 coat)
- ..... KBS8304 ..... ea ..... 37.95
- Quart can** (covers approximately 100 sq. ft. with 1 coat)
- ..... KBS8404 ..... ea ..... 55.95



**KBS6200 KBS6400**

**KBS #1 THINNER®**



Low VOC paint thinner used for the thinning and cleanup of RustSeal® and other KBS Coatings® paints. Regular solvents may contain moisture that can adversely affect the performance of the KBS coatings. Also, keep some KBS #1 Thinner® on hand for your immediate cleanup needs. Made in the USA.

- 8 oz. .... KBS6200 ..... ea ..... 8.95
- Quart ..... KBS6400 ..... ea ..... 15.95



**KBS CAVITY COATER® WITH WAND**



A one-step, super-penetrating corrosion-inhibiting coating (CIC) for long-term protection on all metal surfaces. Provides a self-healing film that creeps into welds and seams, rendering over 4,000+ hours salt spray protection—over 4 times the protection of conventional cavity

waxes. Use with a KBS Cavity Wand (included) to give long-lasting protection for those hard-to-reach enclosed cavities, such as rocker panels, boxed frames, inside doors and fenders, deck lids, tailgates, and more. Protects against carbon fusion while lubricating parts. The 36" Cavity Wand includes a 360° spray tip that will coat approximately 125 sq. ft. at 1 mil thickness. Made in the USA.

- 17.5 oz. aerosol with wand ..... KBS75101 ..... ea ..... 34.95



**KBS PAINT SAVER® COATING PRESERVER**



A proven paint preserver that allows user-friendly long-term storing of leftover paints in the original can. Keeps paints, coatings, and clear coats from skinning over in the can, which saves money by allowing you to use the entire can of paint. Environmentally safe and very easy to use. Can save up to 75 cans of paint. Made in the USA.

- .25 oz. aerosol ..... KBS150090 ..... ea ..... 10.95



**SP391 RP102 RP103**

**PLASTI-KOTE® ANTI-RUST PRIMER**

Fast drying. Does not need to be sanded. Can be recoated any time. Gray.

- 12 oz. aerosol ..... SP391 ..... ea ..... 7.95

**HI-TEMP EXHAUST MANIFOLD PAINT**

This cast-iron gray paint is specially formulated to withstand temperatures up to 1,200° F. A must for exhaust manifolds, as it will keep them looking new for years or make old, rusty ones look factory fresh. Also looks great on headers.

- 12 oz. aerosol ..... RP102 ..... ea ..... 10.95

**OEM DETAIL / CHASSIS PAINT**

This black OEM detail / chassis paint has a semi-gloss finish and has a high pigment content for superior coverage.

- 12 oz. aerosol ..... RP103 ..... ea ..... 10.95



**DUPLI-COLOR® ENGINE PRIMER**

Resists temperatures up to 500° F (260° C). It chemically bonds to metal and will not burn off, chip, or peel. It is gasoline and oil resistant. Gray.

12 oz. aerosol..... SP228 .....ea ..... 7.95



**DUPLI-COLOR® ENGINE PAINT**

For use on valve covers and air cleaners. This enamel is highly resistant to oil and gasoline. Dries fast to a protective film that actually improves with age. When properly applied, will not crack, peel, or flake off. 12 oz. aerosol.

Old Ford blue.

SP205

215

..... SP205 .....ea ..... 7.95

Semi-gloss black.

..... 215 .....ea ..... 7.95



**VHT® ENGINE PAINTS**

These VHT® 550° F enamels are specially formulated to withstand corrosion, rust, salt spray and strong solvents. 11 oz. aerosol.

Matches dark Ford blue.

..... SP125 .....ea ..... 8.95

Flat black. Perfect for painting engine blocks.

..... SP130 .....ea ..... 8.95

SP125

Gold. Great for use on valve covers.

..... SP132 .....ea ..... 10.95



**DUPLI-COLOR® SEMI-GLOSS BLACK ENAMEL**

Use this enamel in the engine compartment or for any low-gloss black application. Offers advanced corrosion resistance and superior coverage and durability. Dries fast to a smooth finish.

12 oz. aerosol..... 361 .....ea ..... 8.95



**DUPLI-COLOR® CAST GRAY FINISH ENAMEL**

This builder's cast gray finish is a fast-drying enamel that resists oil, brake fluid and gasoline. Recommended for master cylinders, engine blocks, idler arms and brackets, strut rods, pitman arms and spindles. Withstands heat up to 500° F.

12 oz. aerosol..... SP285 .....ea ..... 8.95



**GENUINE FORD SPRAY PAINT**

This argent silver paint can be used to refinish splash pans, valve covers and other argent silver-colored metal body parts.

13 oz. aerosol..... D7AZ-19000A .....ea ..... 14.95



**VHT® CHROME PLUS SPRAY PAINT**

VHT Brilliant Metallic Paint is a unique, quick-dry formulation that produces a metallic appearance on metal, glass, or wood surfaces.

11 oz. aerosol..... SP525 .....ea ..... 9.95



**HIGH-TEMPERATURE WHEEL PAINT**

Argent silver-color high-temperature (up to 250° F) wheel paint. This paint is a chip-resistant polyurethane coating for steel or aluminum wheels.

11 oz. aerosol ..... SP188 .....ea ..... 7.95

**Cleaners**

**NOTE:** These products cannot be shipped via air. They must be shipped only via ground services.



**MIRROR GLAZE® VINYL & RUBBER CLEANER / CONDITIONER**



A complex formula that cleans, penetrates and rejuvenates, vinyl and rubber surfaces. Durable protection that screens out damaging UV rays. Restores life and color. Leaves a rich, natural sheen, unlike the shiny synthetic coating of simple protectants.

16 oz. spray M4016 .....ea ..... 12.95



**PLASTX CLEAR PLASTIC CLEANER AND POLISH**



A rich gel that restores optical clarity to rigid and flexible clear plastics. Removes light oxidation, chemical degradation, surface contaminations, stains, and light surface scratches with ease. Special highly water-resistant polymers provide long lasting durable protection to keep your clear plastics clear and beautiful longer.

10 oz. bottle ..... G12310 .....ea ..... 8.95

**Waxes and Polishes**

**NOTE:** These products cannot be shipped via air. They must be shipped only via ground services.



**KBS HEADLIGHT RESTORE KIT®**



Everything you need to restore 4 or more headlight lenses which drastically increases the visibility of fogged, yellowed, cloudy, or hazy dull-looking headlights and drastically improves their performance. Its easy-to-use single-part formulation is tougher and harder than 2-part clear coats. Self-leveling—no brush marks. Can be applied with a simple brush or spray application.

Permanent UV stability. Kit includes (1) 8oz. KBS Klean®, (1) 4oz. KBS DiamondFinish® Clear, black nitrile gloves, 2 brushes, scuff pad, stir stick, and complete and detailed Instructions. Made in the USA.

..... KBS50040 .....kit ..... 21.95



**PACIFIC COAST CAR DUSTER**

The cotton fiber dusting head, heat-treated with paraffin wax, will pick up dust and dirt from your vehicle. Safe on all surfaces. Just lightly sweep the duster over your vehicle.

Reusable and can be occasionally hand washed. Includes heavy duty plastic handle and vinyl storage bag.

**NOTE:** This is not a polishing tool. Excess pressure may cause paraffin deposits on vehicle's finish ..... 93007 .....ea ..... 16.95



**WATER BLADE**

Patented T-bar edge whisks away water. Soft grade silicone blade will not scratch.

Virtually eliminates messy towels and chamois. Dry your car or truck in one-third the time.

11" long, rigid handle ..... 2010 .....ea ..... 17.95

**2- or 4-DOOR HARDTOP** – Has no post at the door opening

**2- or 4-DOOR SEDAN** – A car with a post at the door opening

**2/B or 2/V** – 2 barrel

**2WD or 2wd** – 2 wheel drive

**3/T or 3/S/T** – 3 speed transmission

**3 or 4/S/T** – 3 or 4 speed transmission

**4/B or 4/V** – 4 barrel

**4/T or 4/S/T** – 4 speed transmission

**6/B or 6/V** – 6 barrel

**8/B or 8/V** – 8 barrel

**A/C** – air conditioning

**AFTERMARKET** – not original; made after the marketing of vehicle

**ANODIZED** – plated aluminum

**APRON** – inner panels under the hood

**A/T** – automatic transmission

**A.T.C.** – automatic temperature control

**AUTOLITE** – Ford's service division in the '70s

**BATTERY APRON** – front right-hand panel (passenger side) where the battery is mounted

**BELTLINE** – Also known as fuzzies, anti-rattlers, dew wipes, window felts. Refers to the beltline (mid-section) of the vehicle.

**BEZEL** – finish cover, rim, or outer cover

**BRAKE PROPORTIONING VALVE** – Used on front disc, rear brake cars. Not used on four-wheel drum cars. Not to be confused with a distribution block.

**B/W** – Borg Warner

**C4, C5 and / or C6** – types of automatic transmissions

**CAMMER** – an engine with an overhead camshaft (OHC)

**CFM** – cubic feet per minute of air

**CID** – cubic inch displacement

**CJ** – Cobra Jet

**C/M** – Cruise-O-Matic transmission

**COMPOSITE BRAKE DRUM** – cast metal inside with steel outside

**CONCOURS** – Refers to judged car show where the car is judged as it would be seen new or as stock

**CORE** – A core is the part you return in exchange for a new part. Core fees are in addition to the price of the new item. The core must be complete and rebuildable to receive full core credit. Parts missing from the core will be deducted from the core fee.

**COUPE** – has no post at the door opening

**COWL** – area between the hood and windshield

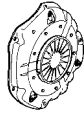

**DIAPHRAGM STYLE** – Type of clutch cover that uses a shallow, cone-shaped spring disc to provide pressure to the plate

**DISTRIBUTION BLOCK** – At the master cylinder; brake lines are sent out to all four wheels

**DURA SPARK** – electronic solid-state ignition

**EEC** – engine electronic control

**EFI** – electronic fuel injection

**EGR** – exhaust gas recirculation

**EM/RE** – emission reduction

**EMS** – emissions

**ESCUTCHEON** – A plate (example: the cover behind a door handle)

**EV/EM** – evaporative emission

**F/B** – Fastback; roof line slopes back, usually has a large back glass

**FE** – an engine series

**FINNED BRAKE DRUM** – cast metal piece with fins

**F/M/2** – Ford-O-Matic 2-speed transmission

**FORMAL ROOF** – same as a hardtop

**FROM SERIAL #** – refers to the number on the data plate after which a change was made in production

**GPD** – Genuine Parts Distributors

**GT** – grand touring

**GVW** – gross vehicle weight

**H/D** – heavy duty

**HDC** – heavy duty cooling

**HEADER** – The body panel in front of hood, if applicable. The front leading edge of a convertible top

**HI-PO** – high performance

**I.D.** – inside diameter

**IMCO** – improved combustion

**INSULATOR** – Rubber or vinyl, as in engine insulator or motor mount

**I/P** – integral power steering

**KR** – king of the road

**LANDAU** – Back half of the roof that is covered with vinyl



**LEVER STYLE** – Type of clutch cover that uses coil springs to provide pressure to the plate

**LH** – left hand (driver's side)

**MCA** – Mustang Club of America

**MOTORCRAFT** – Ford's present day service division

**MOULDINGS** – NOT weatherstrip. Metal or plastic trim

**M/S** – manual steering

**M/T** – manual transmission

**N.O.S.** – new old stock

**N.O.R.S.** – new old reproduction stock

**O.D.** – outside diameter

**OE or OEM** – original equipment or original equipment manufacturer

**OFFSET / BACKSPACING** – Distance from the wheel mount to the outside rim

**P/C** – police car

**PCV** – positive crankcase ventilation

**PHB-AC** – transmission tag code (example)

**PI** – police interceptor

**PILLAR POST** – the pillar at the front windshield

**PLENUM CHAMBER** – Directs heated air to the defroster or passenger compartment

**P/S** – power steering

**QUARTER** – rear fender

**QUARTER PILLAR** – the pillar at the front of the rear quarter or at the rear of the door opening

**RH** – right hand (passenger's side)

**ROTUNDA** – Ford's service division in the '60s

**S/C** – standard cooling

**S/CJ** – Super Cobra Jet

**S/D** – sedan delivery

**SFI** – organization that issues and administers standards for specialty/performance automotive and racing equipment

**S.M.CO.** – Specialty Motor Company

**SPREAD BORE** – A type of carburetor that has a small primary venturi and a larger secondary venturi that provides fuel efficiency and greater acceleration

**S/T** – standard transmission

**STD** – standard

**S/W** – station wagon

**T/E** – Thermactor emission

**TO SERIAL #** – refers to the number on the data plate before which a change was made in production

**UPHOLSTERY** – NOT the complete seats; refers to the outer covers only

**V/V** – variable venturi

**W/4/S** – Warner 4-Speed

**WINDLACE** – vinyl or cloth trim at the door openings

**W/S** – windshield

**X/C** – extra cooling

# !! WANTED !!

## PHOTOS OF YOUR MAVERICKS & COMETS



*Here is a way to get some money back  
from your restored Classic Ford or Mercury!*

We need color pictures of our customers' cars and trucks  
for inclusion in our catalogs, promotional items, and our website.

**Here's what's in it for YOU!**  
a **\$25.00** gift certificate\*  
for EACH photo we use on a cover  
\*to be used for a future purchase with us

### \*\*\* What We Need From You \*\*\*

- Clear, color photos with good contrast, lighting, and pleasing backgrounds.
- Watch those shadows and light spots that wash out the color of the vehicle! Overcast days are usually best for shooting outdoors.
- Choose a location away from objects that may reflect in the vehicle's finish.
- No individuals or animals should be in the photo.
- Stock or near-stock vehicles are preferred over heavily modified ones.
- Three-point (an angle with three sides of the vehicle visible) shots are preferred. Take a look at our covers for examples.
- High-quality photos taken with a digital camera only, please; smartphone photos are not encouraged.
- Please include vehicle info and contact info with all image file submissions, either on the disc (if shipped) or in the accompanying email (if sent electronically).
- If submitting prints, please use a glossy photo finish (not plain paper) and put vehicle info and owner contact info on the back of **each** photograph. Labels are preferred. If you do not have a label, leave the back blank.
- While we encourage amateur photographers to submit, photos shot by professional photographers must be accompanied by any signed release form required by the photographer. If no release is required, please state this in your submission.



Any questions? Please call us toll-free at 1-800-228-7346 and ask for Catalog Production, or send us an inquiry via our website: [www.AutoKrafters.com](http://www.AutoKrafters.com).

Send photos and descriptive information of the vehicle (year, make, model, etc.) and some info about the owner to:

**Auto Krafters, Inc., Attn: Catalog Production, 129 Hartz Blvd. Dept. PH, Broadway, VA 22815**

PLEASE REMEMBER: Submitting a photo does not guarantee it will appear on a catalog cover. All cover photo submissions must go through a process of evaluation and approval before they are considered for a cover. Due to the length of time between catalog releases, it may be months between your submission and finding out whether your photo made the cut. All photos submitted become property of Auto Krafters, Inc. and will be kept on file unless the person submitting them requests that they be returned AND has included a self-addressed, stamped envelope for their return. Auto Krafters, Inc. is not responsible for photos lost in the mail. Photos we use, and issue credit for, will permanently become property of Auto Krafters, Inc. and will not be returned. \$25.00 credit memo will be issued ONLY if the photo is used on a catalog cover; no credit will be issued for simply submitting a photo. While we anticipate this program going on indefinitely, we do reserve the right to cancel this offer at any time without prior notice.

**Show Us What You've Got!**

Since 1978  
**AUTO  
KRAFTERS**

**PLEASE PRINT!!!**

NAME: \_\_\_\_\_

Address: \_\_\_\_\_

City: \_\_\_\_\_ State/Prov: \_\_\_\_\_ Country: \_\_\_\_\_

Zip Code/Postal: \_\_\_\_\_ Phone: \_\_\_\_\_ E-mail: \_\_\_\_\_

**Type of car owned:**

Year: \_\_\_\_\_ Make: \_\_\_\_\_ Model: \_\_\_\_\_ / (GT or Grabber) (Circle One)  
2 door or 4 door

**Factory Equipment:**

Engine: \_\_\_\_\_ Trans: \_\_\_\_\_ Floor or Column Shift: \_\_\_\_\_

Color: \_\_\_\_\_ Interior Color: \_\_\_\_\_ Bucket / Bench Seats \_\_\_\_\_

Other Options(list): \_\_\_\_\_

Serial Number: \_\_\_\_\_

Codes: (From Vehicle ID Sticker, Body Buck Tag, Build Sheet, etc.)

Body: \_\_\_\_\_ Color: \_\_\_\_\_ Trim: \_\_\_\_\_ Axle: \_\_\_\_\_ Trans: \_\_\_\_\_ DSO: \_\_\_\_\_

**Do you own more than one Maverick / Comet?:** \_\_\_\_\_ (Please attach separate sheet for each one.)

**Other Information:**

Please send me my newsletter by (Circle One ONLY): \_\_\_\_\_ Email \_\_\_\_\_ Post Office \_\_\_\_\_

Do you wish to be considered for state/province representative? \_\_\_\_\_

How far would you be willing to travel to attend a National Meet? \_\_\_\_\_

**Membership Payment Options:**

You have the choice of email or post office newsletter:

1. Joining for the entire current **calendar** year. No matter when you join in the current calendar year, you will be sent all current year back issues of the newsletter, plus the balance of this year's newsletters: **Email Newsletter = \$10.00**

**Post Office Newsletter = \$20.00**

**Post Office Outside the USA = \$30.00**

2. Joining during the current **calendar** year and submitting payment based on the schedule below. You will not receive any back issues, only the balance of the remaining newsletters for this **calendar** year:

**Check one that applies below:**

Join in April or May of current calendar year and receive 5 newsletters: Post Office=\$17.00 Outside the USA=\$25.00

Join in June or July of current calendar year and receive 4 newsletters: Post Office= \$14.00 Outside the USA=\$20.00

Join in August or September of current calendar year and receive 3 newsletters: Post Office=\$11.00 Outside the USA=\$15.00

Join in October or November of current calendar year and receive 2 newsletters: Post Office=\$7.00 Outside the USA=\$10.00

Join in December and your membership will be applied toward next calendar year: Pay FULL YEAR amount from Payment Option #1

**All EMAIL members pay \$10.00 no matter what time of year, newsletter back issues will be emailed.**

**WITH THE ENCLOSED PAYMENT, I AGREE TO JOIN THE MAVERICK /COMET CLUB INTERNATIONAL, INC. I ALSO UNDERSTAND THAT MY NAME, ADDRESS, AND PHONE NUMBER MAY BE PRINTED IN THE NEWSLETTER OR RELEASED WITHOUT NOTICE AS DEEMED ACCEPTABLE BY THE CLUB OFFICERS IN RELATION TO CLUB BUSINESS.**

**Signed:** \_\_\_\_\_ **Date:** \_\_\_\_\_

Please enclose check or money order payable to: MAVERICK / COMET CLUB INTERNATIONAL, INC.

Club Membership.....(write in amount from above) \_\_\_\_\_

Additional Window Decals.....\$1.00 each \_\_\_\_\_

**TOTAL AMOUNT ENCLOSED (U.S. DOLLARS) \$** \_\_\_\_\_

Below for MCCI Use ONLY!!!

\_\_\_\_\_ Add \_\_\_\_\_ Check # \_\_\_\_\_ MO \$\$\$ \_\_\_\_\_ PD



Please do not send membership application or dues to Auto Krafters, Inc.





**10%  
Discount**

**\$14.95  
Flat  
Shipping**



# **AUTO KRAFTERS, INC. GOLD CARD CLUB**

*For the Classic Ford Enthusiast*

See details on back

----- DETACH FORM HERE -----

1 year membership – \$49.95       2 year membership – \$79.95

Name: \_\_\_\_\_

Address: \_\_\_\_\_

City: \_\_\_\_\_ State: \_\_\_\_\_ Zip: \_\_\_\_\_

Daytime Phone Number: \_\_\_\_\_ Fax Number: \_\_\_\_\_

Evening Phone Number: \_\_\_\_\_

Email: \_\_\_\_\_

Year and Type of Vehicle: \_\_\_\_\_

Please charge my credit card     \$49.95 for one year     \$79.95 for two years

Specify:     VISA     MasterCard     Discover     Am Ex

Credit Card #: \_\_\_\_\_ Expiration Date: \_\_\_\_\_

Print name on card: \_\_\_\_\_

Signature of card holder: \_\_\_\_\_

I am enclosing:     \$49.95 for one year     \$79.95 for two years  
                           Cash                                    Check                                    Money Order

Please enclose payment and mail to: **Auto Krafters, Inc.  
129 Hartz Blvd.  
Broadway, VA 22815-0008**

Your membership card will be sent to you in the mail. Satisfaction guaranteed. If you feel this program is not for you, simply notify us in writing within 60 days. We will refund your membership fee minus any discounts already given.

**Auto Krafters** is your source for classic Ford parts and accessories. Since 1978, we have helped Ford enthusiasts across the world maintain their vehicles – from show cars to favorite drivers. We are proud to offer you the opportunity to become a member of the Auto Krafters Gold Card Club – an exclusive club that offers the privileges you deserve!

For only \$49.95 per year (\$79.95 for two years) you will receive such benefits as:

- \$14.95 flat shipping fee on all orders. Some exceptions apply. (See **Note 1**)
- Priority Order Handling; shipped the same day on in-stock items for orders placed before 1 p.m. ET.
- 10% discount on Internet, phone and fax orders over \$100 (excluding shipping). Must have part number(s) ready before placing phone or fax orders. Special shipping rates may apply. (See **Note 1**)
- Liberal return policy on items in sellable condition. (See **Note 2**)
- Price match guarantee on any currently advertised competitors prices. (See **Note 3**)
- Program is available for continental USA shipments only.



## Membership Rules

- You must have your Gold Card Club membership number on your order form or available when you call to receive membership benefits. If your number is not present, you will not receive the benefits. No retroactive benefits to orders placed before becoming a member.
- You will be notified of any price changes on items. Balances due must be paid before shipment is made. Please make sure you give us a daytime phone number and / or email address for immediate notification.
- Back-ordered items or drop shipments are not subject to priority handling.
- **Discounts not available on:** weatherstrip kits; fiberglass parts; rebuilds and core fees; rechromed bumpers; batteries; wheels; disc brake conversion kits; suspension kits; leaf springs; replacement glass; N.O.S. parts; A/C kits; wiring harness upgrade kits; certain early '60s dash pads ('60-'64 Galaxie, '60-'63 Falcon, '61-'66 pickup); '66-'67 Fairlane quarter panels; AMD products; Performance Auto Exhaust exhaust system and H-pipes; or online purchases of carpet, floor mats and / or trunk mats.
- Discounts apply to classic Ford parts only (1979 and earlier).
- Free shipping not available outside the continental US.
- Auto Krafters reserves the right to choose the best shipping method.

**Note 1:** Excludes shipping on weatherstrip kits, batteries, A/C kits, wheels, disc brake conversion kits, suspension kits, leaf springs, replacement glass, oversized UPS orders, and truck shipments. Free shipping not available outside the continental US.

**Note 2:** Items are nonreturnable after installation. Sellable condition means that the item can be put back into stock for immediate resale. Electrical items are not returnable. Defective items will be replaced under warranty.

**Note 3:** Must be an equivalent quality part to receive matching price.

Auto Krafters reserves the right to modify this program without prior notice.

Need a current catalog? Sign up for membership in the Auto Krafters Gold Card Club and choose up to two of the catalogs below. We will send them to you via Priority Mail at no charge.



- |  |   |
|--|---|
| <input type="checkbox"/> '70-'77 Maverick / '71-'77 Comet  | <input type="checkbox"/> '62-'70 Fairlane / '68-'76 Torino;<br><i>Also includes '66-'69 Comet,<br/>'68-'71 Montego / Cyclone,<br/>'62-'63 Meteor and '67-'79 Ranchero</i> |
| <input type="checkbox"/> '60-'70½ Falcon / '60-'65 Comet;<br><i>Also includes '60-'66 Ranchero</i> | <input type="checkbox"/> '60-'70 Galaxie and other<br><i>full-size Fords and Mercurys</i>   |
| <input type="checkbox"/> '67-'73 Cougar  |   |
| <input type="checkbox"/> '71-'80 Pinto / '75-'80 Bobcat  |   |
| <input type="checkbox"/> '61-'79 F-Series Pickup   |   |

129 Hartz Blvd. • Broadway, VA 22815-0008  
(540) 896-5910 • FAX (540) 901-2908  
[www.autokrafters.com](http://www.autokrafters.com)

**AUTO  
KRAFTERS** 





# AUTO KRAFTERS<sup>INC</sup>

129 Hartz Blvd. • Broadway, VA 22815

Issue 2021

Phone (540) 896-5910 • Fax Number (540) 901-2908 • [www.autokrafters.com](http://www.autokrafters.com)

Mailing / Billing Address	Shipping Address
Name _____	Name _____
Address _____	Address _____
City _____ State _____	City _____ State _____
Zip _____ Daytime Phone ( ) _____	Zip _____ Daytime Phone ( ) _____

**NOTE:** Please give a street address for shipping. UPS and truck lines will not deliver to a PO Box.

Customer # \_\_\_\_\_ Gold Card Club Membership # \_\_\_\_\_ E-mail \_\_\_\_\_

<b>Vehicle Info</b> Please check all that apply	<input type="checkbox"/> Maverick	<input type="checkbox"/> 2-door	<input type="checkbox"/> 4-door	<input type="checkbox"/> Vinyl top	<input type="checkbox"/> Grabber	<input type="checkbox"/> Sprint	<input type="checkbox"/> Stallion
	<input type="checkbox"/> Comet	<input type="checkbox"/> 2-door	<input type="checkbox"/> 4-door	<input type="checkbox"/> Vinyl top	<input type="checkbox"/> GT	Interior Code: _____	
	Year: _____	Body Style: _____	Engine: _____	Transmission: _____	Interior Color: _____		

Page No.	Year of Vehicle	Qty.	Part Number	Description	Unit Price	Total Price of Items

Shipping and Handling Fee Chart	Sub Total																								
These are standard UPS or FedEx Ground shipping amounts for the continental USA only. Shipping quotes will be given for all air shipments and truck freight shipments upon request from the customer.	Add Shipping and Handling																								
<table border="1"> <thead> <tr> <th>Order Total</th> <th>Standard 7 to 10 Days</th> <th>Order Total</th> <th>Standard 7 to 10 Days</th> </tr> </thead> <tbody> <tr> <td>\$0.00-\$49.99</td> <td>\$14.95</td> <td>\$350.00-\$499.99</td> <td>\$39.45</td> </tr> <tr> <td>\$50.00-\$99.99</td> <td>\$18.95</td> <td>\$500.00-\$599.99</td> <td>\$44.45</td> </tr> <tr> <td>\$100.00-\$149.99</td> <td>\$24.95</td> <td>\$600.00-\$699.99</td> <td>\$49.45</td> </tr> <tr> <td>\$150.00-\$249.99</td> <td>\$29.45</td> <td>\$700.00-Up</td> <td>\$54.45*</td> </tr> <tr> <td>\$250.00-\$349.99</td> <td>\$34.45</td> <td></td> <td></td> </tr> </tbody> </table>	Order Total	Standard 7 to 10 Days	Order Total	Standard 7 to 10 Days	\$0.00-\$49.99	\$14.95	\$350.00-\$499.99	\$39.45	\$50.00-\$99.99	\$18.95	\$500.00-\$599.99	\$44.45	\$100.00-\$149.99	\$24.95	\$600.00-\$699.99	\$49.45	\$150.00-\$249.99	\$29.45	\$700.00-Up	\$54.45*	\$250.00-\$349.99	\$34.45			Add Boxing Fee <i>For Dash Pads &amp; Covers, Package Trays, Hoods, Fenders, Quarter Panels, Floor Pans, Radiators, Gas Tanks, etc.</i>
Order Total	Standard 7 to 10 Days	Order Total	Standard 7 to 10 Days																						
\$0.00-\$49.99	\$14.95	\$350.00-\$499.99	\$39.45																						
\$50.00-\$99.99	\$18.95	\$500.00-\$599.99	\$44.45																						
\$100.00-\$149.99	\$24.95	\$600.00-\$699.99	\$49.45																						
\$150.00-\$249.99	\$29.45	\$700.00-Up	\$54.45*																						
\$250.00-\$349.99	\$34.45																								
A \$1.50 insurance fee has been added to all orders over \$150.00	Add \$5.00 Rush Special Handling Fee <i>Gives you priority over all other guaranteed orders. If we receive the order by 2:00 p.m. Eastern Time and it is in stock, it will be shipped out the same day.</i>																								
* Except for oversized and overweight items.	Add Va. 5.3% Sales Tax (Va. Sales Only)																								
	<b>Total</b>																								

**Check Method of Payment:**

Money Order or Cashier's check       Personal or Company Check (Order held 7 days for bank clearance.)

---

Credit Card (Specify):

**Minimum Order Amount on Credit Card is \$20.00**

<input type="checkbox"/> VISA <input type="checkbox"/> MasterCard	Expiration	Credit Card Number
<input type="checkbox"/> Am Ex <input type="checkbox"/> Discover	____/____	_____
		CCV #**
		_____

\*\*4 digits on front of card (Am Ex) or 3 digits on back (all others).

\_\_\_\_\_  
Signature of Cardholder

\_\_\_\_\_  
Print Name on Card

# ORDERING INFORMATION

## Order by Phone

It's fast and convenient! For best service have all catalog and credit card information ready, then call:

**TOLL-FREE ORDER LINE 1-800-228-7346\***  
**FAX NUMBER 1-540-901-2908**  
**LOCAL NUMBER 1-540-896-5910**

A \$20 MINIMUM IS REQUIRED FOR ORDERS PLACED OVER THE PHONE. Mastercard, VISA, Discover and American Express are welcome. C.O.D. shipments are not available for any items.

## Mail Orders

Fill out the order blank in the back of this catalog. For fastest delivery, send a money order or cashiers check. **Personal checks are accepted but will delay the order 7 days while the check clears the bank.** Mastercard, VISA, Discover and American Express are welcome. A \$20 MINIMUM IS REQUIRED FOR ORDERS PLACED THROUGH THE MAIL. Be sure to include card number, expiration date, billing address, and signature of cardholder.

## Fax Orders

Accepted 24 hours daily. Mastercard, VISA, Discover and American Express. A \$20.00 MINIMUM IS REQUIRED FOR ORDERS PLACED OVER THE FAX. Fax number is 540-901-2908.

## Warranty / Exchanges

All parts are guaranteed. **Please inspect the shipment as soon as you receive it.** If you have a problem with any purchase, please call one of our associates at 800-228-7346\*. Many times, application problems can be quickly handled by phone, saving needless shipping expense. Should you find it necessary to return anything, a copy of our return procedures is packed with your invoice. **All claims for shortages must be made within 48 hours. No shortage claims will be accepted after 48 hours. To better facilitate our handling of returned items, please call and obtain a return authorization number. All returns must be sent prepaid. C.O.D. returns will be refused. Returns older than 30 days are subject to a restock fee. Absolutely no returns after 120 days from date of purchase regardless of reason unless covered by an extended warranty.** We reserve the right to charge a restocking fee on certain items. Special orders are also subject to a restock fee. Auto Krafters, Inc.'s liability is limited to the replacement of the product or refund of the purchase price. Installation labor costs or shipping charges are not refunded. Electrical parts are non-returnable once installed. We will replace defective units only. **Our associates are available from 9:00-5:00 Monday-Friday ET.**

## Warehouse Location

Auto Krafters, Inc.'s office and warehouse are located in Broadway, Va., off Interstate 81 exit 257. 129 Hartz Blvd. • Broadway, VA 22815. Our local phone number is 540-896-5910. **Sorry no personal checks accepted for showroom purchases without prior authorization.**

## Store Hours (Eastern time zone)

MONDAY-FRIDAY ..... 9:00 AM-5:00 PM  
SATURDAY ..... 9:00 AM-NOON  
SUNDAY ..... CLOSED

## Phone Hours (Eastern time zone)

MONDAY-FRIDAY ..... 9:00 AM-5:00 PM  
SATURDAY ..... 9:00 AM-NOON  
SUNDAY ..... CLOSED

## Shipping Charges

In the continental United States, there is a **minimum shipping charge of \$14.95.** Most orders are shipped via UPS or FedEx. Please furnish a complete street address as UPS cannot deliver to a post office box number. **We reserve the right to ship extra heavy or oversize shipments freight collect.** Hoods, fenders and quarter panels fall in this category. If you have prepaid the shipping and the order has to be shipped freight collect, we will refund your prepaid shipping. If you have any question, please call us at 800-228-7346\* for assistance. **Please check all truck shipments for damage before signing the bill of lading. Once truck shipments are signed for, no claims can be made for damage.** Some parts require additional handling charges. Fragile items, such as mouldings, will be shipped in PVC tubes and will incur a \$15 handling fee. All oversized items will incur a \$10 boxing fee and / or crate charges where applicable. Please inquire about additional handling charges when ordering.

Alaska, Hawaii, Puerto Rico and Canadian orders should add 20% estimated shipping and handling with a minimum of \$20.00. Other foreign countries should add 35% with a minimum of \$20.00. Any excess will be refunded. Canadian customers are responsible for all customs brokerage fees and duties.

## Customer Satisfaction

Our goal is customer satisfaction and we strive to sell the highest quality parts at competitive prices. If you encounter a problem with your order, contact us immediately so that we may resolve the problem. We want your repeat business and the business of your friends and neighbors. Most orders are processed and shipped within 24 hours of receipt. If we should need to back order any items, they will be shipped as soon as possible unless you notify us otherwise. If you require your parts delivered by a specific date, please advise us when placing your order and we will do our best to accommodate your needs.

## Back Ordered Items

Due to the difficulty of keeping some items in stock, an item you order may be put on back order for later delivery. Most back ordered items can be shipped in 21 days. If you do not receive your back ordered items within the time stated on your notification letter, please call us at 1-800-228-7346\* for a revised delivery date.

## Origin of Parts

We sell both Genuine Ford and quality reproduction parts acquired from many sources, both domestic and foreign. We will be happy to give you the country of origin of all our parts, if known. All Ford Trademark parts sold (such as emblems, etc.) are licensed by Ford Motor Company®. **The majority of the parts in this catalog are made in the USA, are reproductions of originals and are NOT Genuine Ford.** Auto Krafters is proud to offer reproduction parts and accessories from such manufacturers as Dennis Carpenter®, Auto Custom Carpet®, Jim Osborn Reproductions®, Drake Automotive Group® and many others.

**NOTE:** We are not responsible for typographical errors. Prices are subject to change without notification.

**NOTE:** Illustrations are typical and may not be representative of the part you are ordering.

Secure online ordering @ our web site  
<http://www.autokrafters.com>

**Auto Krafters, Inc.**  
**129 Hartz Blvd.**  
**Broadway, VA 22815**

\* US customers only. Outside the US, please dial 540-896-5910

Copyright © 2021 Auto Krafters, Inc. All rights reserved. Printed in the United States of America. No part of this publication may be reproduced including drawings, photographs or text without the prior written permission of Auto Krafters, Inc. All statements and recommendations contained herein are based on information we believe to be reliable, but the accuracy thereof is not guaranteed.

# CLASSIC FORD PARTS AND ACCESSORIES

Auto Krafters, Inc. has all the parts  
at af**FORD**able prices!

## THREE WAYS TO ORDER!



### MAIL

Just fill out the order form in this catalog and send it in.



### PHONE

Call toll-free and our associates can help you with your order. Faster than mail.



### ONLINE

Fast, secure shopping 24 hours a day, 7 days a week!  
[www.autokrafters.com](http://www.autokrafters.com)

or



check us out on eBay!  
seller IDs: akraft and fordcloseoutdeals

**FREE**  
catalogs in the continental US!  
Specify year and make



'62-70 Fairlane  
'68-76 Torino  
'67-79 Ranchero



'60-70 1/2 Falcon  
'60-65 Comet  
'60-66 Ranchero



'60-70 Galaxie and other full-size Fords and Mercurys



'70-77 Maverick  
'71-77 Comet

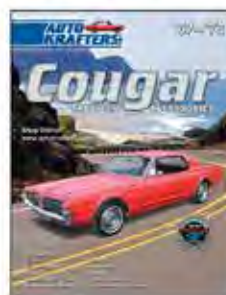

'67-73 Cougar

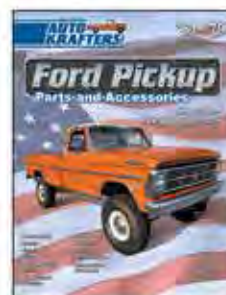

'61-79 F-Series Pickup

Auto Krafters, Inc. stocks a full line of CLASSIC FORD Weatherstrip at DISCOUNT PRICES.

We specialize in Rebuilt Power Steering Components and Steering Gear Boxes. Please call us for pricing.



AVAILABLE ON CD-ROM!  
ALL Auto Krafters catalogs in PDF!



'71-80 Pinto  
'75-80 Bobcat



Toll-free ordering, by phone or online  
Visa / MC / AmEx orders  
(Ask for shipping charges)

**1-800-228-7346**  
[www.autokrafters.com](http://www.autokrafters.com)

129 Hartz Blvd.  
Broadway, VA 22815  
Fax (540) 901-2908

Since 1978  
**AUTO KRAFTERS!**



## Reproduction Bumpers!

- Front and Rear
- Triple-Chrome Plated
- Durable, Long-Lasting Finish

No more trying to re-plate old, worn bumpers. Replace those dented, rusted bumpers with quality reproductions from Auto Krafters!

For more information, see page 35.



**NEW!**



And while you're at it, check out our reproduction bumper mounting brackets, also on page 35.

## Exterior Trim!



**NEW!**

MAVERICK

- Grille Ornament
- Grille / Trunk Emblem
- Hood Moulding

Excellent reproductions

For more information, see pages 32-33.

## High Quality Interior Trim!

### Retro Seat Belts

With or Without Shoulder Belts – Retractable and Non-Retractable  
"Aviation"-Style or Square Buckle

Vintage Styling

Meets or exceeds Federal Motor Vehicle Safety Standards

Available in a wide variety of colors.

For more information, see pages 6-7.



### Carpeted Floor Covering



Quality Floor Covering from  
the Leader in Automotive Carpet  
Carpet or Vinyl  
Cut Pile or Loop

We offer high-quality molded floor covering for your classic Maverick or Comet in a wide range of colors.

See page 11 for details.



Also see our selection of  
Maverick and Comet logo  
floor mats, also on page 11.

MAVERICK



Comet

### Loop Pile Carpet Colors

				
Black	Blue	Red	Maroon	Dark Blue
				
Light Saddle	Dark Saddle	Dark Brown	Ivy Gold	Dark Green
				
Moss Green	Aqua	Gunmetal Gray	Charcoal Gray	

Cut Pile Carpet Also Available in Many of the Same Colors